

Extensive and Semi-Intensive Culture of Prawn and Shrimp in the Philippines

Florentino D. Apud

Aquaculture Department, Southeast Asian Fisheries Development Center
P.O. Box 256, Iloilo City, Philippines

Abstract Various farming systems for prawn and shrimp are compared, with emphasis on the extensive and semi-intensive culture of tiger prawn *Penaeus monodon* and white shrimp *Penaeus indicus* in monoculture or in polyculture with milkfish (*Chanos chanos*). The bases of comparison include pond design characteristics, stocking density, food supply, water management, average production, technical, and other major input requirements. Common factors that may influence production for each system are also discussed.

It is observed that prawn and shrimp production has been mainly characterized by the extensive system. Of the 200,000 ha of brackishwater fishponds in the Philippines, about 25% (50,000 ha) are stocked with prawns and shrimps in monoculture or in polyculture with milkfish. Only a relatively small portion (less than 500 ha) of the area is utilized for semi-intensive culture. The dramatic increase in area utilization for extensive prawn production in recent years can be attributed to high market demand, increased hatchery-bred fry production, minimum technical requirements, and lower production cost and risks.

The trend towards intensification among existing large fishfarms is hampered by rising capital costs for fishpond improvement and increasing operational expense and risks. However, intensification is gaining some attention and progress in limited areas, primarily to maximize utilization and production to avoid high investment cost of land for expansion. Further development and progress in the industry will be dependent on such factors as market price, availability of fry and feed at reasonable cost, supply of trained technicians, technical problems, financial situation, and economic viability of the operation.

Introduction

Prawns and shrimps* are among the food items with high demand in Japan, U.S.A. and some European countries. Tan (1984) reported that Japan's imports of frozen prawn and shrimp in 1983 was 148,589 tons. The Philippine export of the same product for that year was only 4,321 tons or barely 2.9% of Japan's total imports.

U.S. consumption of tropical shrimp in 1983 was 216,400 tons, of which 155,180 tons were imported. In effect, the total market demand for frozen prawn and shrimp in U.S.A. and Japan alone is about 300,000 tons annually excluding the demand of Europe and other countries.

The potential for prawn and shrimp production in the Philippines has been very promising. The country has a warm tropical climate, ideal soil for culture, and unpolluted estuarine areas considered to be the natural habitats of these species. Also, a good portion of the vast existing brackish-water fishponds presently devoted to milkfish culture is suitable to the culture of various penaeid prawns and shrimps. Among the commercially important species now being cultured in the Philippines are the jumbo tiger prawn, *Penaeus monodon*; white shrimp, *P. indicus* and *P. merguensis*; and the sand shrimp, *Metapenaeus ensis*.

*Prawns and shrimps in this paper refer to the jumbo tiger prawn *Penaeus monodon* and the white shrimps *P. indicus* and *P. merguensis*, respectively.

Highlights of development

Prawn and shrimp farming in the Philippines has evolved from a traditional and crude polyculture method to an improved monoculture farming system. In earlier decades, farmers were largely dependent on the entry of wild fry into their ponds during spring tide. The fry brought inside the pond by tidal inflow were grown on natural food often together with milkfish. Since the occurrence of fry is seasonal and the quantity unpredictable, the production of prawn and shrimp during this period was unreliable.

To be assured of better production, farmers thought of intentionally stocking a certain number of fry in monoculture or polyculture with milkfish. Wild prawn and shrimp fry were then collected using various gears such as lures made of grass and twigs, filter net and fry raft, fry seine and scissors net depending on whether the collecting site is along the shore, mouths of rivers or estuaries, etc. (Motoh, 1981). Since information on pond culture of prawn was inadequate at the time, farming attempts often failed.

The increasing demand for prawn and shrimp in the international market in the early sixties triggered the interest of both the government and private sectors in developing the prawn industry. Upon gaining some information from printed materials and from fishery scientists and officials who have observed prawn culture activities in Taiwan and Japan, some farmers ventured seriously into prawn production. Most if not all ventures, however, did not prosper due to various problems such as inadequate and seasonal fry supply, lack of technical knowhow and skill, and the high rate of

mortality in ponds (Delmendo and Rabanal, 1956; Caces-Borja and Rasalan, 1968).

Breakthroughs in the mass production of penaeid fry under controlled conditions at the Mindanao State University Institute of Fisheries Research and Development, in Nawan, Misamis Oriental and SEAFDEC Aquaculture Department in Iloilo, in the late sixties and early seventies marked the take-off point in the development of the prawn and shrimp industry in the Philippines. The impact on industry was the venturing into prawn culture of more farmers because of greater assurance of fry supply.

With the proliferation of hatcheries all over the country in the late seventies and the development of nursery techniques (Apud, 1979), more fishponds were converted to, or constructed for, prawn culture. A privately-owned multimillion peso prawn culture complex was in fact established in Negros Occidental in 1979. A number of entrepreneurs followed and established different types of prawn culture facilities whose sizes varied according to level of investment.

In 1983, there were about 60 government and privately-owned hatcheries in the country with an estimated total pro-

duction potential of 500 million fry annually (Primavera, 1984). This quantity can supply about 50,000 ha at a stocking density of 5,000/ha at two croppings/year. Even if only 40% (200 million fry) of estimated potential capacity is achieved, the hatcheries are still capable of supplying some 20,000 ha.

The rapid increase in fry supply as a result of continuous progress in hatchery operations has greatly increased the hectareage for prawn production during the last five years. To date, it is estimated that about 30,000 to 50,000 ha of the 200,000 ha of brackishwater ponds in the Philippines are devoted to prawn production utilizing various culture systems.

Classification of culture systems

Prawn and shrimp culture systems are classified into three, namely, extensive, semi-intensive, and intensive. The classification is based mainly on pond facilities, stocking density, food supply, water management, yield, technical knowhow and skill and other major inputs. While semi-intensive and intensive farming have gained some progress in recent years, the extensive system still remains the major practice possibly because of the relatively large landholdings (50-300 ha) per farmer. In order to shift to the semi-intensive or intensive system, large areas will require greater amount of inputs, risk, high-level technical knowhow, and supervision.

On the other hand, increasing acquisition and development costs per unit area has led farmers with small landholdings to go into intensive operation. Intensified farming virtually increases the yield per hectare thereby absorbing the relatively higher capital investment and risk. Further progress and development of any farming operation will largely depend on the supply and cost of fry, technical knowhow, quality and cost of feed, and economic viability of the operation. For purposes of this paper, discussion is confined to extensive and semi-intensive farming operations.

Basic considerations

Site suitability

The major environmental factors that influence prawn and shrimp production in extensive and semi-intensive operations include climatic conditions, source of water, and type of soil. Better production is observed in areas having short and not so pronounced dry season with moderate rainfall distributed almost throughout the year and having sufficient source of good water free from pollutants, with salinity of 10-20 ppt and pH above 7. Desirable types of soil for diking purposes are either clay loam, silty clay or silt loam. Sandy clay suits the creeping and burrowing habit of *P. monodon*. The favorable soil pH is between 7.0 to 8.3. It is desirable to have pond bottom elevation easily reached by ordinary high tides to enhance water replenishment and to easily maintain desirable water depth of 1 m. Accessibility of areas also facilitates supervision and transport of input materials and products. Support facilities such as electricity and an ice plant, if available, are beneficial.

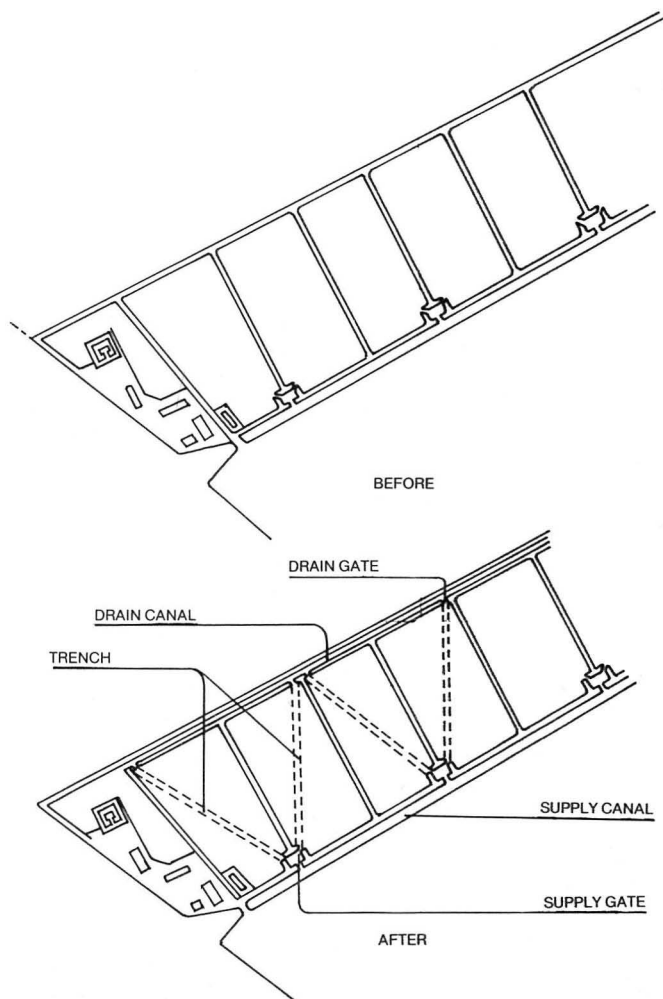

Fig. 1. Milkfish ponds renovated into semi-intensive prawn culture ponds at the Leganes Research Station, SEAFDEC Aquaculture Department (after Torres, 1983).

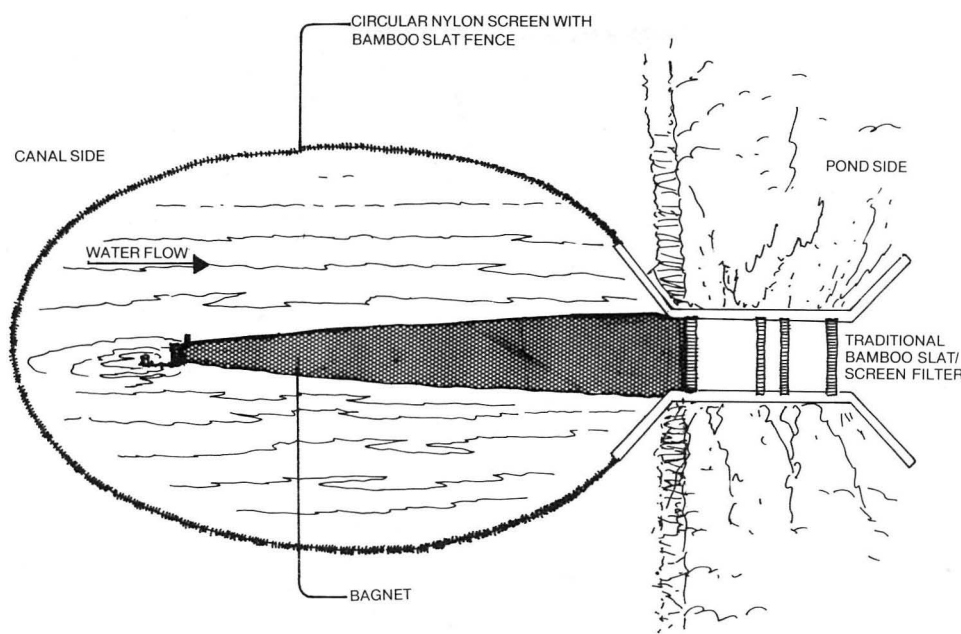

Fig. 2. Combined use of circular screen and bagnet to effectively control pests and predators.

Pond design characteristics

At present, most prawn farmers utilize ponds originally designed for milkfish culture. In extensive farming where prawn and shrimp are mainly dependent on natural food, minimal improvements are introduced depending on the existing conditions of the milkfish pond. In contrast, more improvements in terms of depth, gate and canal system are required for semi-intensive operations.

In extensive ponds, existing compartments range from 2 to 20 ha. Such large sizes lead to difficulties in water management, pest and predator control, and retrieval during harvest. Hence, pond sizes ranging from 1 to 5 ha are more appropriate for the extensive system. In semi-intensive ponds where the stock is provided with supplementary feeds in addition to natural food, more efficient water exchange is needed. Smaller pond areas ranging from 1 to 2 ha are ideal.

Ponds capable of holding water at least 80 cm deep are desirable for both extensive and semi-intensive operations. If this is not met, the yield is affected. Otherwise a bottom trench, 5-10 m wide and 0.5 m deep, is excavated along the dikes or across the pond to provide a deeper portion covering at least 25% of the total area. Both extensive and semi-intensive ponds require dikes that are structurally strong and high enough to provide free board of at least 30-40 cm for division dikes and 50-60 cm for secondary dikes.

A single gate and canal system to serve both water supply and drain requirements is adequate for ponds of not more than 3 ha in extensive operations. However, the single gate-canal system is inadequate for larger ponds. In semi-intensive ponds, supply gate and canal system is separate from the drain gate and canal (Fig. 1) to allow more efficient water exchange and to operate on a flow-through basis. The traditional screening facilities (bamboo screen) used for milkfish culture are not applicable. These are replaced by fine-mesh

screen (0.2 mm mesh) installed singly either as bagnet or as a circular screen or a combination of both (Fig. 2).

Extensive and semi-intensive culture operations

Pond preparation

Pond preparation in the extensive and semi-intensive culture systems includes the following activities: drying of pond bottom, eradication of pests and predators, repair of pond facilities and propagation of natural food through pond fertilization and water management.

Drying the pond bottom can take a week or two. Undrainable portions of ponds such as water pools require pesticide application to eliminate unwanted species. Most insecticides commonly used contain chlorinated hydrocarbons which are non-biodegradable and may have some residual effects, leading to soil sterility and stunted growth in animals, and mortalities.

Some organic-based pesticides are safe and effective materials for pest and predator control. Rotenone powder preparation (5-8% rotenone) at a 5 ppm concentration or derris root at 20-40 kg/ha at 10 cm water depth can eliminate pests and finfishes. Tobacco dust or shavings are also effective at 200-400 kg/ha in eliminating pests, fishes and even snails. Nicotine and saponin, if available and cheap, are effective in eliminating predatory fishes at 10-15 kg/ha and 1 ppm, respectively.

A cheap and easily available material is lime, in combination with ammonium sulfate at 500-1,000 kg/ha and 100-200 kg/ha, respectively, or a ratio of 5:1. If the above materials are mixed, the ammonia released from ammonium sulfate becomes toxic when pH is raised above 9 because of lime. The pond may be flooded and stocked with fry immediately after application.

Other chemical compounds recommended for use are sodium hypochlorite (active chlorine 5%) which is available as a bleaching solution and calcium hypochlorite, a commercial powder with 75% active chlorine. Both compounds are effective at 5 ppm concentration.

The most commonly used fertilizer in the industry is chicken manure applied at 1-2 ton/ha. Pig and cattle manure, mud press and, to some extent, rice bran and rice straw are also utilized. The organic and inorganic fertilizer combination used depends largely on soil and water conditions as well as type of food. Normally, organic fertilizer application is followed by inorganic fertilization at 75-150 kg/ha of 16-20-0 and 25-50 kg/ha of urea (46% N). The propagation of *Ruppia maritima* requires 15 kg N/ha plus 15 kg P/ha applied every 2 weeks (P. Subosa, pers. comm.).

Stocking

Juveniles reared in a nursery pond or in a net enclosure (Fig. 3A, B) adjacent to or within the grow-out pond area are merely transferred or released without acclimation or without packing while tank-reared juveniles require acclimation to pond conditions. Failure to acclimate fry during stocking has been a common mistake committed by fishfarmers. In many cases, farmers do not even measure salinity and temperature of transport water and pond water. At present, prawn farmers may specify to hatchery or nursery sources their salinity preference based on condition of the pond prior to packing and transport of fry. This practice eliminates the need for salinity adjustment during stocking.

Stocking density is dependent on the culture system including food availability, water depth, and efficiency in water management. Fishfarmers engaged in extensive operations stock 2,000-6,000 *P. monodon* fry/ha or 20,000-30,000/ha in the case of *P. indicus*. When natural food is abundant, about 500-2,000 milkfish fry/ha are added. The presence of prawn or shrimp together with milkfish is favorable to both species. Results obtained from various polyculture studies of milkfish and prawn or milkfish, prawn and shrimp (Pudadera, 1980; Eldam and Primavera, 1981; Apud et al., 1983) confirmed

several beneficial effects. Eldani and Primavera (1981) specifically pointed out that one of the important benefits of prawn in polyculture with milkfish is their control of the population of chironomid larvae. These can occur at very high density (40,000-50,000/m²) and compete with the favored stock for food, oxygen and space. Gundermann and Popper (1977) reported the disappearance of *Chironomus* larvae in Fiji ponds several weeks after stocking with *P. merguensis* and *P. indicus*.

Stocking densities in semi-intensive operations may vary from 20,000 to 50,000/ha for *P. monodon* and 50,000 to 100,000/ha for *P. indicus*. These density levels are based on industry experience and the results of various studies on the intensification of prawn grow-out at the SEAFDEC Aquaculture Department Leganes Research Station (Mochizuki, 1979; Apud et al., 1981; Norfolk et al., 1981). At these density levels, it is possible to obtain survival rates ranging from 70 to 80% for *P. monodon* and 60 to 70% for *P. indicus*. Growth however, is highly dependent on water management and depth as well as the quality of supplementary feed.

Rearing

Extensive farming of prawn and shrimp relies heavily on natural food grown in the pond. Supplementary feeds are provided only occasionally when natural food production is low and stocking density is higher than 5,000 *P. monodon*/ha or 20,000 *P. indicus*/ha. In contrast, densities ranging from 20,000-30,000 *P. monodon*/ha and 50,000-100,000 *P. indicus*/ha in semi-intensive culture require regular supplementary feeding in addition to natural foods.

The natural food growing in prawn and shrimp ponds varies according to pond condition and location. Extensive culture as practised in northern Panay, parts of Bataan, Bulacan, Pangasinan, Samar, Leyte and some areas in Mindanao depends to a great extent on aquatic plants. The two most important species are *Najas graminea* and *Ruppia maritima*. Both plants normally occur in lower salinity (10-20 ppt) areas. *R. maritima* has a crude protein content of 15% (Apud et al., 1983). Both grow well in water 50-100 cm deep. Prawns

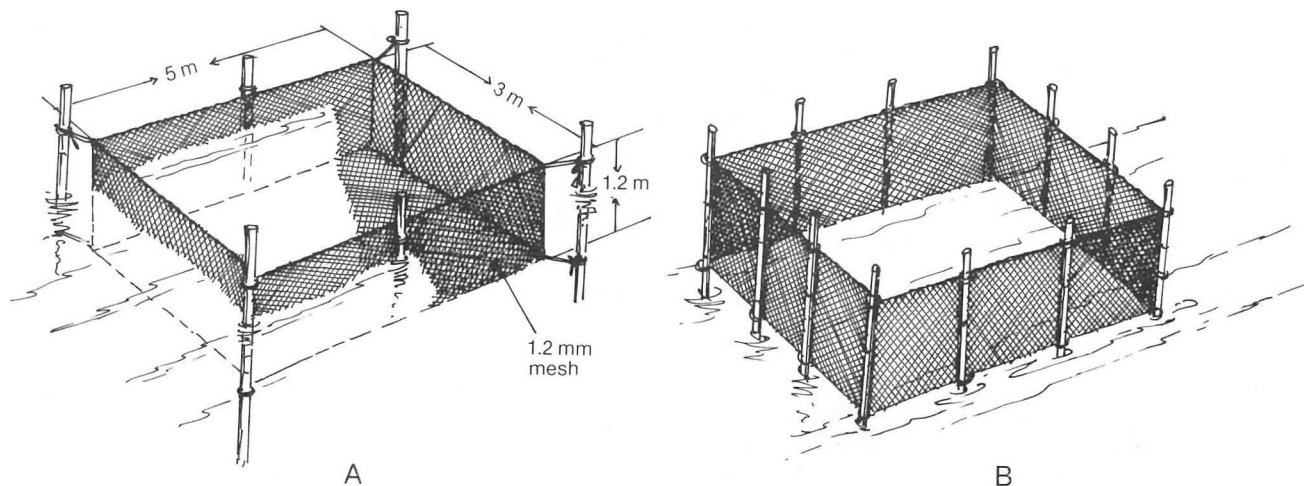

Fig. 3. Hapa prawn nurseries: A, hapa nursery in pond and B, net enclosure.

and shrimps graze on the soft parts of the plants, associated small animals (copepods, ostracods, insect larvae, nematodes, snails, etc.) and particularly on the decaying remains of the plants on the pond bottom (Primavera and Gacutan, 1984). The plants likewise provide shelter or substrate and improve water quality as silt and other particles are deposited on their leaves and stems.

Filamentous green algae such as *Chaetomorpha* constitute another natural food grown in ponds. *Chaetomorpha* grows in low salinity at water depth of 60 cm or more. It is also a refuge for various animals which are eaten by prawns and shrimps. The excessive growth of algae can cause harm by entangling the fry. This can be remedied by stocking milkfish at recommended polyculture rates. In some cases, ponds heavily loaded with these algae are drained completely by fishfarmers prior to stocking. Inorganic fertilizers are then broadcast directly into the mat of algae to soften the plants through plasmolysis.

Plankton, the microscopic plants and animals suspended in the water, form the base of the food chain. Deep ponds of low to medium salinity (10-30 ppt) are conducive to plankton growth.

Lablab, a microbenthic complex consisting of blue-green algae, diatoms, and other microscopic plants and animals, is considered a nutritious food for milkfish and even for prawns and shrimps. However, the environmental conditions under which it grows best (shallow water of 20-25 cm depth and higher salinity, 28 ppt and above) are not suited to prawn and shrimp. Also, the pond bottom easily deteriorates with excessive growth of lablab whose decomposition produces sulfides and other toxic gases and at the same time depletes oxygen on the pond bottom. Prawns and shrimps lose appetite at oxygen level of 3 ppm and below, hence lablab is not considered a good natural food for prawns unlike milkfish (Apud et al., 1983).

Although the stock in extensive ponds relies greatly on natural food, some farmers provide various kinds of supplementary feeds such as trash fish, mussel meat, toads, chicken entrails, cattle hide, snails, etc. In semi-intensive culture, processed feeds (formulated diet) and/or trash fish (Apud et al., 1981) are stored to provide adequate and ready supply of feeds in case unprocessed feeds are not available.

The amount of feeds and frequency of feeding are not yet well established. However, the daily recommended rates which decrease with time are 15-10% of estimated total biomass of prawns and shrimps for wet feeds and 10-4% for dry pellets. Forty percent of the feed is given in the morning and 60% in the evening. Feeds are placed in feeding trays and inspected a few hours after feeding to check whether the feeds are consumed or not.

There are relatively few cases of disease problems reported in extensive and semi-intensive operations. The most common complaint of fishfarmers is soft-shelling of prawns, a condition which inhibits molting and therefore results in retarded growth. Soft-shelled prawns are weak compared to those who undergo normal molting. Soft-shelling is attributed to possible factors like presence of microbes, nutritional deficiency and poor environmental conditions (C. Baticados, pers. comm.). This may also be caused by trace

amounts of insecticides applied to adjoining agricultural areas. Proper water management and adequate food supply could prevent the occurrence of these problems.

Other diseases infrequently observed are the "black gill" disease caused by fungi or protozoa and a condition indicated by necrosis of appendages characterized by the browning of pleopods, pereopods, telson and uropods at the earlier stages. This browning usually spreads progressively from the focus of infection towards the base of the appendages and finally leads to the erosion of some areas. According to Gacutan (1979), the etiology of this disease has not yet been determined; however, shell disease of this nature as in other penaeids can be caused by chitinoclastic bacteria such as *Benneckeia*, *Vibrio* and *Pseudomonas* (Cook and Lofton, 1973). The progressive destruction of the exoskeleton provides areas for the entry of secondary infection which may cause death.

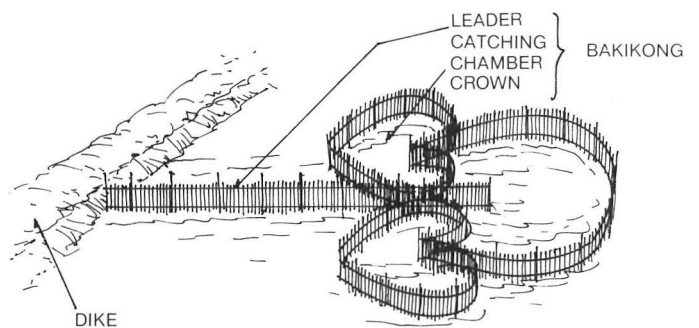

Fig. 4. Bamboo trap (*bakikong*) commonly used for partial harvesting.

Body cramp is another problem usually encountered during handling, transfer or harvesting during hot days. The body of a cramped prawn curves and becomes rigid, oftentimes leading to death. This may be avoided if prawns are handled or transferred during cool days. Fuzzy growth of algae on the exoskeleton is another disease. It may be caused by bacteria, protozoans or algae. These are associated with poor water quality and high organic matter content. Molting is inhibited and growth is retarded.

The occurrence of pests and predators cannot be totally avoided during the culture period. Most common are tilapia, gobies, small crabs, tarpon (*Megalops cyprinoides*), ten-pounder (*Elops hawaiiensis*), seabass (*Lates calcarifer*), etc. The elimination of predators during the culture period is a difficult problem encountered in the industry. So far, minimizing the population of tilapia is being done by the use of cast net. In the case of gobies, collection by feeding trays or traps are resorted to. Both measures may help at best but do not completely solve the problem.

Some fishfarmers have tried using selective pesticides such as rotenone or saponin to eradicate unwanted species during the culture period. However, supply of these products is scarce. The possibility of developing techniques for selective elimination with locally available derris root is promising. A bioassay of powdered derris root (Tumanda, 1980) indicated its selective effect. At 5-10 ppm, the powdered material kills tilapia, tarpon, ten-pounder, milkfish and other finfishes while leaving *P. monodon* unaffected.

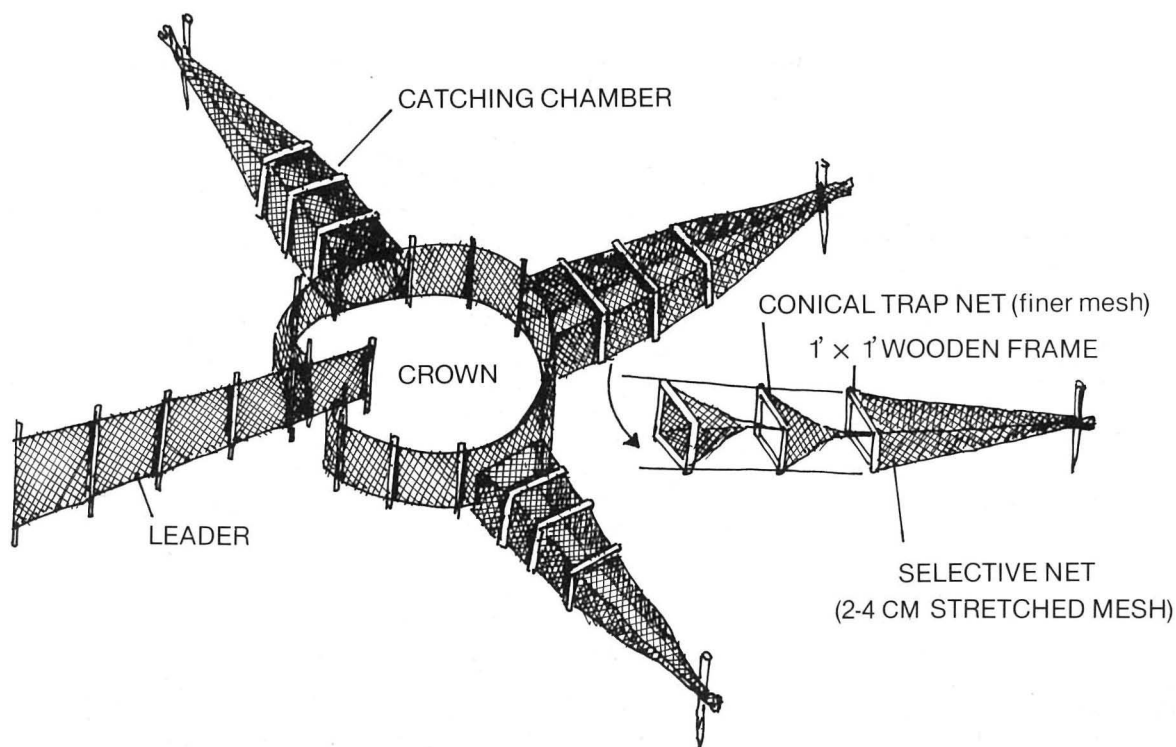

Fig. 5. Selective harvesting net collects only large prawns, undersized stock pass through the net (after Suemitsu, 1983 in Apud et al., 1983).

Harvesting and postharvest handling

In extensive and semi-intensive operations, most fish-farmers usually synchronize harvest with the spring tide during New Moon. It has been observed that prawns are more active during this time. Likewise, there is a greater percentage of hard-shelled shrimps two or three days after the peak of spring tide. If the timing is off, a greater percentage (20-50%) of harvest is soft-shelled. If soft-shelling is caused by normal molting, such can be avoided by inducing them to molt almost at the same time (V. Mancebo, pers. comm.). This is done by abruptly changing pond water four to five days before the scheduled harvest (during spring tide) preferably two days before peak of the highest tide. If the prawns are successfully induced to molt by brief exposure to stressful conditions such as sudden water change, only 5% may be soft-shelled, four to five days after such change.

Partial harvesting is undertaken when there is a wide range of sizes in ponds. Harvest gear popularly utilized for this purpose are bamboo traps (Fig. 4) and cast nets. The most effective gear recently introduced by the SEAFDEC Aquaculture Department is a pound net (Fig. 5) developed in Japan. This is a selective type of gear where smaller shrimps can easily pass through the net mesh used in this trap.

Farmers also attract prawns to traps by placing light over them in the evening. Cast net harvesting is made more effective by placing feed in certain areas where the net is cast. Partial harvest is convenient and can demand better prices for small batches of 20-100 kg per delivery to buyers. Partial harvesting is resorted to by some farmers in Bataan, Pampanga and Bulacan to meet the daily prawn and shrimp re-

quirements of hotels and restaurants in Metro Manila. The advantage of this practice is that the total yield per hectare increases by about 20% (M. Suemitsu, pers. comm.) while the product gets consistently higher prices than when sold in the market at one time.

Total harvest is commonly done using a bagnet (Fig. 6) positioned so that it collects prawns that go with the current while draining the pond. As in partial harvesting, the prawns are initially stimulated to move by partial draining of the pond (30-70%) in the daytime a few hours before the incoming high tide after which the pond is flooded to maximum level during high tide.

In wide extensive ponds (10-20 ha), harvest by this method is oftentimes difficult especially when prawns are not so active. Considering the relatively large area, water manipulation is not effective in stimulating prawn movement. In many cases, the farmers resort to total draining or seining of trenches, and handpicking. While it takes much effort and time to pick up prawns from the pools and mud, prawns harvested this way easily deteriorate and therefore are not accorded the best price in the market. In semi-intensive ponds, the prawns can be easily stimulated to move. Thus harvest is more convenient, whether partial or total.

Another harvesting method that is practised by farmers in Bulacan and some other provinces is the use of a large suspension net (Fig. 7) installed at the drain portion of the gate. Its advantage over the bagnet is that prawns can be accumulated in the nets either by allowing them to swim against the current when flooding with tidal water or allowing them to go with the current when draining the pond. The large area

(50-60 m²) of the net allows the fishfarmer to keep the harvested prawns or shrimps alive until a sufficient number is collected.

A recommended method of handling newly harvested prawns or shrimps is to transfer them from any harvesting gear into small bagnets in quantities not exceeding 10 kg. They are then washed thoroughly in the pond or in a tank after which the prawns inside the bags are immediately immersed in chilled freshwater (10°C) preferably while still alive. After 10 minutes or more in chilled water, the bags can be retrieved and the prawns are spread on the table or in baskets for classification.

Depending on the preference of the buyer, prawns, particularly *P. monodon*, are classified into different size groups, e.g., 6-18, 19-25, 26-40, and 41-45 pcs/kg. All prawns with sizes of at least 41 pcs/kg and those that are soft-shelled are bought at a much lower price or completely rejected. Another classification practised by buyers in Negros is 20 and below, 21-30, 31-40, and 41-50 pcs/kg. The last group plus the soft-shelled prawns are also rejected or bought at a much lower price. Prices fluctuate every now and then. White shrimp, e.g. *P. indicus* are usually classified into three categories, namely: large, 50-70 pcs/kg; medium, 80-100 pcs/kg; and small, 110 pcs and above/kg.

Problems and prospects

Problems

There are various problems confronting the industry today. A common problem is associated with marketing. Many fishfarmers complain about the classification and pricing pattern adopted by some exporters. It is alleged that there is a big disparity in pricing between first class prawns whose price is P120-150/kg, second class at only P90/kg and third

class at P70/kg. The bulk of the processed products fall within the second and third classes.

Despite the proliferation of hatcheries, fry supply especially in Luzon is inadequate during some cropping periods. Lack of fry results in late and staggered stocking, thus adversely affecting production. Hatchery operators who own farms give priority to their own requirement before selling fry to others. Also, production in hatcheries is seasonal like wild fry supply so that prices also fluctuate according to demand.

Feed and feeding requirements have not yet been standardized. Many food sources and feeding practices have been tried but the results are as varied as the kind of feed and feeding scheme used. Likewise, the selling price of prawn has not kept up with the increase in imported and even local ingredients for processed feeds and cost of production.

There is a serious shortage of technical manpower in the industry. Big entrepreneurs usually employ the services of Taiwanese and Japanese technicians who are paid high rates. Local technicians who are as capable as foreign ones are employed by farmers who can hardly afford to offer better incentive. The major source of hatchery technology and technicians in the country is the SEAFDEC Aquaculture Department.

Another source of complaint are inconsistent yields caused by various technical problems. These include retarded growth and high mortality caused by any or a combination of several factors such as soft-shelling, diseases, nutritional deficiency, low pH, extremely high or low salinities, low dissolved oxygen, high H₂S and NH₃ levels, pollution, inadequate or inappropriate pond facilities (shallow ponds and defective screening), presence of pests and predators in large quantities, mishandling, lack of proper acclimation during stocking or transfer, and inefficient water management.

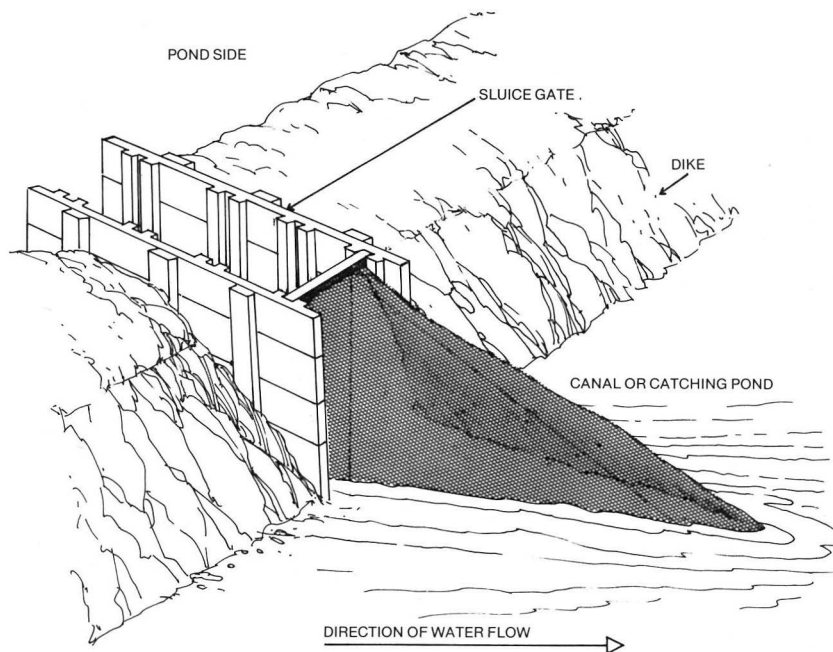

Fig. 6. Bagnet in operation.

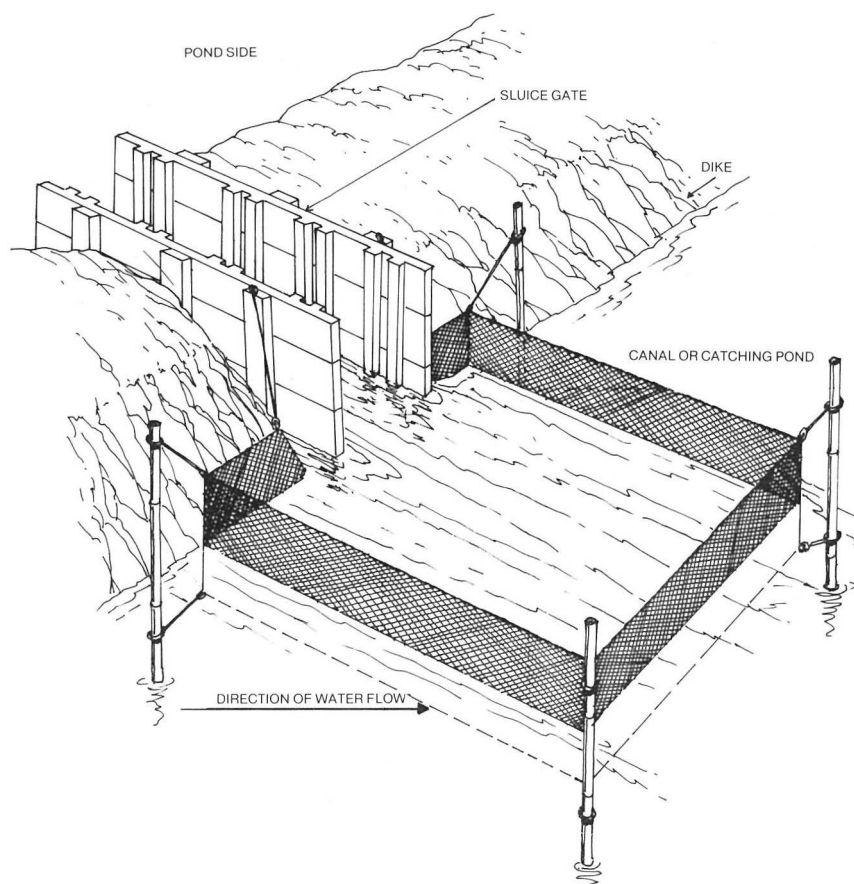

Fig. 7. Suspension net used for partial harvesting.

Prospects

There is a high market demand for frozen prawn and shrimp in the international market particularly in Japan, U.S.A. and Europe. It is evident that the potential for prawn and shrimp production in the Philippines is promising. The indigenous species, tiger prawns and white shrimps, have a bright prospect for intensified production. The Philippines has a warm climate, soil types and water quality all conducive to prawn and shrimp farming. A good portion of brackishwater ponds is also suitable for conversion into prawn and shrimp culture. The rapid progress and development of hatchery and nursery techniques will eventually solve the problem of inadequate fry supply, while the development of broodstock production and maturation techniques will solve inadequate spawner supply, a serious problem in hatcheries.

Conclusion and recommendations

Extensive farming is largely practised in many provinces of the country with consistent production in some areas. More expansion and improvements are expected within the next few years. Semi-intensive farming, on the other hand, is practised to a limited extent. Its further development will be dictated by the availability of fry at reasonable cost, supply of feed at lesser cost, availability of technical manpower, financial credit facilities, and cost of other inputs and improvements.

Market demand has not yet been saturated; however, there is a need to develop marketing strategies, methods of post-harvest handling, and transport of product to maintain high quality and command better price.

White shrimp farming has yet to be improved in order to achieve more profitable results. One aspect that should be studied is how to grow them bigger (15-25 g) in order to penetrate the international market. There is a high demand for white shrimps in the world market, and the market price is attractive. Local price for white shrimps is low, hence farmers are not as interested in its culture as compared with tiger prawn.

Although fry production has greatly increased due to the proliferation of hatcheries, fry supply is still inadequate to meet the increased demand resulting from expansion and improvements in pond culture. Thus, there is a need to produce fry all year round. Hatcheries should not be dependent on seasonal supply of spawners. Broodstock and maturation tanks should be maintained to meet spawner requirements.

The industry generally lacks supply of appropriate feeds, equipment, and other supplies. Both researchers and fish-farmers agree that food is one major limiting factor in the success of production. The kind of food and frequency of feeding, however, is not well established. To a large extent, feeding is looked upon by the industry as an added major input. The economics of feeding needs to be looked into and research on satisfactory local substitutes of imported ingredients should be continued.

There is a need to develop other support activities such as feed milling and storage, formulation and preparation of fertilizers, propagation of organic pesticides such as derris roots, and fabrication of blowers, paddlewheel, water pumps, different types of harvesting gear, and transport facilities.

The research, training and extension activities of various institutions involved in the development of prawn culture should be reviewed and restructured to suit the needs of industry.

The government should provide credit facilities at low interest rates and marketing incentive or protection so that producers will not be at the mercy of exporters. Strong fishfarmers' association or cooperatives are important in order to have collective bargaining power. Inputs can be acquired and marketing can be done through cooperatives for better profit.

References

- Apud, F.D. 1979. Effects of water movement and aeration system on the survival and growth of hatchery-bred supgo (*Penaeus monodon*) fry reared in earthen nursery ponds. M.S. thesis, Univ. of the Philippines in the Visayas, Iloilo, Philippines.
- Apud, F.D. 1982. Handling and rearing of hatchery produced shrimp postlarvae from small-scale hatcheries. SCS/GEN/82: 40 (FAO/UNDP-SCS), pp. 87-93.
- Apud, F.D. and M. Sheik. 1978. Design and construction of prawn nursery pond system. SEAFDEC Aquaculture Dept., Iloilo, Philippines, (mimeo).
- Apud, F.D., N. Deatras and K. Gonzales. 1981. Feeding behaviour and food preference of *Penaeus monodon* Fab. with scrap *Tilapia mossambica*. Fish. Res. J. Philipp., 6: 27-31.
- Apud, F.D., K. Gonzales and N. Deatras. 1981. Survival, growth and production of *Penaeus monodon* Fab. at different stocking densities in earthen ponds with flowthrough system and supplemental feeding. Fish. Res. J. Philipp., 6: 1-9.
- Apud, F.D., J.H. Primavera and P.L. Torres, Jr. 1983. Farming of prawns and shrimps (3rd ed.). Extension Manual No. 5, SEAFDEC Aquaculture Dept., 67 pp.
- Caces-Borja, P. and S.N. Rasalan. 1968. A review of the culture of supgo, *Penaeus monodon* Fabricius in the Philippines. Rome, FAO, 2: 111-123.
- Cook, D.W. and S.R. Lofton. 1973. Chitinoclastic bacteria associated with shell disease in *Penaeus* shrimp and the blue crab (*Callinectes sapidus*). J. Wildl. Dis., 19: 154-159.
- Delmendo, M.N. and H.R. Rabanal. 1956. Cultivation of supgo (Jumbo Tiger Shrimp), *Penaeus monodon* Fabricius in the Philippines. Proc. IPFC, 6(2-3): 424-431.
- Eldani, A. and J.H. Primavera. 1981. Effect of different stocking combinations on growth, production and survival of milkfish (*Chanos chanos* Forskal) and prawn (*Penaeus monodon* Fab.) in polyculture in brackishwater ponds. Aquaculture, 23: 59-72.
- Gacutan, R.Q. 1979. Diseases of prawns. Technical Consultation on Available Aquaculture Technology, SEAFDEC Aquaculture Dept., Iloilo, Philippines, Feb. 8-11, 1979, 13 pp.
- Gundermann, N. and D. Popper. 1975. Experiment in growing *Penaeus merguensis* (de Man 1888) in a fish pond in Fiji. Aquaculture, 6: 197-198.
- Marte, C.L. 1978. The food and feeding habit of *Penaeus monodon* Fab. collected from Makato River, Aklan, Philippines. Crustaceana, 38(3): 225-236.
- Mochizuki, H. 1979. The present prawn culture in the Philippines. Terminal Report, SEAFDEC Aquaculture Dept., 60 pp. + 33 figs. (mimeo).
- Motoh, H. 1981. Studies on the fisheries biology of the giant tiger prawn, *Penaeus monodon* in the Philippines. Tech. Rep. No. 7, SEAFDEC Aquaculture Dept., 128 pp.
- Norfolk, J.R.W. 1981. The use of ammonium sulfate as a pesticide during pond preparation. Asian Aquaculture, 4: 7.
- Norfolk, J.R.W., J.N. Paw and D.S. Javellana. 1981. A preliminary report on intensification of prawn grow-out at SEAFDEC Leganes Research Station: Perspectives, problems and prospects, 10 pp. + 4 figs., 7 tables.
- Peña, D. dela, Jr., and T. Young. 1984. Floating cage nursery culture system for *Penaeus monodon*. First Intl. Conference on the Culture of Penaeid Prawns/Shrimps, Iloilo City, Philippines, Dec. 4-7, 1984 (abstract).
- Platon, R.R. 1979. Present status of prawn farming in the Philippines. Technical Consultation on Available Aquaculture Technology. SEAFDEC Aquaculture Dept., Iloilo, Philippines, Feb. 8-11, 1979, 22 pp.
- Primavera, J.H. 1976. Survival rates of different *Penaeus monodon* postlarval stages. Philipp. J. Sci., 105(3): 103-109.
- Primavera, J.H. 1984. Seed production and the prawn industry in the Philippines. In: Prawn industry development in the Philippines. SEAFDEC Aquaculture Dept., pp. 33-53.
- Primavera, J.H. and F.D. Apud. 1977. Manual of operations: Supgo pond culture. Extension Manual No. 2, SEAFDEC Aquaculture Dept., 18 pp.
- Primavera, J.H. and R.Q. Gacutan. 1984. *Ruppia maritima* and *Najas graminea* as natural foods for *Penaeus monodon* juveniles. First Intl. Conference on the Culture of Penaeid Prawns/Shrimps. Iloilo City, Philippines, Dec. 4-7, 1984 (abstract).
- Primavera, J.H., F.D. Apud and C. Usigan. 1976. Effects of different stocking densities on survival and growth of supgo (*Penaeus monodon* Fab.) in a milkfish rearing pond. Philipp. J. Sci., 105(3): 193-203.
- Pudadera, B., Jr. 1980. Evaluation of milkfish (*Chanos chanos* Forskal) and prawn (*Penaeus monodon* Fab.) in polyculture systems. M.S. thesis, Univ. of the Philippines in the Visayas, Iloilo, Philippines.
- Tan, G. 1984. The processing and exporting of prawns in the Philippines. In: Prawn industry development in Philippines. SEAFDEC Aquaculture Dept., pp. 83-87.
- Tang, Y.A. 1961. The use of saponin to control predaceous fishes in shrimp ponds. Prog. Fish-Cult., 23(1): 43-65.
- Torres, P.L., Jr. 1983. Fishpond design and construction. SEAFDEC Aquaculture Dept., Iloilo, Philippines, 17 pp. + 14 figs., 1 table (mimeo).
- Tumanda, M.I., Jr. 1980. The effect of rotenone-containing derris plant extracts on the mortality of some predator fishes of pond-cultured prawns under different water temperature-salinity combinations. M.S. thesis, Univ. of San Carlos, Cebu City, Philippines, 89 pp.
- Villadolid, V. and D.K. Villaluz. 1951. The cultivation of supgo (*Penaeus monodon* Fab.) in the Philippines. Philipp. J. Fish., 1: 55-56.
- Villaluz, D.K. 1953. Fish farming in the Philippines. Bookman, Manila, pp. 137-148.