

**Southeast Asian Fisheries Development Center**

**Aquaculture Department**

**SEAFDEC/AQD Institutional Repository**

**<http://repository.seafdec.org.ph>**

---

Journals/Magazines

Aqua Farm News

---

1990

# Operating a milkfish hatchery

Aquaculture Department, Southeast Asian Fisheries Development Center

---

Southeast Asian Fisheries Development Center, Aquaculture Department (1990). Operating a milkfish hatchery. Aqua Farm News, 8(3), 3-10.

---

<http://hdl.handle.net/10862/2647>

---

*Downloaded from <http://repository.seafdec.org.ph>, SEAFDEC/AQD's Institutional Repository*

such as *Chlorella*, *Tetraselmis* and *Isochrysis* as well as rotifers are also suitable.

For shrimp larvae, diatoms and *Tetraselmis* are particularly suitable for feeding of zoea followed by *Artemia* for mysis. In the later stages, *Artemia* and/or pellets are used.

- *Diseases and their control.* Disease outbreaks could be controlled through proper cleaning and adoption of good sanitation and hygiene practices throughout hatchery operations. Various drugs are available in the market for controlling disease outbreaks including malachite green or treflan, chloramphenicol, oxytetracycline (OTC), and formalin. Proper nutrition and water quality maintenance to prevent disease are, however, more important than control itself.

- *Harvesting.* Harvesting of fish/shrimp larvae should be carefully done using a scoop net or bag net.

- *Transportation.* The mode of transport varies slightly with species and distance involved. Various containers could be used, such as polyethylene bags and bamboo baskets. The use of clean water, and the incorporation of antimetabolites and other suitable chemicals are considerations for reducing mortality.

Source: Gerald L. Roessink, **INFOFISH International**, September-October 1989.

## OPERATING A MILKFISH HATCHERY

Mass production of milkfish fry is now possible!

The technology for operating a milkfish hatchery has come of age after over a decade of research work on milkfish at SEAFDEC/AQD: from the development of broodstock technology; to induction of spawning and larval rearing since 1977; to regular spontaneous spawning of broodstock in captivity during the breeding season since 1980; to completion of the life cycle in 1983; to development of techniques for collection of spawned eggs in 1986.

The supply of wild milkfish fry is often unpredictable and the catch in recent years has apparently diminished. Moreover, the recent trend toward semi-intensive culture is expected to create a heavier demand for fry which may not be met by the supply from traditional sources. Hatchery production of fry can stabilize the supply of seeds and eventually promote increased production of milkfish, an important food fish in the Philippines.

Naturally spawned milkfish eggs may be secured from the SEAFDEC Aquaculture Department and from the National Bangus Breeding Program (NBBP) project sites of BFAR in Alaminos, Pangasinan; Calape, Bohol; and Sta. Cruz, Davao del Sur.

### Item One: Tanks and Equipment

A milkfish hatchery needs larval rearing tanks, culture tanks for rotifer (*Brachionus*) and green algae (*Chlorella*), and hatching tanks for the brine shrimp (*Artemia*). A volume ratio of 1 ton larval rearing tank to 3 tons algal and rotifer tank is recommended. Tanks should be easily drained through a harvesting canal. A layout of a typical milkfish hatchery is shown in Figure 1.

**Larval Rearing Tank.** Circular canvas or concrete tanks with an airstone at the center may be used. Larger tanks may be used; however, tanks of smaller volumes are preferred for easy management. Larval rearing tanks should be placed under a shade to protect the larvae from the glare and heat of direct sunlight and to deter growth of diatoms that contribute to poor water quality.

**Algal/Rotifer Tank.** Square, rectangular or circular canvas or concrete tanks may be used for mass production of *Chlorella* and *Brachionus*. To maximize tank usage, tanks for algae are also used to culture rotifer.

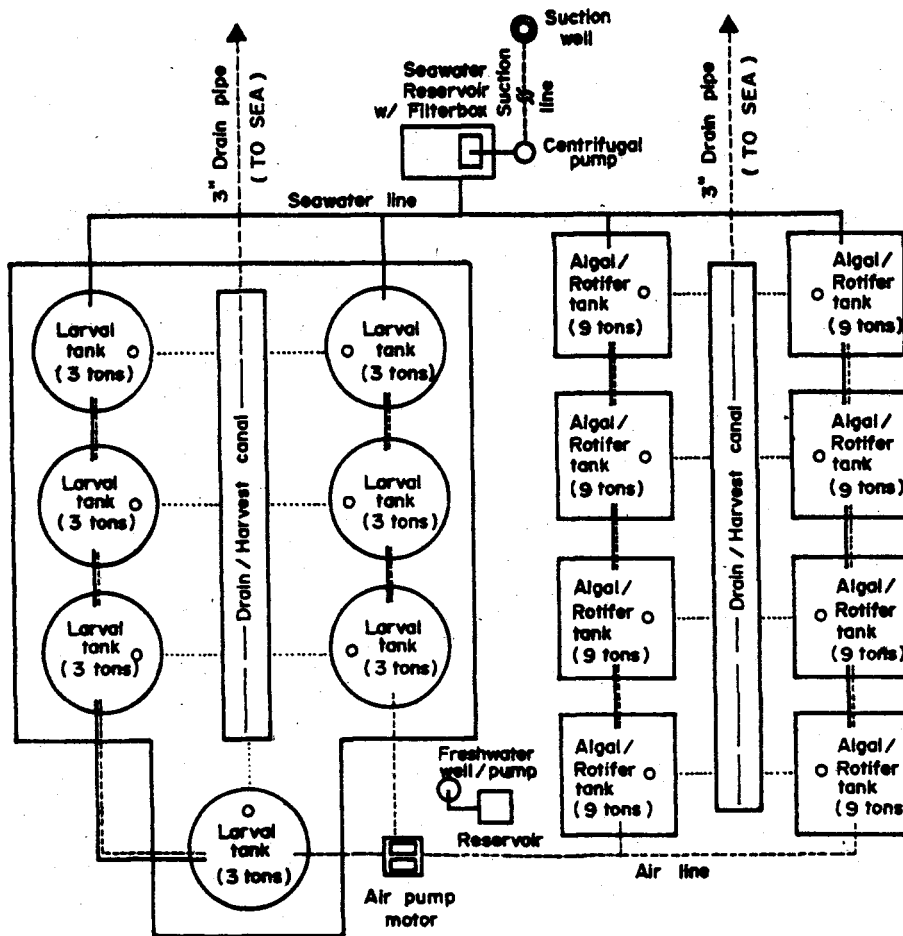

Fig. 1. Layout of a typical small-scale milkfish hatchery.

**Brine Shrimp Hatching Tank.** A cylindro-conical plexiglass, transparent conical fiberglass, or plastic carbuoy may be used in hatching *Artemia* cysts. The capacity of the hatching container varies depending on the amount of *Artemia* to be hatched.

**Seawater Storage Tank** A seawater tank with a capacity of at least 50% of the total volume of culture tanks is recommended. Storage tank should be elevated so that filtered seawater can be distributed to all tanks by gravity flow (Fig. 2).

A milkfish hatchery should have the following equipment:

**Seawater centrifugal pump** (2 HP) for pumping prefiltered seawater from the suction well to filter tank and reservoir.

**Air blower** (1.5 HP) provides aeration to all tanks.

**Submersible pump** (1/3 HP) for mass transfer of algae to rotifer tanks.

**Freshwater pump** (1/3 HP) draws freshwater from a shallow well for hatchery use.

**Standby generator** (5 KVA) should be available in case of power failure.

**Stereomicroscope** for estimating density of rotifer, egg, and larval samples.

**Weighing scales** : (i) 1-kilogram capacity for weighing *Artemia* cysts and (ii) 10-kilogram capacity for weighing fertilizers.

Spare pumps should be provided in case of breakdown.

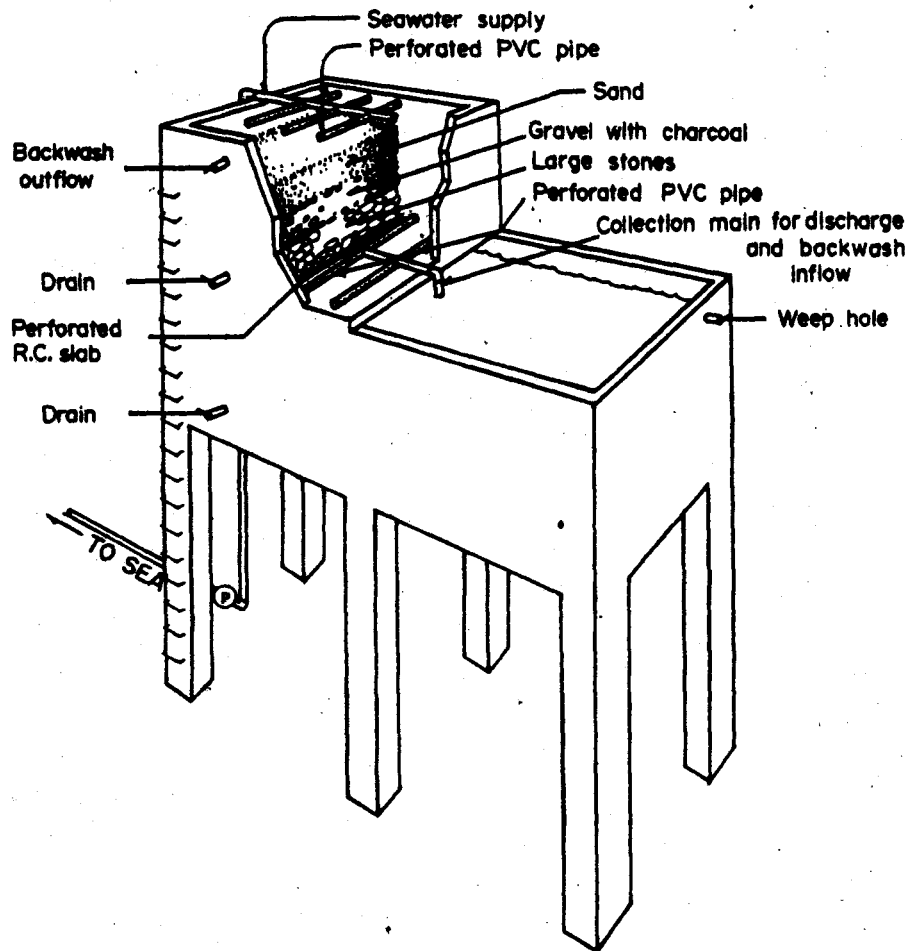

Fig. 2. Elevated seawater reservoir with cut-out diagram of its sand filter.

### Item Two: Packing and Transporting Milkfish Eggs

Eggs should be handled carefully and transferred as soon as possible to the hatching tanks. When transport to the hatchery site takes more than one hour, it is advisable to pack and transport 6 hours after spawning, that is, when eggs are already at a more advanced stage of embryonic development. About one hour before transport, eggs are packed following these steps:

- 1) Turn off aeration and gently swirl the water once or twice in order to concentrate dead eggs to the bottom of the container. Quickly siphon out these dead eggs by using a rubber or plastic tubing.

- 2) Slowly drain to one-half the volume of water suspending the collected eggs. This is done by siphoning out the water with the nozzle of the tube wrapped with screen net or filter so that live eggs are excluded.

- 3) Layer *pandan* bags (*bayong*) with 2-3 inches of rice hull, 2 liters of crushed ice, and another layer of rice hull in that order (Fig. 3).

- 4) Into each prepared *bayong*, set a double-layered plastic bag containing 15 liters of seawater with a salinity of 20-35 ppt. Note that milkfish eggs tend to sink in seawater with salinities of 25 ppt or less; these eggs are not dead and will float when transferred to higher salinities.

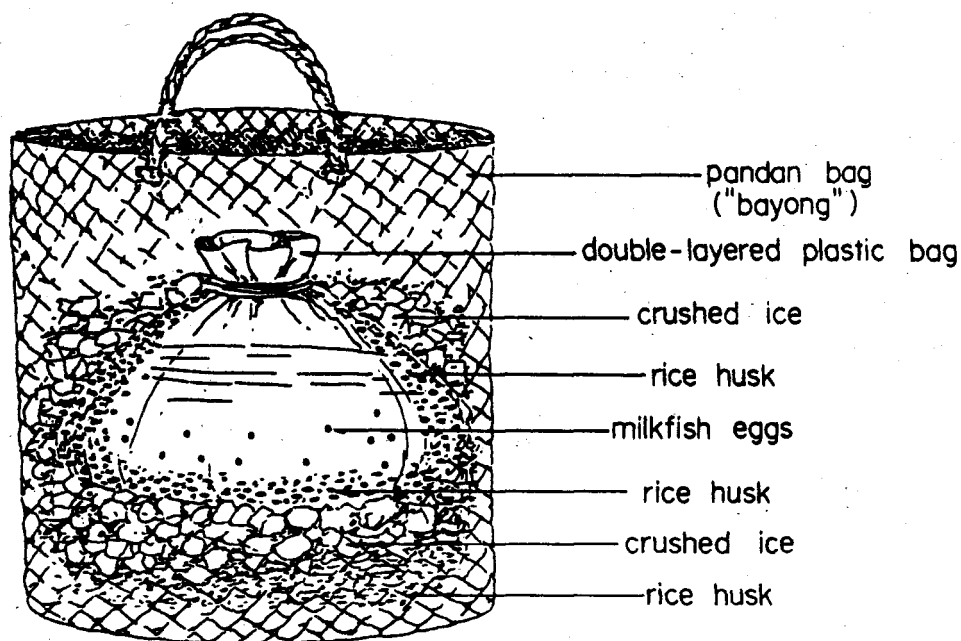

Fig. 3. *Bayong* bag for transporting milkfish eggs.

- 5) Using a fine scoop net (pore size, 0.6-0.8 millimeter), gently concentrate a scoopful of eggs.
- 6) Gently scoop out with a beaker 150 milliliters of eggs from the net and quickly transfer into the bag of water in the *bayong*. About 100 milliliters has approximately 60,000 eggs. Never place more than 150 milliliters of eggs into each bag of 15 liters seawater in the *bayong*.
- 7) Fill to inflate each plastic bag with oxygen and seal tightly with rubber bands.
- 8) Place half a liter of crushed ice and some rice hull on top of each plastic bag of eggs.
- 9) *Bayong* bags must be kept under shade during transport, but make sure water temperature in the bags does not go down to 20°C or lower throughout the trip. The ideal water temperature in the *bayong* is 28°C for at least 2 hours.

### Item Three: Preparing Hatching and Larval Rearing Tanks

Hatching occurs in 14 to 16 hours after collection. Hatchery and larval rearing tanks therefore have to be prepared at least one day before eggs are obtained.

**Preparation of Hatching and Larval Rearing Tanks.** (1) Thoroughly scrub with scrubbing pad or nylon brush and detergent the 500-liter fiberglass hatching tanks and 3-ton larval rearing tanks. Rinse well with seawater or freshwater. (2) Fill up the tanks, preferably with freshwater, and disinfect by chlorination

#### **Chlorination Procedure for Disinfection:**

(1) Determine capacity (water volume) of tank to be disinfected. (2) To obtain a 200 ppm solution, calculate the amount of chlorine powder or granules to be used from the following information:

- 1 gram/1000 liters of water = 1 ppm
- 1 milligram/liter of water = 1 ppm

Example:

For a 3.0-ton (3000-liter) capacity tank, determine the amount of chlorine granules to obtain

a 200 ppm solution.

If 1 gram/1000 liters = 1 ppm, then 200 gram/1000 liters  
= 200 ppm

Therefore:

$$\frac{200 \text{ grams}}{x} = \frac{1000 \text{ liters}}{3000 \text{ liters}}$$

x = 600 grams of chlorine granules to be dissolved  
in 3000 liters of water to make 200 ppm solution

(3) After computing for the amount of chlorine granules needed, weigh out the desired amount. Dissolve this in a small amount of freshwater before adding to the tank to be disinfected. Mix well. (4) Let stand overnight. Drain water the following day. Clean the tank by scrubbing with sponge and detergent. Rinse thoroughly and let dry.

#### **Item Four: Hatching Milkfish Eggs**

Procedures for hatching milkfish eggs are as follows:

- 1) Fill up hatching tank with filtered seawater. To estimate the number of hatching tanks needed, allow a density of 300 eggs/liter for optimum hatching. Eggs are packed in double-layered oxygenated plastic bags usually at a density of 8,000 eggs/liter of transport water.
- 2) Upon arrival of eggs at the hatchery, let the plastic bag float in the hatching tank for 15 minutes to allow temperature in the bag to equilibrate with the temperature in the hatching tank. Allow small amounts of water in the hatching tank to intermix slowly with water in the transport bag before gently pouring the content of the bag into the hatching tank.
- 3) Stock not more than 300 eggs/liter. Aerate moderately to prevent aggregation of eggs.
- 4) Wait for about 15-30 minutes, then stop aeration. Gently swirl the water and wait until water motion stops. Siphon out unfertilized and dead eggs at the bottom of the tank.
- 5) Flow-through filtered seawater into the hatching tank for 1-2 hours.
- 6) Milkfish eggs at 28-29°C usually hatch within 24-26 hours after spawning or 14-16 hours after collection. When hatching is completed, siphon out egg cases, dead eggs and other debris.

#### **Item Five: Food Organisms for Milkfish Larvae**

The food organisms used for rearing milkfish larvae are the unicellular green alga *Chlorella*, the rotifer *Brachionus*, and the brine shrimp *Artemia*. Green algae aid in maintaining good water quality in the larval rearing tank and serve as food for *Brachionus*. Milkfish larvae are fed with rotifers throughout the whole rearing period. Brine shrimp nauplii are fed on the 15th day to the 21st day when larvae are usually harvested.

Mass culture of food organisms has to be started at least one month before larval rearing commences. Small-scale indoor culture of these food organisms in fiberglass tanks precedes large-scale culture in canvas or concrete tanks.

The procedure for culturing starters of *Chlorella* and *Brachionus* in indoor facilities and then in outdoor tanks follows. Figure 4 illustrates programming of both culture operations.

*Chlorella* and *Brachionus* starters may be obtained from research institutions or from other hatcheries. *Artemia* cysts, on the other hand, are available from aquaculture supply stores. Quality *Artemia* strains with high hatching efficiency are preferred.

#### **Item Six: Larval Rearing**

Water management and feeding (Fig. 5) during the larval stage are as follows:

- 1) Maintain mild aeration during the first week of rearing. Should water in rearing tanks turns

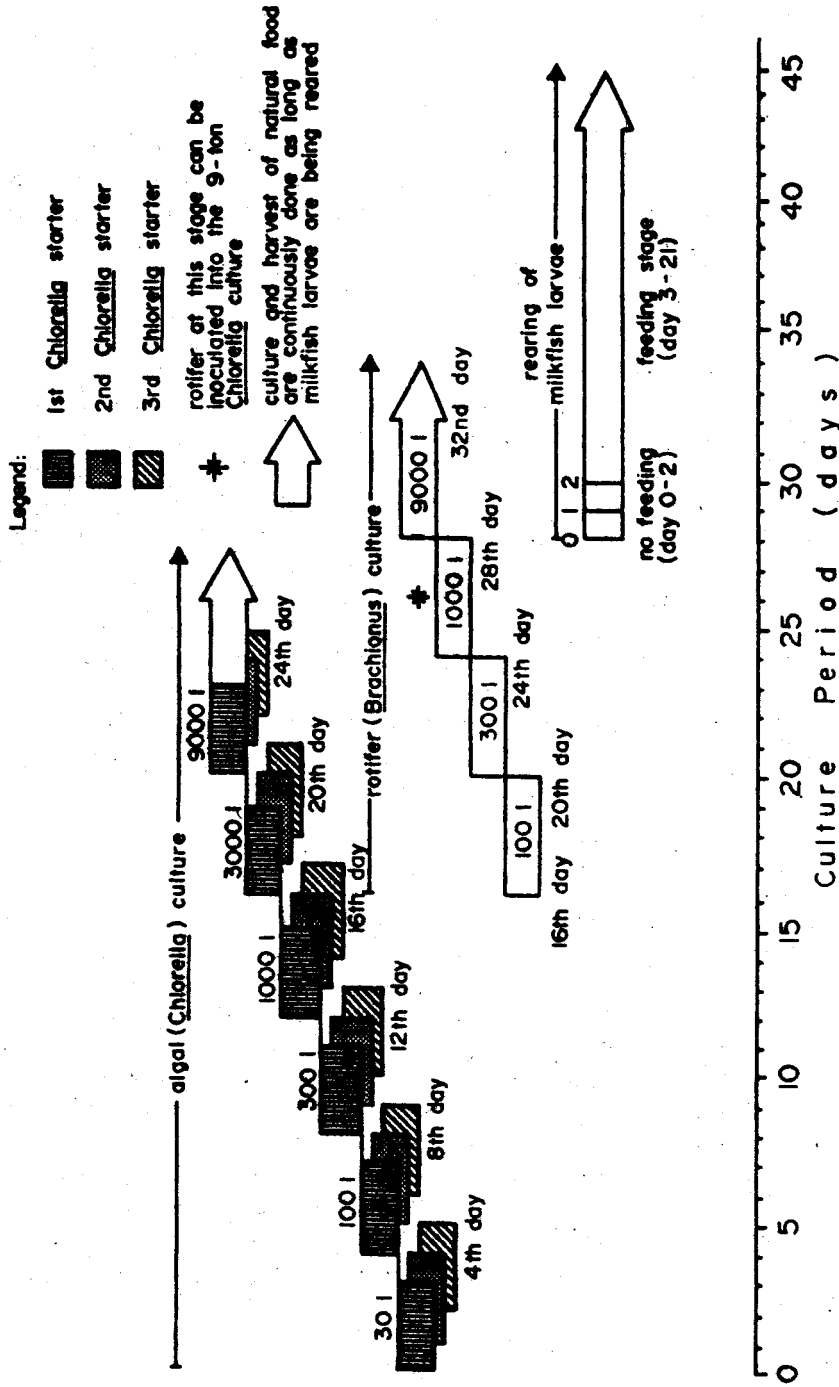

Fig. 4. Programming of natural food culture for milkfish hatchery operations.

pale, add enough *Chlorella* to restore the green-to-light-green color. *Chlorella* should be added preferably in the morning before feeding the larvae.

2) Starting on day 2 until day 14, add *Brachionus* at 10-15 individuals/milliliter.

3) *Artemia* nauplii at 0.5 individual/milliliter are fed from day 15 to day 17. Increase feeding level to 1 individual/milliliter from day 18 until harvest (day 21).

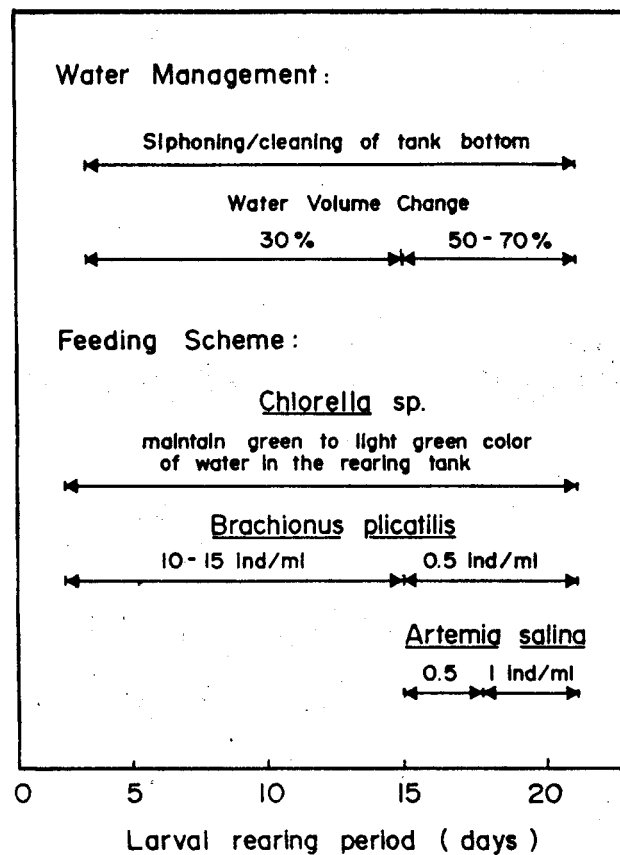

Fig. 5. Water management and feeding scheme for rearing milkfish larvae.

4) Siphon out wastes and uneaten food in the tank bottom every morning from day 2 until day 21

5) Change 30% of the water volume every morning from day 2 until day 14. Change 50-70% of the water from day 15 to day 21.

### Item Seven: Harvesting Milkfish Larvae

Milkfish larvae on day 21 are at about the same developmental stage as wild-caught fry and are ready to be harvested. The procedures for harvesting, estimating and packing larvae to be sold or transported for stocking in nursery ponds or tanks follow those practiced by prawn hatchery operators and fry gatherers and dealers.

1) Drain water in the rearing tank to about one foot deep.



- 2) Using a small basin, scoop larvae and transfer into a big plastic basin.
- 3) To estimate the number of harvestable larvae, count the larvae in a basin of known water volume. This serves as a standard on which all estimates are based. Distribute larvae evenly in other basins containing the same volume of seawater as the standard basin. Compare visually whether the other basins contain more or less the same number of larvae as for the standard basin.
- 4) Pack larvae in double-layered oxygenated plastic bags containing 8-15 liters of seawater at a loading rate of 300 larvae/liter.

Source: **Milkfish Hatchery Operations** by R.S.J. Gapasin and C.L. Marte. Aquaculture Extension Manual No. 17, SEAFDEC Aquaculture Department, Tigbauan, Iloilo, Philippines, May 1990.

## ECONOMICALLY IMPORTANT SEAWEEDS OF PANAY ISLAND

Scientific name	Local name	Uses
<i>Acanthophora spicifera</i>		Human food, growth regulator
<i>Chondria armata</i>		Medicine (vermifuge and antibacterial)
<i>Eucheuma arnoldii</i>	guso	Source of carrageenan
<i>E. cottonii</i>	guso	Human food, source of carrageenan
<i>E. denticulatum</i>	guso	Human food, source of carrageenan
<i>E. striatum</i>	guso	Human food, source of carrageenan
<i>Galaxaura oblongata</i>		Source of sulfated sugar
<i>Gelidiella acerosa</i>		Human food, source of agar
<i>Gelidiopsis intricata</i>		Human food
<i>Gracilaria arcuata</i>	gulaman	Human food, source of carrageenan
<i>G. blodgettii</i>	gulaman	Human food, source of agar
<i>G. coronopifolia</i>	gulaman	Human food, source of carrageenan
<i>G. euchemoides</i>	cawat-cawat	Human food, source of carrageenan
<i>G. salicornia</i>	lagot	Human food, source of carrageenan
<i>Gracilaria</i> sp.	gulaman	Human food, source of agar
<i>Halymenia durvillaei</i>		Human food, source of carrageenan
<i>Hypnea cervicornis</i>	sumon-sumon	Human food, source of carrageenan
<i>H. esperi</i>		Human food, source of carrageenan
<i>H. pannosa</i>		Human food, source of carrageenan
<i>H. valentiae</i>		Human food, source of carrageenan
<i>Laurencia cartilaginea</i>	lagot-laki	
<i>L. flexilis</i>		Source of agar
<i>L. obtusa</i>		Human food, medicine (vermifuge and antibacterial), source of amino acids
<i>L. papillosa</i>		Human food, medicine (vermifuge and antibacterial), source of agar
<i>Scinaia moniliformis</i>		Human food

Source: List of Panay Seaweeds, Seaweeds Project. SEAFDEC Aquaculture Department, Tigbauan, Iloilo, Philippines.