

1989

# Fishery resources: Problems, rehabilitation, and development

Aquaculture Department, Southeast Asian Fisheries Development Center

---

Southeast Asian Fisheries Development Center, Aquaculture Department (1989). Fishery resources: Problems, rehabilitation, and development. Aqua Farm News, 7(2), 1-13.

---

<http://hdl.handle.net/10862/2663>

---

*Downloaded from <http://repository.seafdec.org.ph>, SEAFDEC/AQD's Institutional Repository*

## **FISHERY RESOURCES: PROBLEMS, REHABILITATION, AND DEVELOPMENT**

### **Item One: Fish Conservation Decalogue**

I. Conserve and protect our fishery resources for the prosperity of our country and people.

II. Desist from using explosives and poisons in fishing; this illegal practice depletes the fish population of our seas, lakes, and rivers.

III. Refrain from catching fish with dredges and fine-meshed nets; these devices catch young and premature fish.

IV. Do not dump into catching grounds petroleum, acid, coal, oil, tar, and other industrial wastes; these substances are deleterious to fish or aquatic life.

V. Do not catch fry and undersized fish nor gather fish eggs for consumption; allow them to grow and breed more fish.

VI. Observe the "close season" regulations for specified fishing grounds promulgated to conserve the fisheries in such fishing grounds.

VII. Do not block fishways by barriers and other fishing gears; allow the migration of fish into spawning grounds.

VIII. Refrain from catching the "sabalo" or mother milkfish; this is the only source of bangus fry for fishponds.

IX. Do not catch fry or fish eggs in fishery reserves, fish refuges and sanctuaries; this prohibition is intended to conserve our fishery resources.

X. Obey all fishery laws, rules and regulations; they are the means of implementing the policy of fish conservation.

Source: Bureau of Fisheries and Aquatic Resources (BFAR).

### **Item Two: Constitutional Provisions**

The New Constitution of the Republic of the Philippines recognizes the responsibility of the State not only to manage, develop and conserve the fishery/ aquatic resources but also to protect the rights of its citizens in the proper utilization of the same, as follows:

Article XII, Section 2 -- "The State shall protect the nation's marine wealth in its archipelagic waters, territorial sea, and exclusive economic zone, and reserve its use and employment exclusively to Filipino citizens."

Article XIII, Section 7 -- "The State shall protect the rights of subsistence fishermen, especially of local communities, to the preferential use of the communal marine and fishing resources, both inland and offshore. It shall provide support to such fishermen through appropriate technology and research, adequate financial production and marketing assistance and other services. The state shall also protect, develop and conserve such resources. The protection shall extend to offshore fishing grounds of subsistence fishermen against foreign intrusion. Fishworkers shall receive a just share from their labor in the utilization of marine and fishing resources."

**Item Three: All about Illegal Fishing**

Q. What is illegal fishing?

A. Illegal fishing is fishing with the use of destructive materials and substances such as dynamite or its derivatives, obnoxious or poisonous substances, electric currents, or the use of fishing gear prohibited by existing fishery laws, rules and regulations.

Q. What are the most destructive forms of illegal fishing?

- A. 1) Fishing with the use of explosives.  
2) Fishing with the use of obnoxious or poisonous substances.

Q. What is fishing with the use of explosives?

A. It means the use of dynamite, other explosives, or chemical compounds that contain combustible elements or ingredients that, upon ignition by friction, concussion, percussion, or detonation of all or parts of the compound, kill, stupefy, disable or render unconscious any fish or fishery and aquatic product. It also refers to the use of any other substance or device that causes explosion capable of producing the said harmful effects on fish or fishery and aquatic products.

Q. What are the components of dynamite?

A. Blasting cap, fuse, and sodium nitrate powder.

Q. What are the adverse effects of the use of explosives in fishing?

A. Destruction of the fishery resources where fish and other fishery aquatic products spawn and grow, and death or disability of big or small fish and other aquatic organisms.

Q. What is fishing with the use of obnoxious or poisonous substances?

A. It means catching fish with the use of substances, plants and extract or juice thereof, and chemicals, whether in raw or processed form, harmful or harmless to human beings, which kill, stupefy, disable or render unconscious fish or fishery and aquatic products.

Q. What are the adverse effects of the use of poisonous or obnoxious substances in fishing?

A. Destruction of the habitat of fish and death, stupefaction, disabling or rendering unconscious fish and other aquatic animals.

Q. What is electro-fishing?

A. It is fishing with a device using electricity generated by dry-cell batteries, electric generators, or other sources of electric power to kill, stupefy, disable or render unconscious fish or other fishery and aquatic products.

Q. What are the adverse effects of electro-fishing and where is it mostly operated?

A. Death or dismemberment or both of human beings and destruction to property, especially if the electric current is tapped from power lines. It also kills, stuns, or renders unconscious fish which are mostly big and mature. It is operated mostly in fresh rather than marine waters because in the latter electric current is more diffused.

Q. Is dealing with illegally caught fish or fishery and aquatic products prohibited? What does "dealing" mean?

A. Yes, it is prohibited under Section 33 of P.D. No. 704, as amended, and punishable by imprisonment for 5-10 years under Section 3 of P.D. No. 1038. "Dealing" refers

to selling of fish illegally caught through the use of explosives and poisonous or obnoxious substances.

- Q. Is mere possession of explosives intended for illegal fishing prohibited?
- A. Yes, illegal possession of explosives is prohibited under Section 1 of P.D. No. 1058.
- Q. What is the penalty for mere possession of explosives intended for illegal fishing?
- A. Imprisonment ranging from 12 to 25 years.
- Q. What is the penalty for fishing with the use of explosives?
- A. Imprisonment ranging from 25 years to life imprisonment if explosives are actually used, provided, that if the use of explosives results in:
- 1) physical injury to any person, the penalty shall be imprisonment ranging from 15 years to life imprisonment; or
  - 2) loss of human life, the penalty shall be life imprisonment or death.
- Q. What is the penalty for fishing with the use of obnoxious or poisonous substances?
- A. Imprisonment ranging from 8 to 10 years, provided that if the use of such substance results in:
- 1) physical injury to any person, the penalty shall be imprisonment from 10 to 12 years; or
  - 2) loss of human life, the penalty shall be imprisonment from 20 years to life, or death.
- Q. What is the penalty for electro-fishing?
- A. Imprisonment ranging from 2 to 4 years.
- Q. What are fine-meshed nets?
- A. They are nets used in fishing or intended for fishing with mesh size less than 3 centimeters measured between two (2) opposite knots of a full mesh when stretched.
- Q. Is it unlawful to fish with the use of fine-meshed net?
- A. Yes, under certain exceptions, it is unlawful for any person, association, or corporation to fish in any fishing area in the Philippines with the use of fine-meshed nets and sinamay cloth at the bunt or bag of any fishing gear.
- Q. What are the exceptions to the use of fine-meshed nets?
- A. They may be used in catching *ipon*, *padas*, *bingus* fry, marine aquarium commercial fishes and such species which by their very nature are small but already mature such as, but not limited to, *alamang*, *tabios*, *dulong*, *sinamoan*, *dilis*, *hipon*, *taguntong*, and snails.
- Q. What is the penalty for fishing with the use of fine-meshed nets?
- A. A fine of not less than P500.00 but not more than P5,000.00 or imprisonment for not less than 6 months to 4 years, or both such fine and imprisonment, in the discretion of the court: Provided, however, that the Director of Fisheries and Aquatic Resources is hereby empowered to impose upon the offender an administrative fine of not more than P5,000.00, including the confiscation of the fishery nets and paraphernalia and the fish catch.
- Q. What is a trawl?
- A. It is a fishing gear made of net in the form of conical bag with the mouth kept open by various devices with the entire gear towed, trailed or trawled, usually at the bottom of the sea to capture bottom dwelling species.

Q. How are trawls classified?

- A. 1) Commercial trawl - operated by using a boat more than 3 gross tons.  
2) Baby trawl - operated in a vessel 3 gross tons or less. Not more than 3 persons are need in its operation.

Q. Where may commercial trawls be operated?

- A. Commercial trawls may be operated in Philippine waters beyond 7 kilometers from the shorelines of all provinces of the Philippines.

Q. What is the penalty for trawl fishing in Philippine waters within 7 kilometers or less from the shorelines?

- A. Imprisonment ranging from 6 months to 6 years as provided under Section 4 (b) of P.D. 1058.

Q. Why do fishermen/some parties oppose the use of trawl? Is trawl destructive?

- A. Because trawl is an active/mobile or dynamic fishing gear that catches faster and more in a relatively short time, it becomes an object of envy by other fishermen whose catch is low and small in volume since they operate passive gears. Trawl is destructive if operated in shallow areas which are usually the breeding and nursery grounds of fishes; likewise, the massive scraping action sweeps away algae or attached/sedentary plants which are the sanctuaries/refuge of fishes.

Q. What other fishing methods are considered illegal?

- A. 1) "Paantukos" is operated with the use of lighted torches (waswas) and or use of kerosene, crude oil, gasoline, or any other flammable substances poured on any water area and ignited to scare or drive fish towards the said gear.  
2) "Hulbot-hulbot" is operated with the use of a fishing gear consisting of a conical shaped net with a pair of wings, the ends of which are connected to two ropes with buri, plastic strips or any similar materials to serve as scaring/herding device with hauling ropes passing through a metallic ring permanently attached to a tom weight (linggote) when hauled into a fishing boat.  
3) "Kayakas" is usually operated in shallow waters and the weights attached to the scareline may hit and break the soft and brittle corals.

Q. Who are deputized to enforce fishery laws, rules and regulations?

- A. Members of the Philippine Coast Guard, the Philippine Constabulary, the local police forces, government law enforcement agencies and other competent government employees duly designated in writing by the Department of Agriculture are made deputies of said Secretary in the enforcement of all fishery laws, rules and regulations.

Q. Who are qualified to be deputized as Fish Wardens to enforce fishery laws, rules and regulations?

- A. Municipal mayors, barangay captains and officers of registered fishermen's associations.

Q. What compose the legal basis that justify the deputation of competent government officials, barangay officials and officers of a registered fishermen's association?

- A. 1) Section 40 of PD 764, as amended  
2) Letter of Instructions No. 550  
3) Letter of Instructions No. 929

Q. What can ordinary persons do to help stop or minimize illegal fishing?

- A. 1) Inform authorities concerned of all persons engaged in illegal fishing practices in their locality.
- 2) Support the government in its campaign against all forms of illegal fishing through information dissemination within their family/neighborhood/community on the hazards and adverse effects of illegal fishing.

Source: **Primer on Illegal Fishing**, Bureau of Fisheries and Aquatic Resources, Quezon City, October 1988.

#### **Item Four: "War" Against Illegal Fishing**

The Department of Agriculture (DA) recently declared "war" against illegal and destructive fishing practices particularly in Palawan, the Visayan Sea, Manila Bay, Lingayen Gulf, Pangul Bay, San Miguel Bay, and Lamon Bay.

As part of the anti-illegal fishing campaign, the DA has created its own task force on illegal fishing. In just over two years, the task force confiscated over 83 metric tons of fish worth nearly 1.7 million pesos, confiscated and impounded four fishing vessels, and apprehended close to 200 persons.

The DA has also launched a program that would teach alternative fishing techniques to fishermen who resort to destructive fishing. For example, there is a pilot-tested program that seeks to convince fish-poisoning practitioners to use nets instead.

Cyanide poisons not only the fingerlings and fry but also coral reefs. And if a coral reef is destroyed either through blast fishing or cyanide poisoning, it takes 50 years for it to fully recover.

To strengthen law enforcement, the DA has released 1.36 million pesos to buy pumpboats for use in the anti-illegal fishing drive in 17 selected provinces in the country. Hundreds of barangay captains have been deputized as fishery wardens, and bancas for patrol purposes have been donated to coastal municipalities.

The creation of a Presidential Action Committee against destructive fishing is envisioned, in coordination with the Departments of Environment and Natural Resources, National Defense, Local Governments, Justice, Education, and Tourism. This larger task force is hoped to pave the way for a community-based coastal and marine resources management and conservation program. The private sector should be involved in this campaign. The government alone cannot achieve anything without the full, unconditional and absolute support of the private sector.

What we strive to protect is not only the fishing ecosystem, but also sustainable productivity and profitability for our fishermen today and in the future.

Source: Speech of DA Sec. Carlos G. Dominguez, delivered by DA Reg. Dir. Emigdio L. Fabella at the Symposium on Coastal Waters Rehabilitation and Development and Seminar-Workshop on Fishery Law Enforcement, Iloilo City, March 9-11, 1989.

## Item Five: Fishes Commonly Caught with the Use of Explosives

Scientific Name	English Name	Vernacular Name (Tag.)
<i>Acanthurus bleekeri</i>	blue-lined surgeon fish	labahita
<i>Caesio caeruleaureus</i>	black-tailed caesio	dalagang-bukid
<i>Caesio chrysozonous</i>	golden caesio	dalagang-bukid
<i>Caesio cuning</i>	denticulated caesio	dalagang-bukid
<i>Caesio lunaris</i>	plump caesio	dalagang-bukid
<i>Caranx armatus</i>	long-finned cavalla	talakitok
<i>Caranx crumenophthalmus</i>	big-eyed scad	matang-baka
<i>Caranx djedaba</i>	even-bellied crevalle	salay-salay lalake
<i>Cybium commerson</i>	Spanish mackerel	tangigi
<i>Elagatis hipinnulatus</i>	two-finned runner	salmon
<i>Kyphosus lembus</i>	striped rudder fish	ilak
<i>Lutianus malabaricus</i>	Malabar red snapper	maya-maya
<i>Megalaspis cordyla</i>	hardtail	oriles
<i>Mugil caeruleomaculatus</i>	long-finned mullet	banak
<i>Mugil melinopterus</i>	black-finned mullet	talilong
<i>Rastrelliger brachyosomous</i>	short-bodied mackerel	hasa-hasa
<i>Rastrelliger chrysozonous</i>	striped mackerel	alumahan
<i>Sardinella perforata</i>	deep-bodied herring	lapad
<i>Scatophagus argus</i>	common spadefish	kitang
<i>Sphyaena jello</i>	banded barracuda	asogon
<i>Sphyaena obtusata</i>	striped barracuda	torsilyo
<i>Stolephorus commersonii</i>	long-jawed anchovy	dilis
<i>Stolephorus indicus</i>	Indian anchovy	tuakang
<i>Tenthis javus</i>	Javan siganid	samaral
<i>Therapon jarbua</i>	convex-lined theraponid	bagaong
<i>Upeneoides sulphureus</i>	yellow-striped goatfish	saramulyete

Source: Primer on Illegal Fishing, Bureau of Fisheries and Aquatic Resources, Quezon City, October 1988.

## Item Six: How to Distinguish Normally Caught from Dynamited Fish

Body Parts	Normally caught fish	Dynamited Fish
<u>External</u>		
Eyes	Bright and clear	Reddened due to ruptured capillaries
Scales	Intact	Loose at mid portion of body length
Epidermis (skin)	Normal in appearance	Signs of blood effusion at base of the fins, abdomi-

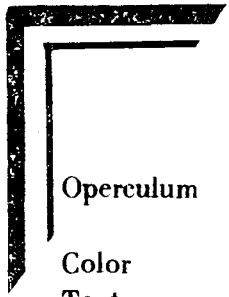

Operculum	Normal	nal area and around the vent Blood oozing from gill cover
Color	Bright	Dull
Texture	Stiff	Soft

Internal

Air Bladder	Normally situated and inflated with air	Ruptured and filled with blood
Internal organs	Situated in natural locations	Crushed and mixed with blood particles
Vertebral column	Normal	Broken and stained with blood
Flesh	Translucent	Reddish brown
Spinal blood	Normal	Ruptured causing internal hemorrhage of various degrees
Abdominal ribs	Normally situated	Fractured and deeply stained with blood
Body cavity	Normal	Filled with blood particles

Radiograph (X-Ray Diagnosis)

Air bladder	Normally situated	Obliterated
Vertebral column	"	Broken
Abdominal ribs	"	Fractured
Internal organs	"	Displaced from their natural locations

Source: "Different Illegal Fishing Practices and its Harmful Effects," by Romeo de Sagun, Chief Legal Officer, BFAR, 1989.

**Item Seven: Facts about Philippine Coral Reefs, Mangroves, and Sea Grass Beds**

**I. IMPORTANCE**

**Coral Reefs**

- Coral reefs are one of the world's most productive marine ecosystems.
- Coral, a living animal, is the foundation of the coral reef ecosystem.
- There are 27,000 square kilometers of Philippine coral reef areas.
- About 15% of the total finfish production in the Philippines are from coral reefs.
- Major commercial pelagic and large demersal species are partially dependent on reefs.

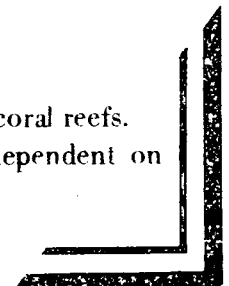



- Coral reefs serve as habitat and feeding, spawning and nursery ground, and provide shoreline protection.
- Sea cucumber, lobster, aquarium fish, shell, and seaweed industries are reef-related.
- Small fishermen depend heavily on reef ecosystems.

### **Mangroves**

- Mangrove swamps, like coral reefs, are very important marine ecosystems.
- They serve as a food-rich breeding and nursery ground for fishes and other marine life.
- They provide organic nutrients which are necessary for nearby marine habitat.
- They provide shoreline protection from tidal waves and typhoons, promote natural land reclamation, and replenish oxygen in the air.

### **Sea grass Beds**

- Sea grass beds serve as breeding, nursery, and feeding habitat for many important fish and invertebrates.
- Siganids, groupers, mullets, milkfish fry, marine turtles, and sea cows are highly dependent on sea grass beds which make the latter a critical part of the coastal ecosystem.

## **II. STATUS**

### **Coral Reefs**

- About 70% of Philippine coral reefs are heavily damaged and as a consequence their productivity has been seriously reduced.
- Only 5.5% of the total reef area are in excellent condition (1981).
- About 24% are in good condition.
- Major causes of reef degradation are: a. dynamite fishing, muro-ami, kayakas, and poisoning; b. siltation due to poor land use and deforestation; and c. coral gathering for construction and ornamental purposes.

### **Mangroves**

- In 1920, total Philippine mangrove area was estimated at 500,000 hectares. In 1980, only 29% (146,000 hectares) remain vegetated.
- The attrition is due to the construction of 23,000 ha. of legal and illegal fishponds and to losses due to reclamation, salt beds, and indiscriminate cutting.

### **Sea grass Beds**

- About one-third of the country's sea grass beds had been destroyed.
- Destruction is attributed to siltation, destructive fishing, reclamation, and pollution.

The destruction of very large tracts of these ecosystems has resulted in the further decrease of fishery products and resources.

Source: Task Force Report on Coastal Marine Resource during the National Policy and Planning Seminar-Workshop, Baguio City, 1987.

#### **Item Eight: Urgent—Reef Conservation**

The most important product of coral reef is fish, estimated at about 30 tons per sq km per year for good reefs. One can have an idea of the potential fishery production of coral reefs by multiplying this figure by 30,000 sq km total coral reef area of the Philippines. It is estimated that 20-25% of fish caught from marine waters comes from coral reefs. The value of this production runs into billions of pesos which is not realized at present because of the widespread destruction of our reefs. About 70% of our reef system is in various stages of degradation. Hence, the urgent need to manage and conserve coral reefs.

Considering our increasing population which must be fed, all forces should be mobilized to protect the remaining good reefs in the country and to rehabilitate the ones that have been devastated. Many agencies, both government and private, now have programs to manage coral reefs. PCAMRD has embarked on a nationwide coral reef management program beginning this year. Haribon Foundation has also such a program. EMB has a rehabilitation program for coral reefs. But these are not enough, considering the extent of the problem and the many roadblocks to implementation of conservation programs. Local and regional agencies have to be involved. In many ways they can be more effective as they are directly in touch with the users (and destroyers?) of coral reef resources.

Conservation and livelihood activities should go hand in hand. The idea of no-touch park system is no longer applicable to our situation. The system that has a greater probability of success is a multipurpose system. In other words, a park system incorporates areas where people are permitted to extract products for their livelihood and those which serve as fishery replenishment areas or sanctuaries.

Although artificial reefs can result in the production of fish, they should not be understood as the complete answer to the problem of fishery depletion and destruction of natural reefs. Rather, they should be considered as a scheme to lighten the fishing pressure on natural reefs and to concentrate fish for easier fishing. Artificial reefs cannot stand alone without the natural reefs (coral reefs) and other natural fishery habitats, such as beds of sea grasses and mangroves, all of which serve as sources of juveniles that colonize the artificial reefs. Artificial reefs are essentially fish-attracting devices. They cannot replace natural reefs. They should be constructed to alleviate human pressure on the natural reefs. That is why, protection of natural environments is necessary if an artificial reef program is to succeed.

Source: Dr. Angel A. Alcala, "Management of Coral Reefs," paper presented at the Regional Symposium on Coastal Waters Rehabilitation and Development, Iloilo City, March 9, 1989.

#### **Item Nine: Coastal Enhancement by Artificial Reefs**

News stories give the impression that man-made reefs will substitute for destroyed coral reefs and will immediately generate a bountiful fish population.

In this connection, the three recognized functions of artificial reefs should be noted: (1) as a fish-aggregating device that concentrates fishes for easier fishing, (2) as protection or shelter for fish juveniles preventing their early harvest, and (3) to increase coastal productivity in the long run by providing substrates for growth of sessile organisms and establishment of new food chains. They may also function as effective barriers to poaching trawlers or other intruders in coastal fishing grounds.

Function No. 1, or *fish attraction*, can lead to overfishing, if not regulated. This can happen even if there is a steady source of fish recruits from nearby coral reefs. In developed countries where fish stocks are not overexploited and fishery laws are strictly enforced, artificial reefs serve as fish-aggregating devices that reduce the cost of fishing. In the Philippines, however, both these fishing conditions do not exist.

Function No. 2, or *protection*, is ideal on condition that fish juveniles from nurseries are released to stock coastal waters. Without this requirement, the protective function of artificial reefs will not by itself result in increased fish stocks. There is yet no evidence that placement alone of artificial reefs results in increased fish production.

The third function, *increasing the productivity* is the most important for our fishery resources. Together with the release of fish juveniles and their protection, the productivity-enhancing function of artificial reefs with established coral community will result in new fish biomass and a real increase in fish production.

One study gives an estimate of 10 years for coral communities to develop on used tire substrates when properly anchored and sited. Another study shows that coral growth is faster on concrete than on tire modules.

The extended time frame for building a coral community is worth the wait because coral reefs can support a standing crop of up to two tons of fish per hectare per year. Thus, if only the Philippines' 3 million hectares of coral reefs were intact today, they would be capable of producing 900,000 tons of fish a year, or nearly half the present total fish production.

Something should also be said about artificial reefs made of bamboos or scrap tires. They are no doubt cheap, easily assembled devices, and the most practical under the country's economic conditions, if the intention is to concentrate fishes for easier fishing. However, our coastal waters are already overfished. Moreover, the bamboo and tire modules are unstable for coral growth and therefore cannot function in increasing coastal productivity. These modules are also not very effective barriers to the entry of large trawlers into municipal waters.

For these and other reasons, a 1988 review of artificial reefs in Japan - a country with over 200 years of experience with artificial reefs - recommends that the use of tires and other scrap materials be forbidden. The tire or bamboo module is, at best, a temporary home for growing fishes (Function No.2). At worst, it will only further encourage overfishing, and thus the initial increased catch (Function No.1) cannot be sustained. So we end up with a worse fish stock situation.

With the country's present condition of a degraded and overfished coastal environment, we need the artificial reef for enhancing coastal productivity. For this purpose concrete material is so far the best choice. When properly designed and deployed, the concrete modules serve as permanent foundation for coral growth. They will accelerate

the formation of large coral reefs which normally take hundreds or even thousands of years. The artificial reef ultimately forms part of naturally growing coral reefs. Only then will the reef truly play a significant role in enhancing coastal productivity.

An inhibiting factor is, of course, the cost of concrete reefs. However, once all the costs and benefits are identified and considered over the expected life span of the reef this factor will not be as restrictive as it may appear. Artificial reef experts have recognized that in the long run, it is more economical to build artificial reefs of durable materials.

Source: "Countryside Development Through Small-scale Fisheries." paper presented by Dr. F.J. Lacanilao, SEAFDEC AQD Chief, at the Regional Symposium on Coastal Waters Rehabilitation and Development, Iloilo City, March 9, 1989.

dice block

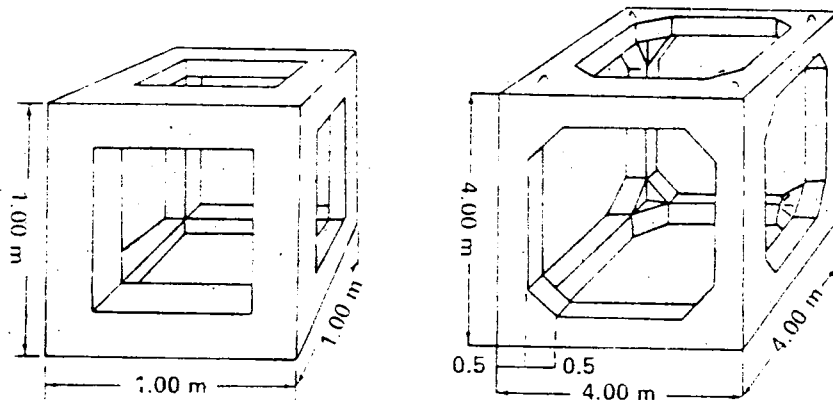

tube block

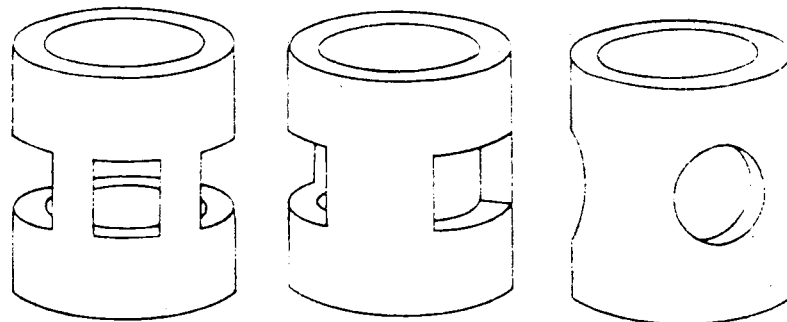

Artificial reefs: concrete modules. Source: "Fishes, Sunken Ships and Artificial Reefs" In: SEAFDEC Newsletter, Vol. 10, No.3, 1987, Bangkok, Thailand.

### **Item Ten: On Target: Countryside Fishery Development**

During the last two years, GNP figures show the growth of our country's economy to an impressive average rate of 5.9%. However, only a small portion of the benefits appears to have trickled down to the masses. In our midst, poverty, unemployment, and other social inequities are still endemic and have in fact increased. A redirection of government plans and policies is therefore necessary, if not already on stream. The main thrust of this effort is countryside development.

In improving the social and economic condition of our rural population, the plight of the municipal or small-scale fishermen deserves more serious attention. They provide half of the national fish production, yet together with the mountain dwellers, the landless farmers, and the urban poor, small fishermen are the poorest of the poor in our society. Their predicament is largely the result of unsolved problems in resource management as follows: (1) overexploitation of the coastal fishery resources, (2) destruction of fish habitats, (3) inefficient enforcement of fishery laws, (4) lack of alternative job opportunities for the small fishermen, and (5) population pressure.

These problems demand viable innovative solutions. Here worthy of serious consideration is the proposed three-pronged approach to small-scale fisheries development. It is a concept that integrates three complementary programs to be carried out nationwide, namely: mariculture or seafarming, construction of concrete artificial reefs, and grant of territorial use rights to small fishermen's associations or cooperatives.

Benefits of this integrated scheme for management and conservation of our coastal resources include the following: (1) replenishment of the coastal fish stock that would increase it to a sustainable level; (2) restoration of the environmental and ecological integrity of the coastal ecosystems, i.e., coral reefs and mangroves; (3) increased employment and income for municipal fishermen; and (4) effective enforcement of fishery rules and regulations that shall, among others, put a stop to illegal fishing methods and harmful encroachment of commercial fishing vessels into municipal waters.

The role of fishermen's associations or cooperatives, under the policy of granting them exclusive territorial use or fishing rights, is emphasized. It is vital because if the small fishermen themselves are not able to effectively regulate and protect their interests, the whole coastal fishery development program will be a failure as past experience has shown. In other words, the three components of the program must be perceived and implemented as an interconnected management approach.

This is not to underplay the function of the deep-sea fishing industry as it has to maintain its major share in the national fish production in order to meet the demand of our growing population. Let it be pointed out, however, that in neglecting the problems of the small municipal fishermen, negative consequences could result. These include the continuing ruin of our coastal resources, migration of the impoverished fisherfolk to already congested urban centers in search of a better life, and social unrest from dissatisfaction with government policies that could drive them right into the hands of radical elements.

Source: "Countryside Development Through Small-scale Fisheries: Seafarming and

Territorial Use Rights," paper presented by Dr. F.J. Lacañilao, SEAFDEC AQD Chief, at the Regional Symposium on Coastal Waters Rehabilitation and Development, Iloilo City, March 9, 1989.

### NURSERY PONDS IN PRAWN FARMING

There are at least three important advantages in the use of nursery ponds on a prawn farm:

- 1) They permit the farmer to maintain intensive control over the young prawn seed during their early, and most vulnerable, weeks of life.
- 2) Nursery ponds make more effective use of pond area by always keeping prawns at high densities.
- 3) They shorten the time that prawns are in the fattening ponds which permits the ponds to be used for multiple harvests each year.

#### **Advantages**

The first advantage, intensive care, can result in higher overall survival rates. Most of the non-crisis prawn mortality in aquaculture is thought to occur during the first six weeks after stocking. It is hard to tell since even 200,000 juvenile prawns, each only 20 mm long, could be needles in the haystack of a one-hectare pond. In a small nursery pond of only a few hundred meters, predation and competition can be minimized while feed availability and water quality are maximized.

After about six or eight weeks, especially in new ponds or those managed by inexperienced prawn farmers, one often encounters an environmental crisis. This might be caused by overfeeding or overfertilization and is often characterized by low oxygen "event" where some prawns are lost, or by an algae bloom that gets out of hand. The growth rate of the prawns slows down, perhaps due to a spoiled pond bottom or chronic oxygen depletion or high acidity and the consequent loss of natural feed. If at this point the farmer could transfer his prawns into a new pond, growth rate would increase like magic.

This is the magic of a nursery pond. After six or eight weeks of intensive care the prawns are drained out of the nursery into a new fresh (or newly freshened) pasture. Whether it is the new source of natural feed, or the larger area of foraging, or the clean pond bottom with more oxygen, the transfer does indeed perform magic for prawn growth rates. You could transfer the prawns every four to six months and increase sizes per harvest and harvests per annum.

The problem might be costs: the expense of building small ponds and water control structures, and maintaining them, managing water in many small ponds, and the cost of labor to manage and feed many small ponds. On the other hand, the advantages of improved growth and survival rates, more efficient use of pond areas, and the multiple harvests could make it all worthwhile. Each farmer will have to work it out for his own needs.