

# Prawn Industry Development in the Philippines

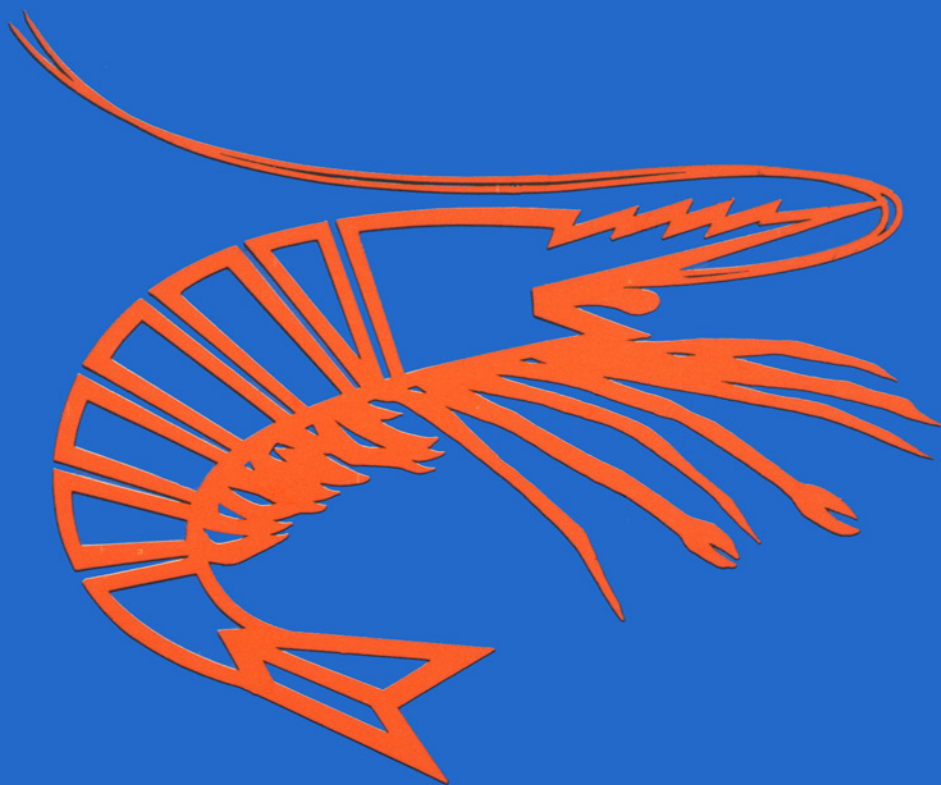

Aquaculture Department  
Southeast Asian Fisheries Development Center  
1984



# **Prawn Industry Development in the Philippines**

PROCEEDINGS OF THE NATIONAL PRAWN INDUSTRY  
DEVELOPMENT WORKSHOP

10-13 APRIL 1984, ILOILO CITY, PHILIPPINES

Sponsored by Aquaculture Department of the Southeast Asian  
Fisheries Development Center, Bureau of Fisheries & Aquatic  
Resources, Ministry of Natural Resources, in cooperation with  
the Philippine Federation of Aquaculturists, Inc.

The Southeast Asian Fisheries Development Center (SEAFDEC) is an international research organization devoted to the development of aquaculture in the region - under an agreement among Japan, Malaysia, the Philippines, Singapore, Thailand, and Vietnam. SEAFDEC has three departments, namely; the Training Department in Bangkok, Thailand; the Marine Fisheries Research Department in Changi Point, Singapore; and the Aquaculture Department in Tigbauan, Iloilo, Philippines. The Aquaculture Department operates three major stations: the Main Station in Tigbauan, Iloilo; the Brackishwater Station in Leganes, Iloilo; and the Freshwater Station in Binangonan, Metro Manila.

Southeast Asian Fisheries Development Center, Aquaculture Department.

Postal Address: P.O. Box 256, Iloilo City, Philippines

Head Office: Tigbauan, Iloilo, Philippines

Liaison Office: Suite 901, State Financing Center

Ortigas Avenue, Mandaluyong

Metro Manila, Philippines

# TABLE OF CONTENTS

<b>INTRODUCTION</b> . . . . .	1
<b>OVERVIEW OF THE INDUSTRY</b> . . . . .	3
Seed Production . . . . .	3
Feed Development . . . . .	7
Pond Culture . . . . .	9
Processing and Marketing . . . . .	13
Policies/Financing . . . . .	16
<b>PARTICIPANTS, OBSERVERS AND GUESTS</b> . . . . .	19
<b>REVIEW PAPERS</b>	
Seed Production and the Prawn Industry of the Philippines . . . . .	33
Extensive and Semi-Intensive Culture of Sugpo in the Philippines . . . . .	55
States of Prawn Feed Development in the Philippines . . . . .	75
The Processing and Exporting of Prawns in the Philippines . . . . .	83
Government Policies on Aquaculture . . . . .	89



# INTRODUCTION

At the arrangement and sponsorship of the SEAFDEC Aquaculture Department and the Ministry of Natural Resources, with the cooperation of the Philippine Federation of Aquaculturists, Inc., the National Prawn Industry Development Workshop was held in Iloilo City on 10-13 April 1984.

The objectives of the Workshop were: to assess the status of the prawn/shrimp industry in the country, particularly in the areas of broodstock, hatchery and nursery, pond culture, processing, marketing, and financing; discuss current problems including technical gaps, extension services and financial constraints and chart future research & development directions accordingly; and bring together researchers, extension workers, hatchery, nursery, and farm operators, policy makers and workers from the research, government and private sectors so that the goals of the industry as a whole, rather than its individual components, could be defined.

Some 165 technologists, fishfarmers, government policy makers, managers, extension workers, teachers, and businessmen from various parts of the country and 90 researchers of the Aquaculture Department participated in the Workshop.

The Workshop, held at Sarabia Manor Hotel, was opened at 1000 hrs. on 10 April. In the keynote address, Hon. Manuel S. Alba, Minister of the Budget, commended the SEAFDEC Aquaculture Department for having generated essential research findings and developed technologies that are now being utilized by the industry. He cited the researchers for their work in the generation and verification of prawn culture technology, and to the training and extension workers for their efforts in packaging and disseminating the technology.

Minister Alba who hails from the aquaculture-rich province of Iloilo commended other research institutions and private corporations for their pioneering efforts and contributions to the growth of the industry. He urged the private sector and the various institutions to cooperate more closely for the benefit of the industry and assured that the Government will fully support the development of the prawn industry in the country.

At the closing activities on 13 April, AQD Deputy Chief Dr. Y. Taki presented one major problem he said he felt was not thoroughly discussed: the determination of mode of prawn culture. He reviewed three related premises in this regard, namely; biological, economic and historical and urged the workshop participants especially the researchers and aquaculturists to find solutions to this problem.

The message of Deputy Minister for Natural Resources Arnold B. Caoili recommended that existing institutional support, particularly financing, marketing and extension service, be thoroughly evaluated and asked for a more active participation from all sectors of the industry.

Philippine Federation of Aquaculturists President Ruperto Angudong, Jr. speaking on behalf of the private sector, agreed with the recommendation to lift the tariff on the importation of good quality feeds. Mr. Angudong encouraged the private sector to get organized in seeking incentives from the government and proposed the extension of the aquaculture loan for Panay Island to the other provinces of the country.

AQD Chief Dr. Alfredo C. Santiago, Jr. asked for the full cooperation and support of the private sector especially in the verification of the research results of the Department.

The Workshop was timely because prawn culture has emerged as a lucrative industry even as prawn research has intensified in the last ten years. Some 60 prawn hatcheries and more than a dozen nurseries have been established in the country while more fishfarmers are converting their milkfish ponds to prawn ponds. With these developments the Workshop organizers deemed it urgent to now assess the progress that has been made by the industry, ventilate problems, chart research and development directions, and define industry goals.



# OVERVIEW OF THE INDUSTRY

## Assessment and Recommendations

Five papers on five distinct components of the industry were presented by authorities on the field covered by the component. The areas reviewed are (1) seed production, (2) culture, (3) feed development, (4) processing and exporting, and (5) government policies. Presented below are the summaries and the recommendations that were generated from the papers and the discussions that followed.

## SEED PRODUCTION

The paper described the state-of-the-art in prawn hatchery technology and wild fry collection in the country. The major species for culture emphasized is *Penaeus monodon* Fabricius locally named as *pansat*, *lukon* or *sugpo*. It is currently the predominant species for pond culture and export. Technical and non-technical problems were brought up and possible solutions recommended. Also provided was an updated list of penaeid prawn hatcheries in the Philippines.

A brief assessment of the natural production cycles of sugpo as well as its artificial propagation provided background information on culture and production. The history and classification of existing hatcheries in the country were presented including primary considerations in establishing a hatchery. Part of the considerations are the technologies that have been generated by research institutions like the SEAFDEC Aquaculture Department and Mindanao State University Institute of Fisheries Research and Development and the private sector.

In the workshop session on seed production, problems that were identified were mainly on spawner supply, larval rearing, nursery, wild fry collection, transportation, and manpower shortage. Discussed were the following concerns:

### 1. Availability of wild spawners

Inquiry was made from private hatchery owners as to identification of the spawner sources. From ecological studies and from analysis of fishing trawl catches, some have already been identified in the Panay area, places like Miag-ao, Villa, Binun-an, Estancia and Concepcion in Iloilo, Casanayan

in Capiz, and Makato in Aklan. SEAFDEC has indirectly identified good collecting sites for spawners.

It was observed that there seem to be no spawners during particular months. The explanation was offered that perhaps no efforts are exerted to collect during certain periods for some reasons like inclement weather, although spawners may always be available.

A participant from San Miguel Corporation mentioned that spawner quality, not availability, is the problem. For certain months of the year, spawners lay high quality eggs with high survival rates, as experienced by many hatcheries in the Philippines. In other months, egg quality becomes so poor as to cause production to drop.

In the Southern Philippines Development Authority hatchery, collection of spawners has not been a problem. However, they collect only during full moon when they can be sure of catching good quality spawners.

The suggestion was to forge a good working relation between those in capture fisheries and the hatchery people. It was cited, for instance, that in Thailand spawners collected by fishermen are sold to hatcheries. Such cooperation could greatly benefit our own prawn industry. A few years back, trawlers stopped operating in the area so that this particular source for experiment broodstock has dried up.

The need was realized for data monitoring among hatcheries so that researchers and operators can share in the analysis and resolution of common problems.

Control of spawner movement should be done by licensing not by banning, because the latter does not seem to always work. Exporting spawners is a profitable enterprise. It is attractive, legal restrictions notwithstanding, for people to engage in it.

At present, there are two sources of spawner supply: wild and pond broodstock. Relying solely on wild supply does not solve the problem of unpredictability and inconsistency of supply. The use of pond-reared broodstock can be a solution. However, there is an age requirement for spawners—about 10 months old—which is not always readily satisfied by pond-reared sources. Moreover, hatchery operators tend to believe that quality of fry from pond-reared broodstock is poorer than that from wild spawners.

## **2. Pond-reared broodstock**

A participant from the San Miguel Corporation cited his experience with pond-reared broodstock: 30 g females were reared with commercial feeds in 1 m tanks; the good ones were selected and fed with clams and mussels until they reached 100 g. However, not much success was achieved using this approach.

At the Masaganang Sakahan, Inc. (MSI) project in Mindoro Occidental, they use broodstock tanks, similar to those of SEAFDEC, covered with black cloth. Females weighing 100 g and males weighing 60 g are selected, treated with 10-20 ppm tetracycline, and then ablated. Production average

is two (2) million nauplii per day.

### **3. Larval rearing**

Water quality in the hatchery changes with the season because certain species of diatoms are not produced throughout the year. However, it is possible to have pure cultures of diatom all-year round. With regards to other trace elements, some hatcheries use chelating agents to bind harmful ions in the water. The effects of heavy rain on algal cultures can be avoided by maintaining them indoors. The problem in hatchery may be related to spawner quality, not heavy metal contamination. It may be also related with shrimp or prawn quality because its occurrence appears to be countrywide. For example, whenever the SMC hatchery has a good production of postlarvae, catch of fry from the wild is also high.

A reservoir is helpful in the operation of a hatchery, it was emphasized. Bacterial content and variety are reduced in water that is stored over a longer period.

### **4. Feeding**

The SEAFDEC Aquaculture Department is at present conducting experiments using micro-encapsulated diets in feeding prawn larvae. Preliminary results suggest that the diet is more suited for *P. indicus* than for *P. monodon*. Further refinement is being made to suit the diet for *P. monodon*. A great possibility exists for these micro-encapsulated diets to take the place of algae. An ongoing experiment incorporates micro-encapsulated diets in *Artemia*.

### **5. Diseases**

The SEAFDEC Aquaculture Department is in the process of identifying the causes of different diseases of prawn larvae. Results of studies are being disseminated through publications and training programs.

### **6. Nursery**

At the Department, studies on the culture of postlarvae in nursery have been conducted. Pellets were fed to postlarvae at 10-20% biomass. However, this was found low for PL<sub>5</sub>. Therefore, 50% of the biomass as the maximum level was recommended. As the postlarvae grow the feeding rate should be correspondingly reduced.

The satiation method was also suggested to determine optimum feeding level. This is done by feeding about 10-20% biomass and then looking for leftovers after a few hours. Appropriate amounts may be added or decreased depending on whether or not there are leftover feeds.

The optimum stage at which postlarvae may be harvested from the nursery for stocking in ponds could be determined in terms of economics;

while postlarvae may have low survival in ponds they are cheaper. Thus, a trade-off should be established between survival and cost of production inputs in the pond.

Aside from concrete tanks, plastic-lined tanks can be used in hatcheries. Effectiveness of hapa nets for nursery has also been demonstrated, using a density of 20,000 - 30,000 in 10 m<sup>3</sup>, producing an approximate survival rate of about 70% from PL<sub>5</sub> to PL<sub>30</sub>.

## **7. Wild fry collection**

A training program on fry identification, collection, and transport is being conducted by the AQD. It was felt that definite figures on wild fry collection be made available to the private sector, including baseline data, to properly assess fry resources.

## **8. Transport and handling**

In general, method of transport depends on how long it takes to transport and the number of fry. The fry depends on oxygen dissolved in the water and the level should be kept above the minimum needed for survival. Reduction in temperature is beneficial because it lowers oxygen consumption due to lowering of metabolic rates.

The effectivity of transport and handling also depends on the schedule of commercial flights. Private planes may be convenient but the volume to be transported should be as large as possible to keep down unit cost.

## **9. Manpower**

It was generally felt that technicians who have the right attitude can manage hatcheries. Teamwork is the secret of a successful hatchery operation. The need to upgrade the competence of technicians from time to time through training programs was felt.

It was suggested that the private sector and the training institutions collaborate to institute a workable program designed to ensure the quality of hatchery technicians.

It was suggested that for technicians to develop a more positive attitude towards their work, better incentives should be given them like promotion, holidays with pay, transportation allowances and other fringe benefits.

Finally, the workshop distilled the recommendations into the following:

1. For research directions: studies be conducted on the husbandry of broodstock particularly on feeding management; substitutes for expensive feed items like *Artemia* and formulation of alternative feeds using sources which do not compete with human food supply.
2. For industry support: financial support be given by the private sector in collaboration with the fishfarmers by funding studies relevant to their own local conditions and/or done in their locality.

## FEED DEVELOPMENT

The paper gave an overview of the status of prawn feed development in the Philippines. Nutrient requirements, diet development, food and feeding habits, diet formulations for prawn (*P. monodon*) were discussed. Diets for prawn larvae and broodstock were also assessed.

The shift towards monoculture and a more intensive farming of prawns brought about by its high market price, increase in consumer demand, and availability of seeds have led to the demand for an external source of food for the various prawn stages. Due to the scarcity of hard data on *sugpo*, however, feed formulations are computed based on experience and work on other species. Available information on the nutritional requirements of *P. monodon* suggest the use of 35-40% protein, 10% fat, 20-30% carbohydrates and 1% cholesterol for grow-out formulations, while larval and broodstock diets still have to be developed. Nevertheless, recent studies indicate that certain nutrients in molluscs and fish are needed for gonad development and that polyunsaturated fatty acids like arachidonic acid, eicosapentanoic acid and docosahexaenoic acid, which are also present in molluscs and fish liver oils, are necessary for prawn maturation.

Prawns feed on slow-moving benthic organisms like crustaceans and molluscs. Their guts become empty four hours after feeding, thus, they must be fed twice or thrice a day after sunrise and before sunset. Since they are slow eaters, the diet must be stable in water for 3-6 hours. Use of finely ground feedstuff and a good binder, gelatinization of starch, and steaming of pellets have been found to give water-stable diets. Sago palm starch, corn starch and alpha potato at 5% level in the diet are considered acceptable binders. Diet attractants like earthworm are also necessary.

Several commercial feeds for prawn are now in the market but there is no ideal formulation as yet. There is much room for improvement on the diet formulations now available. Problems remain like the increasing cost of feedstuff, quality control, specific requirements for minerals, vitamins, specific fatty acids and amino acids, absence of larval and broodstock diets, and pilot-testing of laboratory-developed grow-out diets.

Guidelines on the use of locally available ingredients for practical diets with adequate protein, fat, carbohydrate and cholesterol levels were suggested. More studies were recommended to ascertain specific nutritional requirements particularly for amino acids, fatty acids, minerals and vitamins.

The paper drew varied reactions. The need for determining economics of feeding in semi-intensive culture systems was stressed in the light of present difficulties in importing raw materials for prawn feeds and spiralling capital and operational costs. It was also felt that most prawn culturists are not ready to adopt the semi-intensive and intensive culture methods; it was suggested that a two-stage culture system be adopted instead: the prawn is grown to 15-20 g in the first stage with only fertilization in large ponds, and then grown to market size in the second stage using smaller ponds with feeding.

It was recommended that intensive studies be conducted by SEAFDEC AQD on feed development both in the laboratory and field, that research results be disseminated as soon as possible, and that promising feeds be tested in the research station before they are field-tested in farmers' ponds. Private sector should play an active role in supporting research on the development of economical feeds, it was stressed.

On feed development, the following workshop recommendations were formulated:

1. Formulation of cost-efficient practical prawn rations using locally available ingredients, with only low-value fish species to be considered for fish meal;
2. Field-testing of promising feed formulas produced in the laboratory to be done at the SEAFDEC Leganes Research Station before their pilot-testing in cooperators ponds;
3. An indication by manufacturers of the guaranteed analysis, ingredients, date of manufacture, inclusive dates for use, and stability rate of feeds;
4. The establishment by SEAFDEC AQD, in cooperation with private or government agencies, of an analytical laboratory to service the needs of fishfarmers for proximate analyses;
5. Assistance by private fishfarmers in the funding of specific research studies on feed development not among the approved studies of AQD for the year;
6. Establishment by SEAFDEC AQD and feed manufacturers of feeding schemes and schedules, giving information on the start of feeding, rates and frequency of feeding for different growth stages.
7. Inclusion of the economic aspects of feeding prawn as part of the information to be gathered.
8. Reduction, if not elimination, of taxes on imported feed ingredients until such time as local ingredients are determined and made available.
9. Considering low-value fish species for fish meal.
10. Closer cooperation between farmers and manufacturers in pond evaluation of commercial feeds.

## POND CULTURE

The paper discussed the extensive and semi-intensive methods of prawn culture. It reviewed the history of pond cultivation of *Penaeus monodon* during the last three decades and the major contributions to its culture, cultivation and production in the Philippines. It also touched on the market demand from Japan which at present is the main importer of Philippine prawns. The major discussion however dealt on the extensive and semi-intensive culture methods, the former being widely practised by prawn farmers and the latter being the most viable and more easily adaptable method for culture in ponds. Although the old practice of direct stocking of fry in grow-out ponds is convenient, it gives unreliable fry survival rates. Thus, the nursery system has been devised to improve fry survival. The different nursery systems were discussed in detail as intermediate holding systems of wild or hatchery-bred fry. The factors that affect prawn production in grow-out ponds were discussed for both extensive and semi-intensive culture methods.

In the workshop session, various constraints in prawn pond culture were emphasized including lack of appropriate knowledge on site suitability, pond design and construction, pond preparation, and pond management. Specifically, the following constraints were considered:

### 1. Site suitability

While there may be a "correct" salinity mix for raising prawns, it was agreed that the lack of freshwater sources is not a constraint. However, optimal yield may not be attained if the proper salinity requirement is not met. It was suggested that the physiological requirement of the animal be considered since an optimum salinity range exists for different aquaculture species. The fishfarmer may be better off economically in culturing different species rather than raising prawns where optimal yields are not produced. Corollary to this, it was suggested that fishfarmers having freshwater ponds should raise *Macrobrachium sp.* instead of *P. monodon*.

Another site suitability factor is accessibility of the ponds to the operator since success in pond operation rests substantially on proper management and close supervision.

### 2. Pond design and construction

Before redesigning ponds for prawn culture, it was suggested that pond owners look at existing designs. Owners should also consider whether to go into extensive, semi-intensive or intensive culture. For extensive culture, existing milkfish ponds may be suitable. For semi-intensive culture, a depth of at least 1 m above the highest tide line is preferred for ease in draining. The use of a pump, 2-gate system, and paddle wheel aerator was also recommended. Most semi-intensive ponds in Taiwan are smaller (less than 1/2 ha) and with concrete dikes. It was noted that one important factor in the success of the operation is close supervision by the owners.

On the reconstruction of leaking dikes, a practical hint offered was to use plastic sheets along the dike. Another was by digging a trench along the leaky area and using the excavated material as reinforcement for the dike. It was suggested that the proper soil type be selected for building dikes. In the long run, concrete dikes may be more economical than earthen dikes. There are two prevailing shapes of semi-intensive ponds used by SMC (square, 50 m 50 m, and rectangular, 1.2 ha in area). Survival rates attained with these shapes were not significantly different.

### 3. Pond preparation

For extensive culture, the traditional scheme of preparing milkfish ponds (drying, plowing, pH test, liming if necessary, application of organic and inorganic fertilizer) was recommended. The preparation of intensive and semi-intensive ponds follow a similar procedure: plowing and complete drying to avoid anaerobic decomposition were emphasized. Non-biodegradable pesticides must be avoided because they leave residues that might be accumulated by the animals. Biodegradable types coming from plant sources (such as rotenone derived from derris roots) are recommended but this natural pesticide is difficult to import. A practical method using ammonium sulfate and lime at a 1:5 ratio was also recommended.

### 4. Feeding management

No feeding is actually required in the extensive method of culture although some fishfarmers occasionally throw chopped unwanted fish species (trash fish) into their ponds. For semi-intensive culture, a scheme based on the average body weight and estimated survival, as practised at the Leganes Station of AQD was presented as follows:

*Average Body Weight (ABW) 0.5-5 g - 10% estimated biomass at 90% survival*

*ABW 5-10 g — 8% estimated biomass at 80% survival*

*ABW 10-15 g — 6% estimated biomass at 70% survival*

*ABW above 15 g — 4% estimated biomass at 60% survival*

*Feeding was done twice a day at equal proportions for the daytime and nighttime rations. At SMC, feeding is administered five times a day. Nighttime (10 p.m.) ration constitutes 30-40% of the daily ration, the early morning (7 a.m.) ration 20-30%, while the late morning, mid-day and late afternoon*



*rations make up the rest. Daily rations were computed starting at 10% of the estimated biomass for the early growing period and gradually reduced to 4% during the first month of culture.*

## **5. Water management**

Water management for the extensive culture method relies mainly on tides. Pumps are a must for semi-intensive and intensive methods where water may have to be changed even at neap tide. The use of bagnets or other means of filtering water was recommended to prevent entry of predators.

Prospective farmers were urged to invest in essential instruments (such as a refractometer) and to teach their caretakers proper water management. At SMC, aeration is used for stocking densities as high or higher than 60,000/ha. A threshold of 4-5 ppm dissolved oxygen is required for growth by most organisms. Dissolved oxygen levels in ponds must not be allowed to dip below 4-5 ppm because below this level food consumption, which affects growth rate, decreases.

## **6. Diseases**

Preliminary results of a study on soft-shelling going on at SEAFDEC AQD were presented. Four factors have been recognized as possible causes of soft-shelling, namely, nutritional, microbial (chitinoplastic bacteria), environmental (e.g. calcium levels, oxygen, salinity), and chemical pesticides as possible inhibitors of chitin synthesis.

A survey of ponds in Iloilo, Capiz and Aklan that have produced some soft-shelled prawns indicated the following general characteristics: low dissolved oxygen (4-6 ppm), high salinity (32-40 ppt), insufficient pond preparation (no liming, no mineral fertilization, use of non-degradable pesticides, and infrequent water exchange at 1/2 to 1 1/2 month intervals), insufficient natural food, the use of pesticides in adjacent agricultural areas, and low organic matter (less than 7% ) and total nitrogen (less than 1% ) content of pond soil. In SMC, well-managed intensive systems yield less than 3% soft-shelled prawns at harvest.

## **7. Manpower**

The SEAFDEC AQD training program on pond management for caretakers was highly recommended to pond owners for their pond aides. SMC estimates indicate that for every 5 ha of intensive culture pond, two technicians (one for water management, one for feeding) and three labor aides are sufficient.

In the ensuing discussion the characteristic of a suitable site was assessed. Appropriate pond design was discussed. For the other areas in pond management, it was claimed that the information are already available to fishfarmers.

Specifically, the following recommendations were made:

## 1. Characteristics of a suitable site

- a. For extensive culture, a source of brackish water is necessary.
- b. For semi-intensive culture system, a controlled environment is desirable. The use of pump and properly engineered systems are recommended.
- c. The intensive culture system requires a large capital. Like the semi-intensive system, a controlled environment is needed.

## 2. Proper pond design

For extensive culture, existing milkfish ponds are sufficient. For semi-intensive culture, 2-gate and 2-canal systems are recommended in order to accelerate water change.

## 3. Feeding

For extensive culture, the fishfarmers receive inconsistent information on what natural food is best for prawn. Some claim *lablab*, some *lumot*, and still others claim *kusay-kusay (Rupia sp.)*, an aquatic grass, as the best natural food. Researchers were urged to provide consistent information to the farmers.

The history of the prawn industry in Taiwan and Japan can provide practical hints for the development of the local industry. Taiwan started with the extensive method in basically the same manner as the Philippines but has gradually shifted to the semi-intensive method with the use of formulated feeds. Government support for the prawn industry in Taiwan has contributed significantly to the now advanced Taiwanese technology.

The final discussion focused on an ongoing physiological study at the SEAF-DEC AQD. The composition of the hemolymph of prawn is being studied as the animals are placed at different salinities. There are indications that the prawn possesses regulatory mechanisms which compensate for gradual changes in environmental salinity, although not as efficient as those of milkfish. Large and sudden alterations in salinity can change the character of the hemolymph and threaten the life of the prawn. The best salinity is between 16 to 24 ppt. At this salinity range, the prawn need not spend a lot of energy regulating the inorganic ion content of its blood because it is similar to that of its environment. However, it was noted that changing the salinity under laboratory conditions is different from a change in salinity in ponds. In ponds, a change in salinity may also bring about a change in the population organisms in the pond, thereby affecting the nutrition of the animal.

## PROCESSING/MARKETING

The paper presented a comprehensive coverage of the processing and marketing of prawns for export as practised by AA Eximco, a firm based in Roxas City.

Philippine export of *Penaeus monodon* in 1983 was estimated at 4,450 MT of which 2,000 MT was caught in the fishing waters and about 2,450 MT produced from aquaculture. These are mostly exported to Japan and the United States in processed and quick-frozen form.

### 1. *Post-harvest handling*

Processing begins with proper handling after catch or harvest. Freshly caught prawns are packed with crushed ice in insulated containers. In the processing plant, the prawns go through nine processing steps: washing in clean cold water; classifying according to buyer's specifications; sizing according to internationally accepted sizes; weighing according to buyer's requirements; rinsing again with clean cold water before positioning the sized prawns in tin containers; filling up the tin containers with clean fresh water; quick-freezing the processed prawns in the water-filled containers; removing the frozen blocks from the containers and wrapping the blocks successively in plastic bags, consumer packs and bulk packs; and, finally, cold storing the fully wrapped prawns ready for export.

Processing is labor-intensive. About 30 people are required to process one metric ton per day. All the steps can be mechanized using custom-built machines but this is not practicable in the Philippines. Use of high-standard quick-freezing equipment for shorter freezing time is necessary.

Mechanization of the quick-freezing process but manually performing the other processes, all under very sanitary conditions, is advisable. The faster the prawns are quick-frozen, the better their quality.

Observance of hygienic practices all throughout the operations particularly in manual processing was stressed. Negligence and poor sanitary conditions often leads to rejected products due to unacceptable bacterial loads. These rejections in the export market cause financial damage and tarnish the reputation of the Philippines as a source of prawn and fish products.

Marketing is another important aspect in the exportation of prawns. Marketing involves not only quality but also pricing, delivery, promoting and competing. Pricing of prawns depends on many factors such as supply

and demand, foreign exchange rates, labor and packaging cost, freight, taxes, and government policies and incentives.

The delivery of exported prawns has to be consistent and reliable. Continuous supply should be assured. To establish a brand name and increase saleability, an extensive promotional campaign is essential. The Philippines ranked among the top ten in 1982 in total exports of prawns to Japan, with a total volume of 3,694 MT (valued at US \$37,521,000). Competition is keen among countries of the Asia-Pacific Region and some countries in South America. Therefore, in order not to be outdone, we have to keep abreast of the latest technology not only to increase production but to improve quality of taste as well. Philippine exporters should likewise intensify their efforts at expanding the United States market and penetrating the Middle East and European markets which so far remain untapped by local exporters.

The Philippines has a tremendous export potential and a vast national capacity for production. The export industry is still in its infancy stage and needs a strong government support to be more price competitive in the world market; one incentive from the government would be the relaxation of the 6% export tax. To realize the potential, government and the private sector should actively engage in research and development for aquaculture.

The Philippines is not the only country exporting prawns to Japan. It must be able to compete favorably with other countries like Indonesia, Taiwan, India, China, Pakistan and Bangladesh. Only two exporting firms have penetrated the U.S. market.

Prospects for increased exports are bright but it is the role of the industry and the government to convert this great potential into increased production. The present 6% export tax is seen as a hindrance to industry growth. The Philippines is the only country that imposes tax on export of prawns.

Processing problems include: (a) high initial loadings of bacteria in processed prawns, (b) high ambient temperature in processing and transport, (c) manual peeling of prawns which accelerate bacterial contamination, (d) poor facilities, and (e) low acceptance of processed Philippine prawns in other countries.

While *P. monodon* is expected to remain as a major penaeid species for export, there is now a need to diversify into other penaeid species. In pond areas not suited for sugpo culture, other species may be cultured. Sugpo comprises some 10-15% of the total prawn in the market even as other markets like the U.S. prefer smaller species so that *P. indicus* might be a better candidate. SEAFDEC AQD has ongoing research studies on *P. indicus* culture.

Since quality is an important aspect of processing, there is need to define what the processors-exporters mean by good quality. After the visual criteria like color (true color and absence of black spots), texture (glossy appearance, hard shell, etc.), completeness of body parts, and odor are satisfied, microbiological tests are done to ensure compliance with export quality standards.

The product must reach the processing plant as quickly as possible. However, in areas which are not served by airplanes, the need to observe proper packing pro-

cedures in order to preserve the coldness of the product is more important. In all cases, proper icing at a 1:1 ratio as a rule of thumb should be observed. The shrimp should be chilled only, not frozen, during transport to the processing plant. If they are frozen hard, they will have to be thawed during processing and this will mean further reduction in quality.

The potential exists for marketing our prawn in forms other than frozen, i.e. "convenience food." However, there is a need to establish a good reputation in exporting frozen prawns.

Recommendations were presented for the elimination of bacterial load in prawns. As practiced by the Food Terminal Inc, prawns are frozen using individual quick-freezing, or freezing in blocks which have proved to be effective.

## **2. Marketing**

Obviously, sugpo is presently produced for the export market because even at current production levels, the domestic market cannot absorb the volume. Besides, very few local consumers can afford to pay the price which the prawns fetch in the export market.

One of the major problems facing producers is under-utilization of plant capacity. Processing plants can still absorb all the domestic produce even if the quantity doubles from current levels.

It is essential for us to maintain a competitive edge over other countries possibly by lowering production costs. Other markets need to be explored and one of the most lucrative outlets is the US. Taiwan has already entered the US market and the Philippines has some exposure through the Ayala Corp. and Sugeco. The European market is not very attractive at the moment because of high cost of transport over such a distance and unrealistically high quality standards.

At present the best the farmers could do is observe proper icing of the product.

The export marketing of prawns was discussed, the details of which are contained in the "Primer on the Simplified Export Procedures and Documentation" published by the Bureau of Foreign Trade of the Ministry of Trade and Industry which was also made available to the participants.

Finally, it was recommended that a solid reputation be established for exported Philippine frozen prawns through proper handling from pond to processing plant.

## **POLICIES/FINANCING**

The paper discussed briefly Philippine Government policies on aquaculture. It emphasized the value of conservation to promote ecological stability of our natural resources. Mentioned were the steps the government has done to conserve local stock of prawn spawners, particularly the issuance and implementation of Fishery Administrative Order 143 which provides for the total ban on the export of all live stages of the tiger prawn.

Existing policies on aquaculture do not need much change in the immediate future. National policies are translated into specific laws which are transformed by the Ministry of Natural Resources into rules and regulations, and further translated into operating procedures by the Bureau of Fisheries and Aquatic Resources, the Fishery Industry Development Council, and the Philippine Fishery Development Authority. In order to fulfill policy goals, an evaluation of the institution and people involved in carrying out a policy should be made. Thus, it is a must to assess an institution's capability in policy study, formulation and implementation to understand why policies succeed or fail.

The Ministry of Natural Resources (MNR) uses the ecosystem management approach which seeks a balance between immediate gains and long-range benefits in the exploitation of the country's natural resources. A key MNR policy is the promotion of ecological stability through conservation. The approach equates the soundness and viability of a technology with its effectiveness in satisfying needs. This has been operative in the program thrusts of the Ministry. These thrusts subscribe to the following considerations: (1) that deliberate care should accompany the imposition of human techniques in natural systems; and (2) that human intervention in nature's processes cannot be avoided, but the risks from such intervention can be minimized.

A case in point is the mangrove dilemma. A policy allowed the conversion of mangrove swamps, the most productive branch of the marine ecosystem, into commercial fishponds to accelerate food production through aquaculture. Although its immediate effect is increased fish production, this conversion has drastically reduced the total area of mangrove swamps which may eventually lead to the collapse of nearshore fisheries and the decline of total fish harvest. Recognizing this problem, the Ministry, through P.D. 950, required every fishpond lessee to replant or reforest at least a 20-m strip from the riverbank.

Several presidential directives have pushed for the acceleration of aquacul-

ture development. Through the MNR, the Aquaculture Industry Development Program was formulated to chart the general policy directions, targets and strategies for the industry. Legislations were passed to ban export of all live stages of tiger prawn, reduce tariff duty on imported prawn feeds and aquaculture equipment, authorize additional incentives for agricultural and fisheries activities through the Agricultural Investments Incentives Act (PD 1159), and improve the country's foreign exchange position through export expansion of processed fish and fishery/aquatic products.

The area on credit and financing was also discussed, including loan exposure and incentives and subsidies for the prawn industry from the government.

The Development Bank of the Philippines (DBP), the Central Bank (CB) and the Philippine National Bank (PNB) are some of the major credit institutions with regular lending programs for aquaculture projects aside from being involved in the Biyayang Dagat Supervised Credit Program. Foreign funding institutions like the Asian Development Bank (ADB) and the International Finance Corporation (IFC) have also provided credit programs for various aquaculture projects.

The DBP, under its regular program and the DBP-IBRD Credit Lines, has so far released P413.4 million, the Central Bank P242 million, and the PNB P92 million. Fishpond construction and development have received the highest share of financing in terms of loan exposures by type of aquaculture project while there are no long-term lending programs specific to prawn farming.

Among the minor credit institutions or programs are the Land Bank, the Agricultural Credit Administration (ACA), the Biyayang Dagat and the Kilusang Kabuhayan at Kaunlaran (National Livelihood Program). The last two have lending schemes that aim to upgrade the economic status of small fishermen and fish-farmers.

In the workshop session, it was suggested that all existing policies be thoroughly reviewed to determine if there is need for additional policies. The workshop affirmed the fact that at, present, policies are more regulatory than developmental to the prawn industry

Various policy issues were recommended, including the total ban on the exportation of all five stages of the genus *Penaeus*, feed development for other penaeids, reduction of the tariff duties for the importation of rotenone as well as the use of locally available substitutes for this material.

On financing and incentives for the prawn industry, the workshop asked the government bodies to coordinate with the private sector and banking representatives in formulating a packaged financial scheme which will involve the following vital components of the industry: (a) production, (2) processing, (3) marketing, (4) manpower development, and (5) support for research.

It was recommended that the government develop a package of short-term loans for the prawn industry which is similar to the existing crop loans in agriculture.





# **PARTICIPANTS, OBSERVERS, GUESTS**



## PARTICIPANTS

1. Abdulgafor N. Abdua  
BFAR Region XII  
PC Hill, Cotabato City
2. Jose Abello  
Bacolod City
3. Saturnino A. Abesamis  
127 Connecticut, Greenhills  
Metro Manila
4. Victor B. Advincula  
San Jose, Sipalay  
Negros Occ.
5. Bordia C. Alamara  
Davao del Sur School of  
Fisheries, Malalag  
Davao del Sur
6. Marissa D. Albaladejo  
BFAR, 860 Arcadia Bldg.  
Quezon Ave., Quezon City
7. Sulpicio A. Alojipan  
Tagum, Davao
8. Rodolfo Z. Alvarez  
63 Alunan Ave.  
Bacolod City
9. Leonito Anasarias  
FFFC, Talisay, Cebu
10. Romeo C. Apostol  
San Sebastian, Hagonoy  
Bulacan
11. Simeon M. Arce  
Village Marketing  
Kalibo, Aklan
12. Damaso Arches  
Baybay, Roxas City
13. Socorro M. Arconado  
Ministry of Natural Resources  
Visayas Ave., Diliman, Q.C.
14. Ray Q. Atienza  
Magsaysay St., Ciu  
Zamboanga del Sur
15. Lorenzo Aurelio  
54 Lizares Ave.,  
Bacolod City
16. Miriam C. Balgos  
Philippine Council for  
Agriculture and Resources  
Research and Development  
Los Banos, Laguna

- Los Banos, Laguna
17. O.Q. Ballesteros  
Planters Products Inc. (PPI)  
Legaspi Village, Makati
  18. Tranquilino Benigno  
Davao Regional Institute of  
Fisheries Technology  
Panabo, Davao
  19. Ma. Paz Emilia B. Bihis  
Philab Industries, Inc.  
1097 Pasong Tamo St.  
Makati
  20. Victorio A. Borja  
ASD, Development Bank of the  
Philippines  
Buendia Ave., Makati
  21. Ramon Buenaflor  
Development Bank of the Philippines  
Iloilo Branch, Iloilo City
  22. Oscar M. Buenvenida  
Vitarich Corporation  
Sarmiento Bldg., Pasong Tamo Ext.  
Makati
  23. Edron C. Bullo  
BFAR Region VI, Molo  
Iloilo City
  24. Amelita N. Canton  
Laguna Lake Cooperative Dev.  
Program (LLCDP)  
Farm Systems Development  
Corporation (FSDC)  
Pasig
  25. Gilberto Castro
  26. Jose Manalo E. Catalan  
Panay State Polytechnic College  
Pontevedra, Capiz
  27. Cesar A. Cantor  
BFAR, Roxas City
  28. Warmelo Ching  
Vitarich Corporation  
Marilao, Bulacan
  29. Lilia S. Cordero  
Balasan, Iloilo
  30. Teodoro C. Cruz  
Agriculturists Association  
440 Magsaysay Ave., Davao City
  31. Federico M. Delina, Jr.  
Baliangao School of Fisheries  
Baliangao, Misamis Occ.
  32. Juliet B. Demo-os  
BFAR, Molo  
Iloilo City
  33. Gregorio Dichupa  
Difran Dev Corp.  
(Terra-Mar Farms), Bulacan
  34. Helen A. Diocera  
Iloilo City

35. George B. Ditching  
Philippine Refining Co.  
Manila
36. Francisco V. Domingo, Jr.  
54 Lizares Ave.  
Bacolod City
37. Rita P. Donato  
MNR, Quezon City
38. Rafael Falmiano Dorado  
Panay State Polytechnic College  
Pontevedra, Capiz
39. Ramon Doromal, Jr.  
120 Timawa St.  
Molo, Iloilo City
40. Ramon Doromal, III  
120 Timawa St.  
Molo Iloilo City
41. Pablito T. Encabo  
Baliangao School of Fisheries  
Baliangao, Misamis Occ.
42. Joan Aura Enciso  
Universal Robina Corp.  
CFC Bldg., Pasig  
Metro Manila
43. Antonio C. Espelera  
Fortuna Subdivision  
Silay City
44. Joselito R Espinosa  
ATG Corp. 504 P. del Rosario Ext.  
Cebu City
45. Ma. Asuncion Evangelista  
MNR, Visayas Ave.  
Diliman, Quezon City
46. Jose E. Ezpeleta, Jr.  
Maguaga, Pantukan  
Davao del Norte
47. Antonio B. Ferrolino  
Victorias Milling Co., Inc.  
Negros Occidental
48. Agripina N. Fernandez  
FIDC 6th Floor  
Phil. Heart Center for Asia  
East Ave., Diliman Q.C.
49. Jonathan Floro  
Davao Regional Institute of  
Fisheries Technology  
Panabo, Davao
50. Joselito C. Fojas  
MNR, Quezon City
51. Jose S. Garrido, Jr.  
BFAR, Tacloban City
52. Wilfredo M. Gonzaga  
Sagay, Negros Occidental
53. Francis Griño  
Villalobos St., Jaro  
Iloilo City
54. Rex J. Gulanes  
Bluecrest Aquafarms Inc.  
46 D.B. Ledesma, Jaro  
Iloilo City

55. Rex J. Gulanes Molo, Iloilo City
56. Adelina S. Hassan Davao del Sur School of Fisheries  
Malalag, Davao del Sur
57. Tilan A. Hassan Davao del Sur School of Fisheries  
Malalag, Davao del Sur
58. Ricardo G. Hechanova 317 San Agustin St.  
Iloilo City
59. Jose A. Hernandez Roxas City  
Capiz
60. Franco J. Hollero 46 D.B. Ledesma St.  
Jaro, Iloilo City
61. Alfredo O. Isidro Development Bank of the Philippines  
Buendia Ave., Makati, MM
62. Benjamin Jalandoni Bacolod City
64. Ernesto Jamandre Butuan City
65. Nelson Jamandre Tigbauan, Iloilo
66. Oscar J. Japitana 46 D.B. Ledesma St.  
Jaro, Iloilo City
67. Mario Jugador Aquafarm, P.O. Box 18  
Cagayan de Oro City
68. Mariano Laburada One Source Scientific Inc.  
880 Rizal Ave., Sta., Cruz  
Manila
69. Marlon Lamera HJR Fishing Ind.  
Banilad, Cebu City
70. Oliverio G. Laperal 781 J.P. Rizal Ave.  
Makati, Metro Manila
71. Ismael S. Lapus Orani, Bataan
72. Teofilo D. Lasao Rm. 309, Manila Bank Bldg.  
Ayala Ave., Makati, Metro Manila
73. Cyd H. Latuño NRDC, MNR Bldg.  
Visayas Ave., Q.C.
74. Ismael Lazaro Nocomin 11th Floor, Vernida IV Bldg.  
Alfaro St., Salcedo Village, Makati
75. Julieta A. Legados Quirino Regional Institute of  
Fisheries Technology  
Carmen, Cebu
76. Jesusa A. Legaspi BFAR. 860 Arcadia Bldg.  
Quezon Ave., Q.C.

- |     |                      |  |
|-----|----------------------|--|
| 77. | Edgardo Lizares      | Lizares Ave., P.O. Box 129<br>Bacolod City   |
| 78. | Francisco V. Lizares | Bago City  |
| 79. | Ricardo Lizares      | Bago City  |
| 80. | Roberto T. Lorenzo   | Dinagat School of Fisheries  |
| 81. | Rosita S. Macariola  | 243 J. Teodoro St., 8th Ave.<br>Caloocan City  |
| 82. | Susan Macariola      | 243 J. Teodora St., 8th Ave.<br>Caloocan City  |
| 83. | Ruperto C. Magno     | 67 P. Tuazon, Cubao Q.C.   |
| 84. | Romulo Noel L. Manga | 1st. St., Guadalupe Village<br>Lananag, Davao City                                       |
| 85. | Benita D. Marcial    | Fishery Industry Dev. Council<br>(FIDO, 6th Floor, PHCA Bldg.<br>East Ave., Diliman Q.C. |
| 86. | Lucio B. Martin      | Tanghal Fishpond Pollac<br>Parang, Maguindanao   |
| 87. | Gesar C. Matulac     | BFAR Region VI<br>Iloilo City  |
| 88. | Thelma P. Mayuga     | New Washington, Capiz  |
| 89. | Leonardo Medina      | 207 - A Lati St.<br>Omboy Abucay, Bataan 1906  |
| 90. | Edwin Tan Mercado    | 8 Albany St., Greenhills<br>San Juan   |
| 91. | Narciso de la Merced | Delta Motor Sales Corporation<br>Ortigas Avenue cor. EDSA<br>Mandaluyong                 |
| 92. | Raul C. Miliaria     | Agro-Industrial Foundation<br>College of the Philippines<br>Davao City                   |
| 93. | Tomas F. Molina      | SGV & Co., 105 de la Rosa Street<br>Legaspi Village, Makati                              |
| 94. | Alfredo Montelibano  | Planters Products Building<br>Legaspi Village, Makati                                    |
| 95. | Arcadio Monzon       | Kalinisan, Naujan<br>Mindoro, Oriental   |
| 96. | C.R. Monzon          | MNR, Quezon City   |
| 97. | Wilfredo C. Ngo      | Orient Parts and Hardware<br>Lupon, Davao Oriental                                       |

98. Tadahide Noro  
Apolinario R. Apacible  
School of Fisheries, Nasugbu  
Batangas
99. Lorenzo S. Onrubia  
Bagong-Ilog, Pasig
100. Margarita Ortigas  
WDSScott - Agriventures  
Management, 13th Floor  
Strata 100 Building Emerald Avenue  
Ortigas Commercial Complex  
Pasig
101. Bernabe C. Paller  
Universal Robina Corporation  
Bagong Ilog, Pasig
102. Regalado Q. de Pano  
Orani Rural Bank, Inc.  
Orani, Bataan
103. Lutgarda L. Penolio  
860 Arcadia Building, Quezon Avenue  
Quezon City
104. Nilda O. Pegarro  
Dinagat School of Fisheries  
Surigao del Norte
105. Jaime Pineda  
SGV Building, de la Rosa Street  
Makati
106. Jesus Poblete  
3C 4th Avenue, Quezon City
107. Ihra O. Potestas  
46 D.B. Ledesma Street  
Jaro, Iloilo City
108. Namnama Amanda Prado  
BFAR, 860 Arcadia Building  
Quezon Avenue, Quezon City
109. Luciano Puyod III  
Davao City
110. Marciano D. Quimsing  
371 Rizal Street, Iloilo City
111. Ruben T. Rabe  
BFAR Roxas City
112. Dominador V. Racho  
BFAR, Tuguegarao, Cagayan
113. Divina Santiago Reyes  
Food Terminal Inc., Taguig
114. Alicia L. Robelo  
District Fishery Office  
Kalibo, Aklan
115. Manuel Rodriguez  
12th Street, Capitol Subd.  
Bacolod City
116. Capistrano Roflo  
Lupon, Davao Oriental
117. Raul Roldan  
FIDC, 6th Floor, PHCA Bldg.  
East Avenue, Diliman, Q.C.
118. Manuel del Rosario  
271 Luna St., Lapaz, Iloilo City
119. Arch. Quin A. Sajorda  
38 Bahi, Albuquerque, Bohol
120. Pedro S. Santos  
San Jose, Hagonoy, Bulacan



121. Enone V. Saracho Don Mariano Marcos Memorial State  
University College of Fisheries  
Balaoan, La Union
122. Angelito Sarmiento Vitarich Corporation  
Sarmiento Bldg., Pasong Tamo Ext.  
Makati
123. Antonio U. Serrano Robina Farms Fertilizer Division  
Gov. E. Rodriguez Ave.  
Bo. Ugong, Pasig
124. Jose D. Seville, Jr. Hipona, Pontevedra, Capiz
125. Diana C. Shepherd IDRC-ICLARM Project  
CAS-UPV, Iloilo City
126. Eric Brett Shorthouse G.P.O. Box 241, Townsville  
Queensland, Australia 4810
127. Eric M. Sims Philippine Fisheries Development  
Authority, 11th Floor  
PPSTA Bldg. III, Banaue St., QC.
128. Jesusa S. Sioco BFAR, Kalibo, Aklan
129. Eufemia Sionosa First Farmers Food Corporation  
Talisay, Negros Occ.
130. Eduardo Sison Vitarich Corporation  
Makati
131. Amideus Tan San Jose Village  
Tiza, Roxas City
132. Eusebio C. Tanghal Cotabato City
133. Rodolfo Torreda Planters Products Bldg.  
Legaspi Village, Makati
134. James L. Torres UP in the Visayas, Iloilo City
135. Luis Miguel Treboal A. Montelibano Hijos, Inc.  
Bacolod City
136. Nida Ty UP in the Visayas, Iloilo City
137. Editha M. Valerio Unisan, Quezon
138. Jojo Valerio 15-B Cabegar, Project 4, QC
139. Teddy Valerio 15-B Cabegar, Project 4, QC
140. Ernesto Velasco 105 Aguirre St., Legaspi Village  
Makati
141. Enrique V. Villaluna Balayong St., Bacolod City
142. Glenn M. Villano GMV Industrial Sales and Services  
MacArthur Hi-way, Matina, Davao City

- |      |                       |  |
|------|-----------------------|--|
| 143. | Rene Villarica        | Room 204, Philamlife Bldg.<br>Jones Ave., Cebu City  |
| 144. | Felix D. Villarreiz   | 679 Aurora Quezon St., Davao City  |
| 145. | Juanito T. Villegas   | Laguna Lake Cooperative Development<br>Program, Farm Systems Dev. Corp.<br>17 Shaw Blvd., Pasig, |
| 146. | Vicente F. Viray, Jr. | Apolinario R. Apacible School of<br>Fisheries, Nasugbu, Batangas                                 |
| 147. | Alfonso Zayco, Jr.    | A.M. Jijas, Bacolod City   |
| 148. | Isidro P. Zayco       | Sampaguita St., Capitalville<br>Bacolod City   |

### **Invited Panelists and Resource Speakers**

- |     |                     |   |
|-----|---------------------|---|
| 1.  | Ruperto Angudong    | Bacolod City  |
| 2.  | Antonio Dator       | Philippine International Center<br>Tordesillas St., Salcedo Village<br>Makati.                              |
| 3.  | Araceli Dolendo     | Food Terminal Inc., Taguig  |
| 4.  | Fructuso Escudero   | Southern Philippines Development<br>Authority, Zamboanga City   |
| 5.  | Rafael Guerrero III | Technology Resource Center<br>Buendia Ave., Makati.   |
| 6.  | Ricaredo Gulanes    | 46 D.B. Ledesma St., Jaro, Iloilo City  |
| 7.  | Concepcion Lua      | Sugeco, Cebu City   |
| 8.  | Victor Mancebo      | San Miguel Corp., 6766 Ayala Ave..<br>Makati.   |
| 9.  | Mario Songco        | Development Bank of the Philippines<br>Buendia Ave., Makati   |
| 10. | Rene Obregon        | Masaganang Sakahan Inc.<br>Integrated Livestock Crop.<br>Estate Project<br>Carugay, Magsaysay, Mindoro Occ. |
| 11. | Florian Orejana     | UP College of Fisheries, QC   |
| 12. | Antonio Ortiz       | Zamora St., Roxas City  |
| 13. | Mayor Serafin Roman | Orani, Bataan   |
| 14. | Romeo de Sagun      | BFAR, Arcadia Bldg., 860 Quezon Ave.<br>Quezon City   |
| 15. | George Tan          | 100 H.Lopez St., Manila   |

- |     |                        |                                    |
|-----|------------------------|------------------------------------|
| 16. | Marcelino Tumanda, Jr. | MSU-IFRD, Naawan, Misamis Oriental |
| 17. | Bartolome Quintana     | Central Bank of the Philippines    |

### **SEAFDEC AQUACULTURE DEPARTMENT PARTICIPANTS**

1. Thia-Eng Chua
2. Ronaldo Ferraris
3. Rufino S. Ignacio
4. Alejandro V. Lim, Jr.
5. Jose A. Llobrera
6. Romeo C. Mesa
7. Rolando R. Platon
8. Alfredo C. Santiago, Jr.
9. Hermenegildo S. Sitoy
10. Yasuhiko Taki
11. Pastor L. Torres, Jr.
12. Angelito T. Vizcarra
13. Adam L. Young

### **Panelists, Speakers, Chairmen and Rapporteurs from SEAFDEC**

- |                             |                          |
|-----------------------------|--------------------------|
| 1. Jose Agbayani, Jr.       | 6. Danilo Israel         |
| 2. Florentino Apud          | 7. Felicitas P. Pascual  |
| 3. Ma. Cecilia L. Baticados | 8. Jurgenne H. Primavera |
| 4. Relicardo Coloso         | 9. Arthur L. Sanchez     |
| 5. Emmanuel Cruz            | 10. Antonio Villaluz     |

### **Discussants**

- |                           |                         |
|---------------------------|-------------------------|
| 1. Renato Agbayani        | 15. Alcestis Llobrera   |
| 2. Veronica Alava         | 16. Romeo Mesa          |
| 3. Florentino Apud        | 17. Oseni Millamena     |
| 4. Eva Aujero             | 18. Dioscoro de la Pena |
| 5. Lita V. Benitez        | 19. Gilda Lio-Po        |
| 6. Ruby Bombeo            | 20. Beato Pudadera, Jr. |
| 7. Mae Catacutan          | 21. Emilia Quinitio     |
| 8. Kaylin Corre           | 22. Noel Solis          |
| 9. Roselyn Duremdez       | 23. Fernando Sunaz      |
| 10. Fe Dolores Estepa     | 24. Nilda Tabbu         |
| 11. Nilo Franco           | 25. Leonardo Tiro, Jr.  |
| 12. Rogelio Gacutan       | 26. Isidra Tuburan      |
| 13. Piniy Kungvankij      | 27. Angelito Vizcarra   |
| 14. Alejandro V. Lim, Jr. | 28. Yoshibumi Yashiro   |

## Observers

1. Jesus Manalo Almendras
2. Jocelyn Antiporda
3. Amy Arisola
4. Dan Baliao
5. Myrna Bautista
6. Rito Bombeo
7. Robmar Buensoceso
8. Jose Canto, Jr.
9. William Chan
10. Corazon Duenas
11. Lolito Dullin
12. Emilio Gapit, Jr.
13. Edgardo Gargantiel
14. Dante Gerochi
15. Diana Gonzales
16. Danilo Javellana
17. Einstein Lavina
18. Suzette Licop
19. Clarissa Marte
20. Jonathan Nacario
21. Rolando Ortega
22. Eduardo Rodriguez
23. Ruby Salde
24. Romulo Samson
25. Hilario Saracho
26. Zenaida Suayan
27. Josefa Tan
28. Rosita Tenedero
29. Lillian Tiro
30. Cesar Villegas
31. Jessie Banno
32. Milagros dela Pena
33. Pedro Gutierrez

## Guests

1. Kazutsuga Hirayama
2. Salvador Pamplona
3. John Sumner
4. Renu Yashiro

# **REVIEW PAPERS**



# SEED PRODUCTION AND THE PRAWN INDUSTRY IN THE PHILIPPINES

J.H. Primavera  
Researcher  
SEAFDEC Aquaculture Department

## INTRODUCTION

In any aquaculture system, the major components are seed and feed. The same is true for *Penaeus monodon* known locally as sugpo, lukon, pansat or by its trade/export name "black tiger." (The present discussion will refer to *P. monodon* unless otherwise specified). This paper is an attempt to give a state-of-the art of prawn hatchery technology and wild fry collection in the country, focus on technical and non-technical problems, and offer solutions and policy recommendations.

First, a brief review of the natural and production cycles of sugpo. The life cycle of sugpo starts with the spawning of the gravid female in offshore waters with an average of 500,000 eggs/spawning (Fig. 1). They hatch after 12-15 hours into the first larval stage or nauplii, it takes another 10-12 days for them to pass through two more stages -- protozoa and mysis. Only a small fraction of the larvae survive predators and the vagaries of nature to metamorphose into the postlarval stage.

The young postlarvae or fry move shorewards and start appearing in coastal waters on the 14th day of their postlarval life (PL<sub>14</sub>). They continue migration towards the estuarine areas such as mangroves which serve as their nurseries or feeding grounds, growing to larger juveniles, postjuveniles and subadults.<sup>1</sup>

First mating of subadults occurs at 4-5 months of age in the inshore areas (Motoh 1981). However, it is only during or after migration back to the offshore areas that full maturation of the ovaries and first spawning take place at around 10 months to complete the natural cycle. The bottom-dwelling *P. monodon* remain in the ocean up to a ripe age reaching sizes of 500 grams or more unless they die earlier of disease or predation.

The larval rearing phase which starts from spawning of the ripe females to production of the young postlarvae is the basic concern of the hatchery (Fig. 1b). However, the young postlarvae (PL<sub>5</sub> to PL<sub>10</sub>) harvested from the hatchery tank are fragile and need to go through a nursery phase, whether in tanks or earthen ponds. After 1-2 months in the nursery, the so-called juveniles (PL<sub>35</sub> to PL<sub>60</sub>) measuring the width of a matchstick are hardly enough to be stocked in extensive or semi-extensive grow-out ponds. Younger PL<sub>15</sub> to PL<sub>20</sub> may be stocked in intensive ponds. After 3-6 months, the prawns are harvested at marketable sizes of 30-80 grams.

<sup>1</sup>The policy of increasing production from already existing fishponds rather than opening new mangrove areas has helped preserve natural population of crustaceans and finfish by protecting their nurseries.

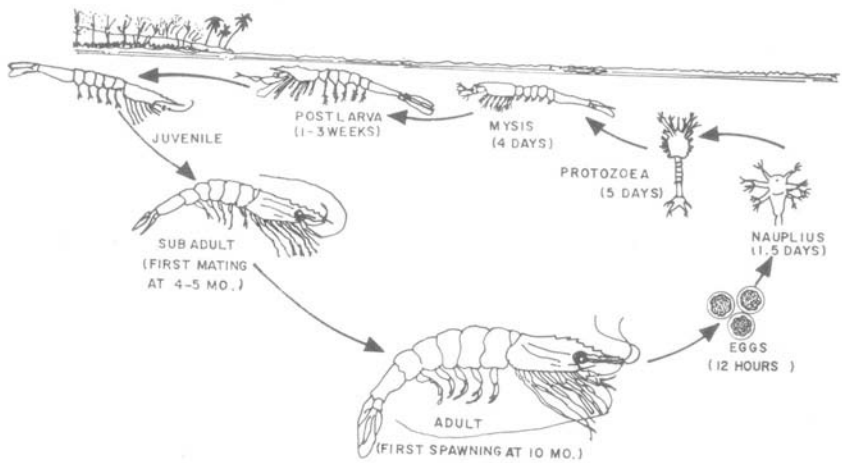

**A. LIFE CYCLE OF SUGPO**

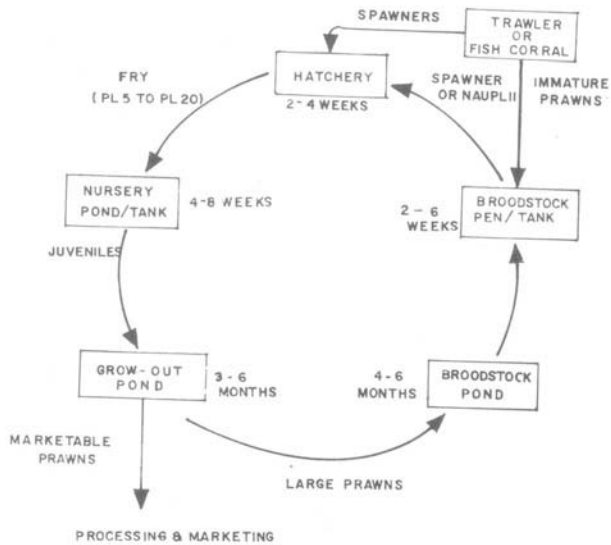

**B. PRODUCTION CYCLE OF SUGPO**

**Fig. 1. Parallels in the (A) life cycle and (B) production cycle of sugpo *Penaeus monodon*.**



In addition to the larval rearing and nursery phases, a hatchery may also go backwards and incorporate a broodstock as an alternative to wild spawners. Maturation and subsequent spawning of the female closes the cycle in captivity.

### WILD FRY

Prawn culture in the Philippine has evolved from the harvest of sugpo and other prawns as by-products of milkfish ponds from wild fry that enter with tidal flushing to the intentional stocking, first of wild-caught fry and later of hatchery-reared fry (Fig. 2).

	SOURCE OF FRY	SPAWNERS	
First Stage	Wild fry	-	Accidental entry with tide
Second Stage	Wild fry from coastal gatherers	-	Intentional stocking in pond
Third Stage	Hatchery fry	Wild spawners (MSU-IFRD, 1970)	Stocked in pond
Fourth Stage	Hatchery fry	Captive/ablated spawners from broodstock (SEAFDEC AQD, 1976)	Stocked in pond

**Fig. 2. Evolution of fry supply in pond culture of prawn.**

Wild fry are caught by different collecting gears according to habitat: fry lures made of grass and twigs for mangrove areas, filter net and fry raft (saplad) for fry migrating in rivers, and filter net (tangab), fry seine (sagyap or sayod) and scissors net (sakag) for shorewaters (Motoh 1981).

Compared to other penaeid species, sugpo fry are not so abundant in our coastal and estuarine waters. In a two-year survey, sugpo constituted only 5.5% of all penaeid fry compared to 85% for putian (Motoh, 1981). With milkfish, on the other hand, it can be assumed that some 900 million fry stocked in ponds from a yearly catch of 1.15 billion given 78.4% survival before stocking in ponds (Villaluz et al 1982). If best industry estimates show 15 million prawn fry stocked in ponds in 1982 (Primavera 1983b), this means a ratio of 60 milkfish to every prawn fry stocked in ponds.

Even with such low population, wild fry still constitute a significant seed source in areas of abundance and in places where prawn farming is new and at the extensive, low-stocking level.

## PHILIPPINE HATCHERIES

### a. History

A 1969 ecological survey by the Mindanao State University Institute of Fisheries Research and Development (MSU-IFRD) (Villaluz et al 1972) marked the first scientific study of *P. monodon* in the country. This was followed by the first experimental hatchery established by MSU-IFRD in 1973. After two years, the SEAFDEC Aquaculture Department started large-tank hatchery operations in Tigbauan, Iloilo followed by the small-scale hatchery in 1977.

On the industry side, the first two commercial hatcheries were established in the late 1960 followed by a third one established in Lanao del Norte by the Panguil Bay Fishpond Owners Association in 1972. These early hatcheries eventually closed largely due to the immature state of hatchery technology at the time. Most of our private hatcheries were built after 1975.

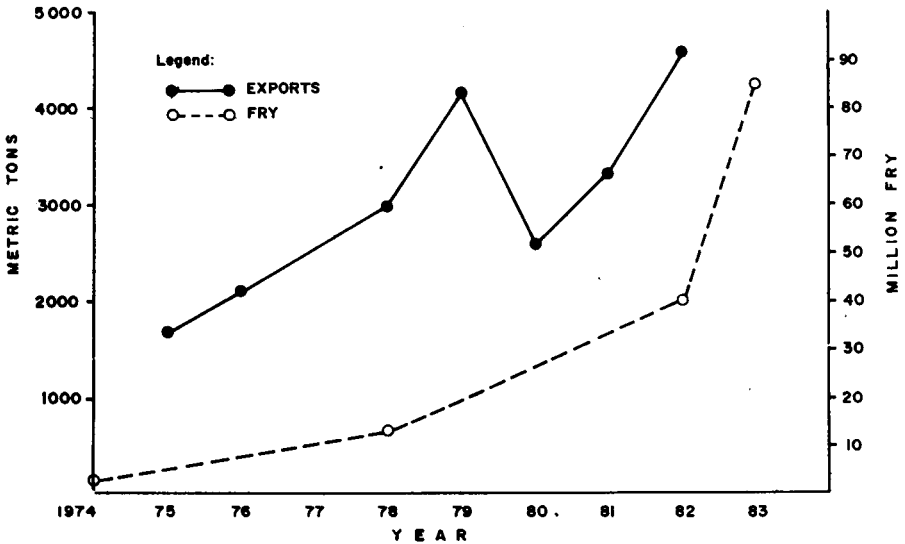

Fig. 3. Total prawn exports and hatchery fry production in the Philippines, 1974-1983.

Fig. 3 shows the gradual but steady increase in hatchery fry production from less than 3 million in 1974 to around 85 million last year (J. Lim personal communication). A rough parallel may be noted in the yearly total prawn exports.

### b. Classification

There are some 60 hatcheries in the country today. A majority (85%) are private owned. The government-operated hatcheries include SEAFDEC AQD hatcheries in Iloilo and Aklan the MSU-southern Philippines Development Authority hatchery in Naawan, Mis. Or., and the Ministry of Human Settlements hatcheries in Mindoro Occ. and Agusan del Norte. More than half (56%) of the hatcheries are located in the Visayas with 24 in Panay Island alone, 21 (36%) are in Luzon and 5 (8%) are in Mindanao.

According to total larval rearing tank capacity in tons and total investment costs, these hatcheries may also be classified into small-scale (less than 30 T tank capacity and less than (P50,000 capitalization), medium-scale (30-100 T capacity and less than P1 million capitalization), and large-scale (above 100 T capacity and at least P1 million capitalization). Based on this classification criterion 10 (17%) are small-scale, 23 (39%) are medium-scale, 12 (20%) are large-scale and the remaining 14 hatcheries are probably small to medium-scale (Fig. 4).

All of these hatcheries rear sugpo but a few have also reared fry of *putian* (*P. indicus* / *P. merguensis*).

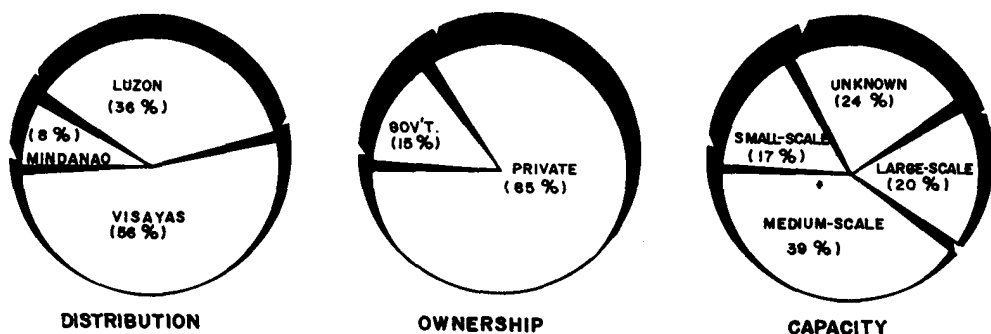

Fig. 4. Classification of prawn hatcheries in the Philippines according to distribution, ownership and capacity (small-scale = 30T and < P50,000; medium-scale = 30-100T and <P1 million capital; large-scale > 100T and >P1 million capital).

**c. Site selection and facilities**

Clean seawater of 28-35 ppt salinity is a primary consideration in locating a hatchery. Seawater supply may be pumped directly from the sea or from a sump pit, an inshore well or seabed using perforated PVC pipes (Quitinio et al 1984).

However, at least two hatcheries are built away from the coastline and had to lay down a few hundred meters of expensive pipeline. A hatchery located in Northern Mindanao that has not produced a single PL in a year of operation was constructed in a mangrove area where salinity drops to 4 ppt.

The case of two hatcheries located inside residential subdivision is noteworthy. Both haul seawater. The owner of one frugally recycles his water while the other claims to have written off a P250,000 tanker he uses for hauling water from the sales of a few million fry.

Besides nearness to seawater, other criteria in site selection include proximity to spawner and broodstock sources, transportation and communications, power supply and freshwater.

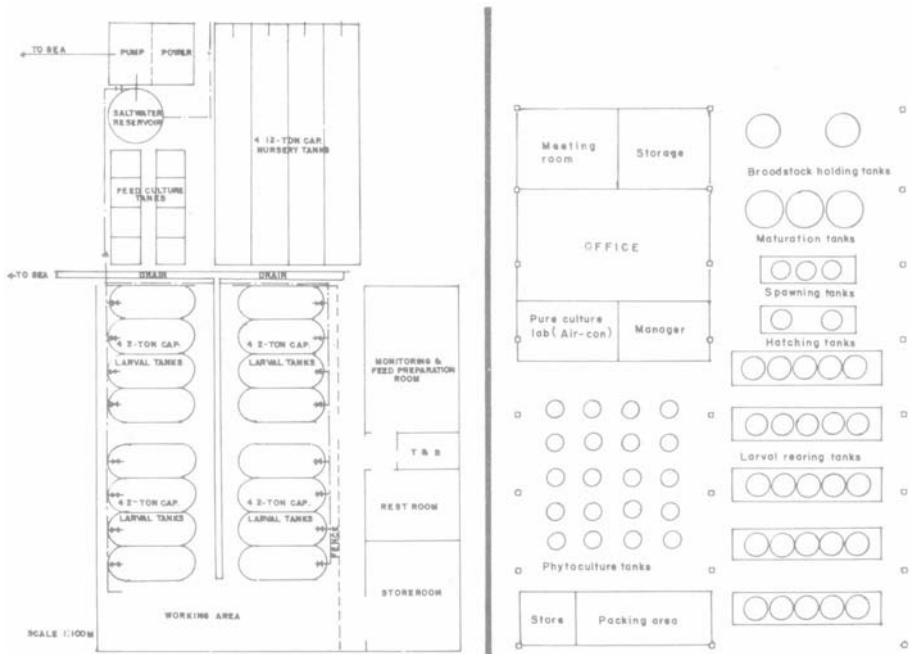

**Fig. 5. Layout of two prawn hatcheries.**

Basic physical facilities include a seawater reservoir, larval rearing tanks, algal tanks and spawning tanks inside a roofed structure (Fig. 5). Optional are an algal room, broodstock tanks, nursery tanks for juvenile rearing and living quarters for live-in staff.

Most hatcheries have their larval tanks and building made of concrete. A cheaper alternative is to use bamboo, plastic sheets and other local materials (Quinitio et al 1984). For the same water capacity, the bamboo hatchery would cost less than P100,000 to build.

**d. Wild spawners and broodstock**

The closing of the life cycle of *P. monodon* and the first rematuration of a spent spawner were achieved in 1975, both by eyestalk ablation (Santiago 1977). In the eyestalk of the prawn are located the production and storage sites of a goad-inhibiting hormone which prevents ripening of the ovaries. In nature, some environmental factors cause the decrease of this substance as the animals migrate from the estuaries back to the offshore areas. Ablation by pinching, cutting or tying of either eyestalk reduces the hormone level so that maturation can proceed (Fig. 6). Continuing produc-

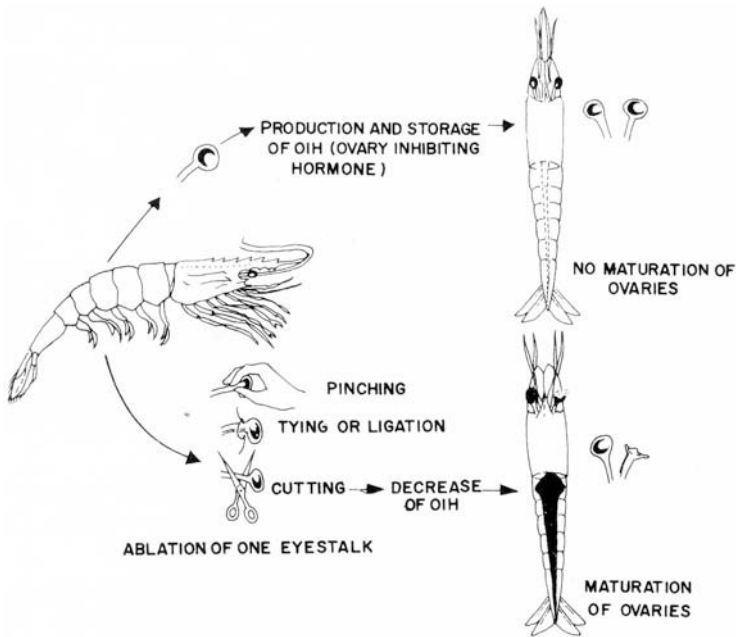

**Fig. 6. Ovarian maturation by eyestalk ablation in sugpo and other prawns.**

tion of the hormone by the remaining unablated eyestalk may explain the reduced fecundity of ablated females (ave. of 300,000 eggs/spawning) compared to wild spawners (ave. 500,000 eggs/spawning).

Hatcheries may use *P. monodon* spawners that are obtained directly from the wild or from captive broodstock with ablated females. Broodstock, in turn, may be pond-reared or wild. Both wild spawners and wild (immature) broodstock are caught by fish traps and filter nets in mangrove areas or by trawler or gill net in offshore areas.

The regular use of pond-reared animals for broodstock to eliminate dependence on wild stock is the ideal target in aquaculture. However, studies

at SEAFDEC AQD and observations by private hatchery operators show that 4 - to 6-month old pond-reared females produce larvae of poor quality after ablation. In contrast, larvae from pond broodstock ablated at 1 to 2 years of age gave relatively higher survival rates (Primavera and Yap 1979).

Given the same body size wild females are older and probably more receptive to induced maturation than normal harvest-age females (Primavera and Yap 1979). In nature, *P. monodon* attains full maturation and spawns for the first time at 10 months (Motoh 1981). Current practice in both research and private hatcheries is the use of wild broodstock for ablation in the meantime that one-year old pond animals are not available on a regular basis.

Once the females are ablated, *P. monodon* broodstock may be maintained in tanks, marine pens, cages or earthen ponds; the latter two systems are still experimental. Land-based tanks may be circular or rectangular, made of concrete or ferrocement, and with water volume of 10-15 m<sup>3</sup>. Salinity, temperature and other environmental parameters are generally dependent on the seawater supply. Maintenance of good water quality whether in a flow-through system or by regular water change in a static system is essential for maturation. A private hatchery controls photoperiod to obtain better maturation results.

The prawns are stocked in batches of 30-40 ablated females and an equal number of unablated males per tank. Sampling for gravid females is undertaken every night using an underwater light. One batch can yield 2 to 10 million nauplii or larvae from six to thirty spawnings over 2 to 6 weeks.

The maturation pen requires a cove for protection against wind and wave action. Seawater should be relatively free from industrial and agricultural pollution. The SEAFDEC model measures 16 x 16 x 4 m and consists of bamboo posts, braces and catwalks enclosed by bamboo matting. Approximately 150 male and 150 ablated female broodstock are kept in an inner polypropylene net resting on the sea bottom.

Feeding is given once to thrice daily at 2-5% of total body weight. Feeds include squid, mussel, marine worms and other items rich in lipids, particularly in certain polyunsaturated fatty acids. Preliminary findings show high levels of those fatty acids in mature ovaries and spawned eggs of wild *P. monodon* spawners and ablated wild broodstock (O. Millamena personal communication). Other details on broodstock tank and pen procedures have been described elsewhere (Primavera 1983a).

All Philippine hatcheries with broodstock maintain them in land-based tanks; the offshore pen is found only in the AQD stations in Batan, Aklan and Igang, Guimaras. This preference may be due to the following advantages of the tank; (a) versatility because it is not site-specific, (b) security against poachers, (c) ease and higher frequency of retrieval of gravid females, (d) convenience in cleaning, and (e) minimal depreciation of concrete tanks compared to bamboo pens (Primavera and Gabasa 1981).

Larval supply of AQD's hatchery tanks has moved from total dependence on wild spawners (1975-76) to the use of females ablated in maturation pens and ferrocement tanks (1977 to present). However, it was only in 1980

that two hatcheries in Mindoro started to operate their own broodstock. Today, 20-25% of all hatcheries in the country depend to some extent on ablated spawners.

In 1975, the year the first sugpo was ablated in the Philippines, one wild spawner cost only P5. Less than a decade later, a wild spawner now fetches P100-700 locally and P15,000-20,000 when smuggled to Taiwan. With the dissemination of SEAFDEC ablation and maturation technology to commercial hatcheries here and abroad, wild broodstock provide a cheaper alternative -- at P20-40 apiece locally and P4,000-6,000 in Taiwan.

The 1983 monthly operating expenses of a hatchery in Roxas City of P30,000 (P9,000 for spawners alone) was reduced by 50% (to P15,000) with a shift to wild broodstock. The availability of ablated females has released the pressure on wild spawners in certain areas like Roxas City. Nevertheless, claiming poor larval quality from ablated spawners, some hatcheries insist on wild ones. A SEAFDEC study this year sets out to prove or disprove this claim.

Transport of nauplii, rather than spawners, in simple, unoxxygenated plastic containers from collecting grounds to the hatchery is another AQD-generated technology adopted by the private sector (Primavera 1983c). This method is also used by hatcheries that would rather sell nauplii to other hatcheries instead of rearing them because of high larval mortalities.

### **e. Larval rearing**

Larval stocking density falls within a high range of 50-100 nauplii/liter in small tanks with a volume of 2-20 tons and a low range of less than 50 nauplii/liter in larger tanks of more than 20 to 200 tons volume.

Hatchery feeding technology may be classified into the fertilized or ecological system and the unfertilized or feeding system (Platon 1979). Developed in Japan, the fertilized method involves the culture of both the larvae and phytoplankton or algal food in the same tank with the latter induced to bloom by the addition of inorganic fertilizer. In the other system, algal food is grown separately and fed at predetermined amounts to the larvae in the feeding system, largely an American innovation. Most Philippine hatcheries shift from one system to the other depending on the quality and quantity of seawater flora which is seasonal.

The kind and amount of food and frequency of feeding varies with the larval stage. Basically however, larval food consists of two items, algae and the brine shrimp *Artemia*. Algae are given from early protozoa up to mysis or even at early postlarvae. These are diatoms (*Chaetoceros calcitrans* and *Skeletonema costatum* and phytoflagellates (*Tetraselmis chuii* and *T. tetrahele*).

Newly hatched brine shrimp nauplii are fed starting mysis up to early postlarvae or even all the way to harvest at PL<sub>20</sub>. An alternative to the natural method of hatching which is cyst decapsulation by sodium hypochlorite or calcium hypochlorite offers the advantages of cysts disinfection, no more separation of nauplii from empty and unhatched cysts, and possible

direct feeding of prawn larvae on decapsulated cysts (Sorgeloos 1977). Nevertheless, private hatcheries prefer natural hatching to decapsulation because the latter involves added processing and fear, whether unfounded or not, of chlorine contamination in the larval rearing tank.

Some hatcheries feed the rotifer *Brachionus plicatilis* during mysis. Early experiments at AQD on the use of frozen, dried or otherwise preserved forms of algae, and rotifers aimed to simplify hatchery operation by concentrating the natural food culture to a single period instead of being a daily activity. Although results showed high survival rates of larvae fed with preserved algae (Millamena and Aujero 1978), the technology has not been picked up by the private sector. In contrast, the use of hard-cooked chicken egg yolk for larval feeding is another Department-generated technology that has been successfully applied by a dozen hatcheries in the country (Gabasa 1982). Egg yolk feeding significantly reduces the live algal food requirement thereby simplifying hatchery technology. Aside from egg yolk, other non-live or processed foods used by government and private hatcheries are yeast, *Artemia* flakes, and the "artificial plankton" B.P. (50-100  $\mu$  particles) as a supplement to or substitute for brine shrimp cysts and A.S. (200-800  $\mu$  particles) for prawn postlarvae. Along this line, Japanese and British companies are developing microcapsulates that range from 50 to 200  $\mu$  in size as partial or complete substitutes for algae, rotifer and brine shrimp.

Water management in larval rearing consists of changing 30% of total volume daily or as the need arises starting from protozoa. All hatcheries have an open water system except for a few that recirculate water through mechanical-biological filters. Most hatcheries operate from March to December when water temperature ranges from 26 to 30°C. When it becomes too cold, some hatcheries seal off the rearing area with plastic sheets to conserve heat and/or use improved 2-kw coil heaters. Other hatcheries have installed thermostatically controlled heaters so they can operate during the cold months when temperature drops to as low as 20°C.

Disease of *P. monodon* larvae and postlarvae are caused by viruses (Baculovirus group), bacteria (*Vibrio*, *Pseudomonas*, *Aeromonas*), fungi (*Lagenidium*, *Haliphthorus*) and ectocommensals (*Zoothamnium*, *Epistylis*) (Lio-Po et al 1981). Disease prevention is through maintenance of good water quality, proper seawater filtration, minimizing of stress, and treatment of spawner with treflan of formalin. Treatment is through the use of tetracyclin, oxytetracyclin, formalin, malachite green, treflan and furanace. Only one private hatchery is known to use antibiotics. This same hatchery also routinely spawns gravid females in seawater with EDIA (ethylenedinitrotetracetic acid), a chelating agent.

### Postlarval/nursery rearing

In response to the high mortality rates of PL<sub>15</sub> to PL<sub>20</sub> in extensive ponds as experienced in the AQD Cooperators Program in 1974, research was initiated to develop a nursery system in ponds and later in tanks. The earthen nursery pond and the nursery tank system have since been adopted by the



private sector. The bamboo slat (banata) substrates first tested in Tigbauan tanks in 1980 are now used by many private nurseries.

Stocking prawn juveniles means higher survival rates and a shorter cropping period in extensive ponds in Northern Panay. With the preference for sturdier juveniles, commercial nurseries using tanks were first established in Roxas City either as independent systems or as part of a hatchery. Many small-scale hatcheries have incorporated the nursery phase within the hatchery complex so that they can sell postlarvae to farmers at the juvenile stage.

Nursery tanks range from 1 to 20 m<sup>3</sup> in capacity. Fry of PL<sub>5</sub> to PL<sub>20</sub> are stocked at 1,000-5,000/m<sup>3</sup> and reared from 2-6 weeks. The postlarvae are fed with *Artemia nauplii*, mussel meat, trash fish and others. Substrates made of bamboo slats, polypropylene net, nylon material or plastic sheets are installed to provide increased surface area. In addition to shelter from predation and cannibalism, the substrates grow benthic algae and associated animals which become additional food for the prawns. Survival of prawn postlarvae with different substrates was significantly higher than those reared without substrates (Martosudarmo 1983).

In general, survival rates in nurseries are higher than in larval rearing tanks because rearing beyond PL<sub>5</sub> is more predictable than the larval stages of protozoa and mysis.

#### **g. Harvest, transport and marketing**

Hatcheries in Cebu, Mindoro and elsewhere that fly their fry to other island do not harvest beyond the PL<sub>25</sub> stage. At this size, the fry are small enough to be packed at high densities with minimal risk compared to juveniles with a greater biomass. Moreover, intensive and semi-intensive ponds with more efficient methods of predator control than in extensive ponds may stock young PL<sub>25</sub>.

Packing procedures depends on the size or age of fry and duration of transport. Fry transported by air are packed at 5,000-10,000 PL<sub>20</sub>/bag, each polythylene bag containing 8-10 liters of seawater with oxygen added and temperature decreased to 21-24 C. The plastic bags are placed inside styrofoam boxes with or without an outer G.I. container.

Juveniles transported overland to prawn ponds are packed at 500-2,000/bag which in turn is placed in a styrofoam box or buri bag. If transported for a short period during early morning or at night when it is cool, no temperature lowering and oxygenation are needed. Longer transport time requires oxygen, temperature decrease and lower stocking densities.

A growing trend among hatcheries and nurseries is to acclimate the fry prior to transport to salinity levels close to those of the receiving pond. This minimizes the acclimation period in the ponds so that the postlarvae or juveniles can be stocked soon after arrival.

While hatchery fry may travel directly from hatchery to grow-out pond the route of wild fry is longer; it goes through a concessionaire sub-dealer and dealer before reaching the farmer (Fig. 7). The additional steps mean

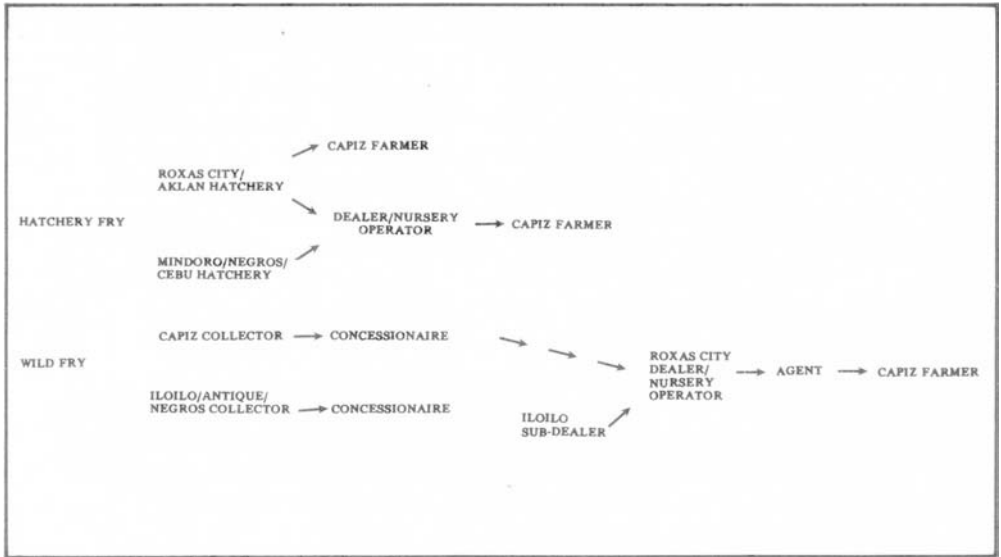

Fig. 7. Marketing channels of sugpo (*Penaeus monodon*) fry.

From: Primavera, J.H. 1983. *Prawn Hatcheries in the Philippines*. Asian Aquaculture, May June 1983.

greater stress for the fry. Such stress coupled with the availability in limited quantities and varied sizes of wild fry account for the growing preference among farmers for hatchery-reared fry.

Although prawn ponds are generally supplied by hatcheries within the same area, the relative shortage has led to a movement of fry towards the two major prawn-growing areas: Northern Panay and Central Luzon. Cebu has few prawn ponds and most of its hatchery production goes to other islands facilitated by the numerous flights out of Mactan Airport.

## PROBLEMS

If we assume: (a) density of 50 larvae/liter, (b) 30% survival from larvae to PL<sub>5</sub>, (c) 50% survival from PL<sub>5</sub> to juveniles, (d) 10 operational months/year, (e) 2 larval rearing runs/month, (f) average larval rearing capacity of 20 tons (20,000 liters), 50 tons and 400 tons for small, medium and large-scale hatcheries, respectively and (g) operational capacity of 75% for small-and medium-scale and 50% for large-scale hatcheries, what is the total potential hatchery production?

Based on these, we come up with 2.2 million, 5.6 million and 30 million juveniles each that could be produced annually by the small, medium, and large-scale hatcheries, respectively. Multiplying this by the number of hatcheries, we should have a total potential production of over 500 million juveniles. Without including the 14 unclassified hatcheries, it is clear that the reported 1983 hatchery production of around 35 million was way below this estimated potential.

What problems plague our hatcheries to account for underproduction? Among the non-technical problems, two are foremost: lack of spawners and lack of technicians. In a sense, as long as larval survival is unpredictable, spawners will always be in short supply.

The export of sugpo spawners to Taiwan is a yearly multimillion peso industry. With numerous hatcheries (500 of one count) and not enough spawners, Taiwan must look to her Southeast Asian neighbors with their abundant natural stocks of *P. monodon*. The Philippines, in particular, has been a favorite collecting ground because of its proximity. An hour's flight from Taiwan by private plane, Aparri in the North is a major exit point aside from the international airports in Manila, Cebu and Zamboanga.

Some Philippine hatcheries started out as holding stations for wild spawners en route to Taiwan. Only later did these stations undertake serious larval rearing activities. Aware of the massive outflow of spawners (as many as 200-300 in one day), researchers at SEAFDEC AQD recommended that the government ban spawner export in order to protect our own infant hatchery industry. In December 1982, Fisheries Administrative Order No. 141 "banning the export of live gravid shrimps of the genus *Penaeus*" was jointly issued by the Ministry of Natural Resources and the Bureau of Fisheries and Aquatic Resources finally making the export illegal. Even then, the trade continued, branching out into wild broodstock. This promoted the MNR to issue F.A.O. No. 143 a year later extending the ban to "all live prawns of the species *Penaeus monodon*". Still the smuggling goes on.

The technician is the most important resource in a hatchery as long as larval rearing remains more an art than science and fry survival hinges on the skill of the technician. The spectrum of hatchery manpower in the Philippines starts from zero technician (hatchery not operating) to second and third-rate technicians (hatcheries under-productive) to first-rate technicians (hatchery successful, given the other requirements). Recently, salaries have ranged from P2,000 to P6,000 for Filipino technicians and P10,000 or more for Taiwanese technicians. Nevertheless, not even a high salary can keep a good technician nor assure the success of a hatchery. Many successful Taiwanese hatcheries are run as family affairs with the larval rearing techniques, the secrets of the trade, so to speak, handed from one generation to the next.

It is this "state-of-the-art" status, the lack of definition of water quality, and other rearing parameters that make erratic survival rates unexplainable. Among the few factors that have so far been quantified are salinity and temperature - eggs will not hatch and larvae will not molt below 28 ppt (Reyes 1981). This explains the non-production of the hatcheries in Northern Mindoro located in a low-salinity mangrove area. The remaining variables need further experimental work. Other industry problems include the scarce supply and prohibitive prices (P1,200/tin of 400 grams) of *Artemia* cysts and lack of capital or subsidy.

## **POLICY RECOMMENDATIONS**

### **a. Resource survey**

Although the basic technology in ablation of wild broodstock, larval

rearing, and nursery has been extended to the private sector, the following areas for experimental work remain:

1. Maturation of pond-reared broodstock as long-range solution to the problem of spawner supply.
2. Development of alternatives to ablation, e.g. hormones and nutrition to induce ovarian maturation.
3. Studies on larval quality, algal feeds, disease and other factors that may affect survival rates.
4. Refinement and/or development of egg yolk feeding, microcapsules, etc. to reduce if not eliminate live algal food requirements.
5. Local production of *Artemia* cysts in salt ponds.
6. Development of *Artemia* substitutes in larval rearing such as *Moina* and other zooplankton species
7. Refinement of nursery tank techniques.

b. **Conservation of wild spawners**

Smuggling of spawners can be minimized by:

1. More strict enforcement of F.A.O. No. 143. Corollary to this is the training of BFAR and other personnel assigned to international airports in the identification of different prawn species, spawners vs. broodstock, and fry vs. nauplii.
2. Extension of the coverage of the ban to include all species as well as nauplii transport.
3. Requirement of government licenses or permits for buying wild spawners with accreditation from local fishfarmers' associations to monitor wild spawner catches and movements.

c. **Research directions**

To maximize utilization of wild fry, broodstock and spawners, BFAR and other government agencies should undertake surveys to identify collecting grounds all over the country. Once these areas are mapped out, local fishermen should be trained in the collection, identification, holding, packing and transport of wild prawn fry, broodstock and spawners. (An example of such a training was the April 26-27, 1984 symposium in Zamboanga City sponsored by SEAFDEC, BFAR and the Zamboanga Fry Dealers Association.)

d. **Training of technicians**

Increase in the number and improvement of the quality of prawn hatchery technicians can be achieved through:

1. Extension of hatchery training programs to at least 6-10 months to cover larval rearing runs.
2. Development of a system of accreditation of qualified technicians to protect unsuspecting hatchery owners from "charlatans" of the industry.
3. Offering of refresher courses for technicians who are operating hatch-

- ries continuously beset by problems of larval mortalities, etc.
4. Providing extension services to hatcheries in the form of algal starters, disease diagnosis. An experienced SEAFDEC AQD hatchery specialist has been assigned the fulltime job of troubleshooting problem hatcheries.
  5. Recruitment of a greater number of technicians by SEAFDEC, MSU and other government hatcheries to allow for pirating of technicians by industry.

e. **Other recommendations**

1. Soft loans TRC, ADB, World Bank-IFC, etc. to subsidize construction and operating expenses of prawn hatcheries.
2. Tax exemption of *Artemia* cysts and other imported hatchery supplies and equipment and their classification as basic raw material.
3. Clearinghouse for prawn fry buyers and producers. Lastly, we must diversify markets and diversify species to include white shrimps locally known as putian (*Penaeus indicus* and *P. merguensis*). Lighter-colored white, pink and brown prawns and shrimps have an unlimited market abroad, constituting 60-80% of total consumption in Japan and the USA, and an assured local market. Spawner supply and larval rearing of these species are easier than for sugpo but production of export-sized prawns (at least 20 g or 50 pcs to a kilo heads-on) from grow-out remains an area for further research.

## REFERENCES

- Gabasa, P.G. 1982. Recent developments in design and management of small-scale hatchery for *Penaeus monodon* in the Philippines. SCS/GEN/82:40, pp. 77-86.
- Lio-Po, G., Tamse, C.T., Baticados, M.C.L. and E.R. Cruz. 1981. Prawn disease prevention and control. Small-Scale Prawn Hatchery Management Training, SEAFDEC Aquaculture Dept., Tigbauan, Iloilo (mimeo).
- Martosudarmo, B. 1983. Effects of different substrates and selected feeds on the growth and survival of hatchery-produced *Penaeus monodon* postlarvae. U.P. Visayas. Unpub. M.S Thesis 83 pp.
- Millamena, O. and E. Aujero. 1978. Preserved algae as food for *Penaeus monodon* larvae. SEAFDEC Aquaculture Dept. Quarterly Report 2:15-16.
- Motoh, H. 1981. Studies on the fisheries biology of the giant tiger prawn, Aquaculture Dept., Iloilo, Philippines, 128 pp.
- Platon, R. 1978. Design, operation and economics of small-scale hatchery for larval rearing of sugpo, *Penaeus monodon* Fabricius. Extension Manual No. 1, SEAFDEC Aquaculture Dept., Iloilo, Philippines. 330 pp.
- Platon, R. 1979. Prawn hatchery technology in the Philippines. Technical Consultation on Available Aquaculture Technology, Tigbauan, Iloilo 8-11 Feb. 1979, pp. 128-138.
- Primavera, J.H. 1983. Broodstock of sugpo (*Penaeus monodon* Fabricius). Extension Manual No. 7, SEAFDEC Aquaculture Dept., Iloilo, Philippines, 25 pp.
- Primavera, J.H. 1983b. Broodstock technology and the prawn industry. Greenfields 13:21-23.
- Primavera, J.H. 1983c. Prawn hatcheries in the Philippines. Asian Aquaculture 5:1-4,6:5-8.
- Primavera, J.H. and P. Gabasa Jr. 1981. A comparison of two prawn (*Penaeus monodon*) broodstock systems -- land-based tanks and marine pens. J. World Maricul. Soc., 12:345-356.
- Primavera, J.H. and W.G Yap. 1979. Status and problems of broodstock and hatchery management of sugpo (*Penaeus monodon*) and other penaeids. PCARR Symposium on Fish Hatchery Nursery Management, Metro Manila, 27-28 Sept. 1979 (mimeo).
- Quinitio, E., P. Gabasa, Jr., F. Sunaz, D. de la Peña, Jr., D. E. Reyes, and R.

- Rivera. 1984. A guide to prawn hatchery and operation. Extension Manual No. 9, SEAFDEC Aquaculture Department. (in press).
- Santiago, A.C. Jr. 1977. Successful spawning of cultured *Penaeus monodon* Fabricius after eyestalk ablation. Aquaculture 11:185-196.
- Sorgeloos, P., et al. 1977. Decapsulation of *Artemia* cysts: A simple technique for the improvement of the use of brine shrimp in aquaculture. Aquaculture 12:311-316.
- Villaluz, D.K., Villaluz. A., Ladrera, B., Sheik, M. and A. Gonzago. 1972. Reproduction, larval development and cultivation of sugpo (*Penaeus monodon* Fabricius). Philipp. J. Sci, 98:205-234.
- Villaluz, A.C., U.R. Villaver, and R.S. Salde. 1982. Milkfish fry and fingerling industry of the Philippines: Methods and practices. SEAFDEC Aquaculture Department Technical Report No. 9, 84 pp.

## PENAEID PRAWN HATCHERIES IN THE PHILIPPINES

Enterprise/Owner	Location	Management	Capacity <sup>a/</sup>	Remarks
1. Cagayan State University (CIADP)	Aparri, Cagayan	Govt.	SS	Not operating
2. Taggat Industries Mr. Alfonso Lim	Claveria, Cagayan	Pvt.	MS	
3. Vice Gov. Godofredo Reyes	Sta. Maria Ilocus Sur	Pvt.	MS	
4. Vice Mayor Samuel Bautista	Binmaley Pangasinan	Pvt.		
5. Mr. Romualdo Mascarinas	Limay Bataan	Pvt.		
6. Mayor Serafin Roman	Orani, Bataan	Pvt.	SS	Not operating
7. Naic Aqua Corp/ Mr. Richard Ty	Naic, Cavite	Pvt.	MS	
8. Yoshimine Aquatic Dev. Corp/Marcos Andrin	San Juan Batangas	Pvt.		
9. Mr. Earl Kennedy	Parañaque Rizal	Pvt.		Hauls seawater
10. Mr Angel Virri	Parañaque	Pvt.		
11. Min. Human Settlements	Mamburac, Mindoro Occ.	Govt.	MS	
12. Masaganang Sakahan, Inc.	Magsaysay, Mindoro Occ.	Govt.	LS	
13. Aquafil/Tabacalera	San Jose Mindoro Occ.	Pvt.	LS	
14. San Jose Aquaculture Dev. Corp/Mr. Alfonso Lim	San Jose Mindoro Occ.	Pvt.	LS	
15.	Masbate, Masbate	Pvt.	SS	

<sup>a/</sup> SS — small scale; MS - medium scale; LS — large scale



16.	Suarez Agro Ind. Corp/ Mr. Danilo Suarez	Catanawan Quezon	Pvt.	MS	
17.	Licup, Ian & Co.	Pagbilao, Quezon	Pvt.	-	Not operating
18.	Mr. Vicente Go	Gumaca, Quezon	Pvt.		Not operating
19.	LYL Marine Ind. Corp./ Mr. A. Lim Yuc Long	Daet, Camarines Norte	Pvt.		
20.	River, Land & Sea Dev. Corp./Mr. Rolando Sianghio	Paracale, Camarines Norte	Pvt.		Not operating
21.	Fiesta Hatchery/Messrs. de Guzman & Enrile	Tinambak, Naga, Camarines Sur	Pvt.		Not operating
22.	SEAFDEC AQD	Batan, Aklan	Govt.	MS	
23.	Mega Hatchery	Batan, Aklan	Pvt.	MS	
24.	Reyes Backyard Hatchery Mr. Reynaldo Reyes	Batan, Aklan	Pvt.	MS	
25.	Rojas Prawn Hatchery Mr. Luis Rojas, Jr.	Obob, Batan, Aklan	Pvt.	MS	
26.	Rojas Prawn Hatchery Mr. Luis Rojas, Jr.	Batan, Aklan	Pvt.	MS	
27.	Aquamarin Hatchery Co.	Dumaguait, Aklan	Pvt.	MS	
28.	Pacific Aqua Dev. Corp. Mr. Mike Ho	Makato Aklan	Pvt.	LS	
29.	AA Export Aqua Dev. Corp. Mr. R. del Rosario	Makato Aklan	Pvt.	LS	
30.	Shrimpy's Hatchery Ms. Nilda Bermejo	Baybay, Roxas City	Pvt.	LS	
31.	Atty. Antonio Ortiz	Baybay, Roxas City	Pvt.	SS	

32.	Anvil Hatchery/Mr. Vicente Andaya	Baybay, Roxas	Pvt.	MS	
33.	Mr. Santiago Bermejo, Jr.	Roxas City	Pvt.		
34.	TV Fish Marketing Mr. Antonio Tan	Punta Tabok, Roxas City	Pvt.	MS	
35.	Mr. Hock Sing	Baybay, Roxas City	Pvt.	SS	
36.	San Rafael Aquaculture Atty. Rafael Dinglasan	Baybay, Roxas City	Pvt.	MS	
37.	Cogor Aquafarms Atty. Rafael Dinglasan	Cogon, Roxas City	Pvt.	MS	
38.	JBL Corp./Mr. John Whang	Cogon Roxas City	Pvt.	MS	
39.	Venus Hatchery Mr. Dam Arches	Cogon, Roxas City	Pvt.	MS	
40.	Mercury Hatchery Mr. Dam Arches	Dumalag, Roxas	Pvt.	MS	
41.	Emma Hatchery Maj. & Mrs. Manuel Soriano	Carles, Iloilo	Pvt.	MS	
42.	SEAFDEC AQD	Tigbauan, Iloilo	Govt.	LS&SS	
43.	SEAFDEC AQD	Leganes, Iloilo	Govt.	MS	
44.	Mr. D. Villaluz	Leganes, Iloilo	Pvt.	MS	Not operating
45.	Mr. Nelson Jamandre	Oton, Iloilo	Pvt.	MS	
46.	Ms. Dawn Jamandre	Oton, Iloilo	Pvt.	MS	Not operating
47.	Seascape Hatchery Mr. Te Bon Eng	Villa, Iloilo	Pvt.		
48.	Blue Crest Aquafarms Mr. Te Bon Eng.	Dumangas	Pvt.		

48.	Blue Crest Aquafarms Mr. Ricardo Gulanes	Dumangas	Pvt.		
49.	Phil. Marisco Corp.	Calumangan Bago City	Pvt.		
50.	Pioneer Hatchery Mr. Franklin Yung	Punta Taytay Bacolod City	Pvt.		
51.	Macopa Fry Resources Mr. Gerardo Lopez, Jr.	Sto. Clara Subdv. Bacolod City	Pvt.		
52.	San Miguel Corp.	Calatrava Negros Occ.	Pvt.	LS	
53.	HJR Fishing Ind. Mr. Jerry Lim	Banilad Cebu City	Pvt.	LS	Hauls seawater
54.	HJR Fishing, Inc. Mr. Jerry Lim	Liloan Cebu	Pvt.	LS	
55.	Premier (Ocean Life) Matchery/Mr. Jimmy Uy	Talisay Cebu	Pvt.	LS	
57.	St. Paul's Farms Mr. Francisco Tan	Ormoc Leyte	Pvt.	MS	
58.	Min. Human Settlements	Cabadbaran, Agusan	Govt.	SS	Not operating
59.	MSU-Southern Phil. Dev. Authority	Naawan, Govt.	LS		
60.	Mr. Pedrito Bombeo	Panaon Misamis Occ.	Pvt.	MS	
61.	Mr. Luciano Puyod	Davao City	Pvt.	SS	Not operating
62.	Zamboanga Regional Inst. Fish. Tech.	Zamboanga City	Govt.	MS	



# EXTENSIVE AND SEMI-INTENSIVE CULTURE OF SUGPO (*Penaeus monodon*) IN THE PHILIPPINES

Florentino D. Apud  
Researcher  
SEAFDEC Aquaculture Department

## INTRODUCTION

The significant events in the history of pond cultivation of jumbo tiger prawns known as *sugpo* in the Philippines could be placed within the last three decades. The earliest account regarding its pond culture separately or with milkfish was written by Villadolid and Villaluz (1950). In "Fish Farming in the Philippines," Villaluz (1953) described its morphological characteristics, feeding habits, preparation, stocking and care of fry in nursery pond and preparation of rearing pond.

A study on its growth rate conducted by Delmendo and Rabanal at the Dagatdagatan experimental ponds of the Philippine Bureau of Fisheries was published in 1956. In 196b, Villaluz wrote an information leaflet entitled "General Information on Shrimp (*Sugpo*) Cultivation in the Philippines." In a review paper presented at the FAO World Scientific Conference on the Biology and Culture of Shrimps and Prawns, Caces-Borja and Rasalan (1968) discussed sugpo fry collection and marketing, pond culture, and problems associated with its cultivation in monoculture and in polyculture with milkfish.

Feedbacks and lectures given by some fishery officials who had gone abroad to observe prawn culture activities particularly in Japan and Taiwan in the early sixties have intensified interest and enthusiasm in the government and in the private sector to develop the *sugpo* industry. The ever increasing demand for said prawns in the international market triggered greater interest.

For many years the industry had suffered major setbacks in pond culture due to inadequate and unreliable supply of prawn fry from the wild (Delmendo and Rabanal 1958; Caces-Borja and Rasalan 1967; Villaluz *et al* 1969). The breakthrough in the mass production of prawn fry at MSU-IFRD, Naawan, Misamis Oriental (Villaluz *et al* 1969) under controlled hatchery conditions marked the take off point in the development of the industry. With this achievement, many fishpond operators felt assured of fry supply and were encouraged to go into *sugpo* culture.

The 1970s saw more intensified research activities in hatchery and pond culture techniques, training and extension programs, and more involvement by both the government and the private sector in the development of the industry. The MSU-IFRD and SEAFDEC Aquaculture Department spearheaded the research, training and extension activities in collaboration with the Bureau of Fisheries and Aquatic Resources, Philippine Federation of Aquaculturists and some fishfarmers.

## PRODUCTION, MARKET DEMAND, AND CULTURE METHODS

### a. **Production and Market Demand**

According to the Market Report Vol. 3 of ADB/FAO Infofish. 1982, the Japanese shrimp consumption in 1981 was 199,000 metric tons. Out of this volume, about 161,700 metric tons were imported from different countries (Japan Finance Ministry and U.S. Dept. of Commerce). The Philippines contributed about 2,700 metric tons or only 1.7% of Japan's total import. This quantity declined considerably from the 1979 record of 3,700 metric tons exported to Japan. About one-half of the export in 1979 was captured from the sea, the rest was pond-grown.

The major cause in the decline of prawn and shrimp export could be attributed to a drastic reduction in the volume of catch. BFAR reports that the catch of prawns and shrimps in 1981 was only 723 metric tons. Based on this figure, it appears that the volume of pond-grown shrimp for export slightly increased from 1,850 metric tons in 1979 to 1,977 metric tons in 1981. Assuming an average production of 250 kg/ha/yr using extensive culture method, such volume could be derived from only 7,600 ha of brackishwater fishponds in the Philippines. If the same farms were used in semi-intensive culture producing a minimum of 750-1,000 kg/ha/year, output from the same area could be twice or thrice the present volume.

### b. **Culture Methods**

Generally, the fishpond yield per unit area is dependent on the culture method which could be restricted by financial capabilities, pond facilities, level of technical knowhow, and skill. If the culture method does not take into account these factors, failure is highly possible.

The SEAFDEC Aquaculture Department has categorized culture methods into three: extensive, semi-intensive and intensive. The extensive method is commonly practised by fishfarmers and is generally applied in less developed farms or in existing milkfish ponds. These ponds are generally shallow (40-70 cm) with only one gate to serve as supply and drain facility. *P. monodon* under this method are stocked at limited quantities (2,000-3,000 ha) in monoculture or in polyculture with milkfish. The stock are fully dependent on natural food propagated by fertilization. Water management is totally dependent on tidal fluctuation. Efforts are being made to provide a deeper portion that is suitable for prawns by constructing peripheral or diagonal canals. Pests and predators are also eradicated during pond preparation. Their entrance are prevented by providing fine-mesh screen at the gate system during water replenishment.

The semi-intensive culture method has a higher stocking density ranging from 20,000 to 50,000 per ha. Supplemental feed is provided to the stock in addition to natural food. The shallow pond is excavated to attain 70-100 cm water depth, otherwise a trench is constructed to provide a deeper portion of at least 20% of the area. To provide the desired water quality and

depth, a water pump is operated especially during neap tide. A number of fishfarmers have shifted to this method to increase yield.

The intensive culture method is basically patterned after that of Taiwan where stocking density has been raised between 100,000 to 200,000/ha. The pond facilities normally include concrete or bricklined dike of small compartments (1/4 to 1 ha); water pumps that provide a pre-filtered mixture of fresh and seawater at appropriate salinity of 10-20 ppt; and aeration devices to provide oxygen, release toxic gases and mix water 24 hours a day. The stock is fully dependent on a high-grade formulated diet. So far very few big investors have adopted this method because of higher capital requirement, higher level of technology, and high risks.

Of the three culture methods, the extensive appears to be most widely practised. The semi-intensive method, however, appears to be the most viable and easily adaptable. The discussion therefore shall be confined to extensive and semi-intensive culture of prawns.

## **EXTENSIVE AND SEMI-INTENSIVE CULTURE OF PRAWNS**

### **a. Rearing in nursery system**

Direct stocking of fry in grow-out ponds, both with extensive and semi-intensive culture of prawns, is considered most convenient by fishpond operators. Results have been unreliable so that an intermediary pond has to be used. At first, the milkfish nursery pond was utilized for prawn fry using the same management method as for milkfish fry culture. This method, however, can hardly achieve acceptable rates of survival. As skill and knowhow developed, different nursery systems were designed to improve prawn fry survival. These include the use of hapa net and the floating cage nursery, the earthen nursery, and the tank system.

#### **(1). Hapa net and floating cage nursery system**

The hapa net was introduced in 1975 (Primavera and Apud 1977) primarily as an acclimation facility and secondarily as a nursery system for sugpo fry. The rectangular nylon net (Fig. 1A) is similar to an inverted mosquito net set in a pond. It is suspended from bamboo or wooden poles and sometimes enclosed with bamboo screen to protect it from crabs. It is normally installed near the supply gate for better water exchange.

The floating cage as a nursery facility (Fig. 1B) is a recent development initiated by de la Peña and Prospero (1982) at AQD's Batan Station. The floating cage is appropriate in coves with slow currents, protected from big waves, and with minimum fluctuation in salinity, temperature, D.O. and pH. The cage is made of fine mesh net with a coarse outer net or bamboo enclosure for protection. The net is hung on a bamboo or wooden frame provided with floating materials. A 3 x 4 x 1.2 m net cage can accommodate some 25,000 to 30,000  $P_4 - P_5$  for a rearing period of 30 to 40 days. Feed-

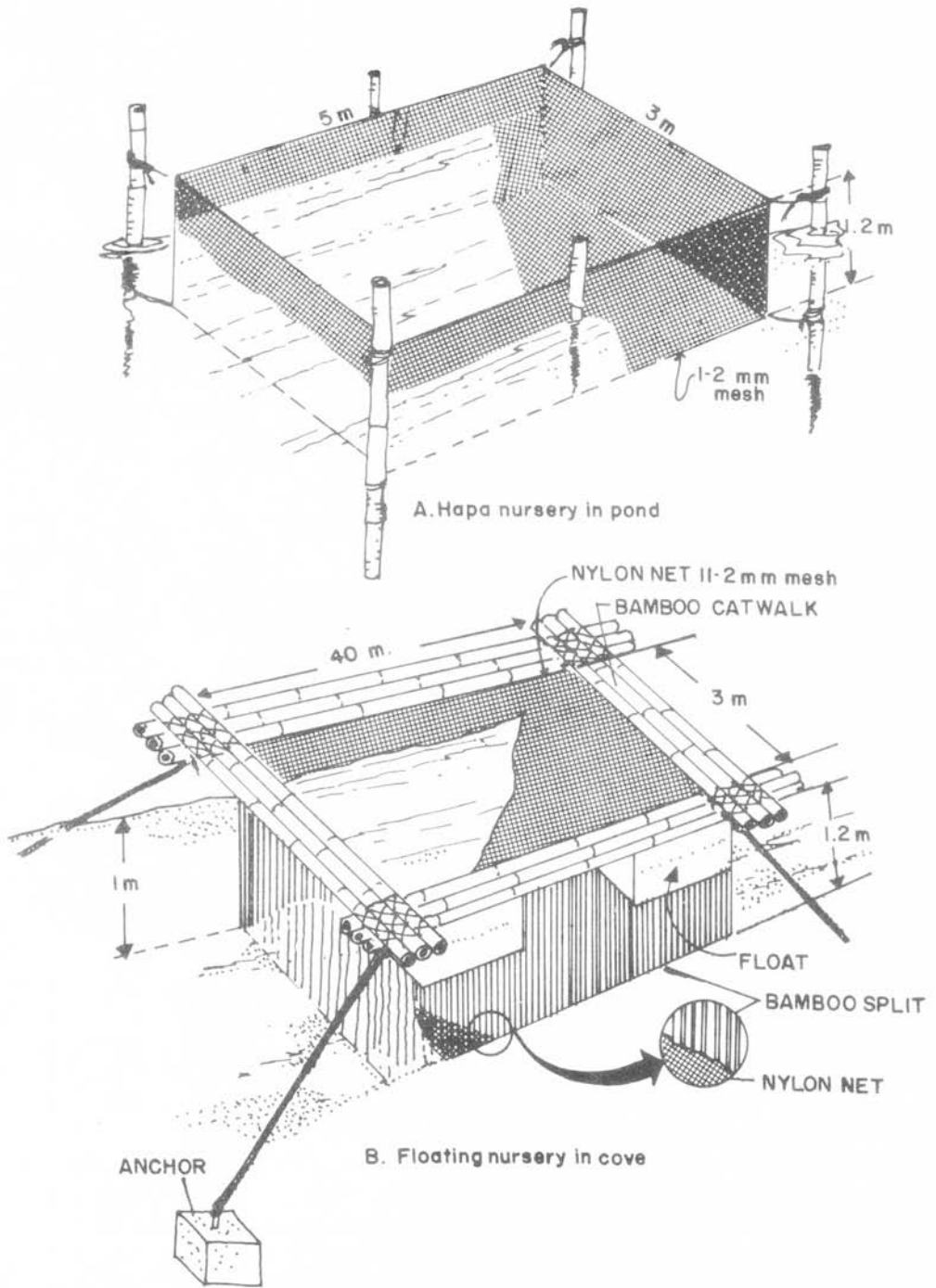

**Fig. 1. Floating or hapa net nursery can stock 30,000-40,000 postlarvae/net, is easy to install in a pond (A), or marine cove (B).**



ing is done initially by brushing prepared fish paste in a feeding net frame. At the P<sub>4</sub> - P<sub>5</sub> stage, fry tend to cling to any substrate, so that they cling to the feeding frame and feed at the same time. Starting at P<sub>11</sub>, feeding is shifted to chopped fish or mussel meat attached to a series of hooks hanging from a floating frame. A survival rate of 50 to 70% can be attained.

## (2) *Earthen nursery system*

The earthen prawn nursery system (Fig. 2) was developed at the SEAFDEC Leganes Research Station (Apud and Sheik 1978) to accommodate hatchery-bred fry even at earlier stages (P<sub>4</sub>-P<sub>5</sub>) and rear them to desirable sizes (0.4-1 g) or stages (P<sub>34</sub>-P<sub>35</sub>) suitable for stocking in grow-out ponds. Management of the system aims at controlling excessive fluctuations in temperature, salinity dissolved oxygen, and pH and having a maximum control of pests and predators. These are achieved through a flow-through system with a daily water exchange rate of about 10% and the use of sand filter or fine mesh filter net for water flowing into the ponds.

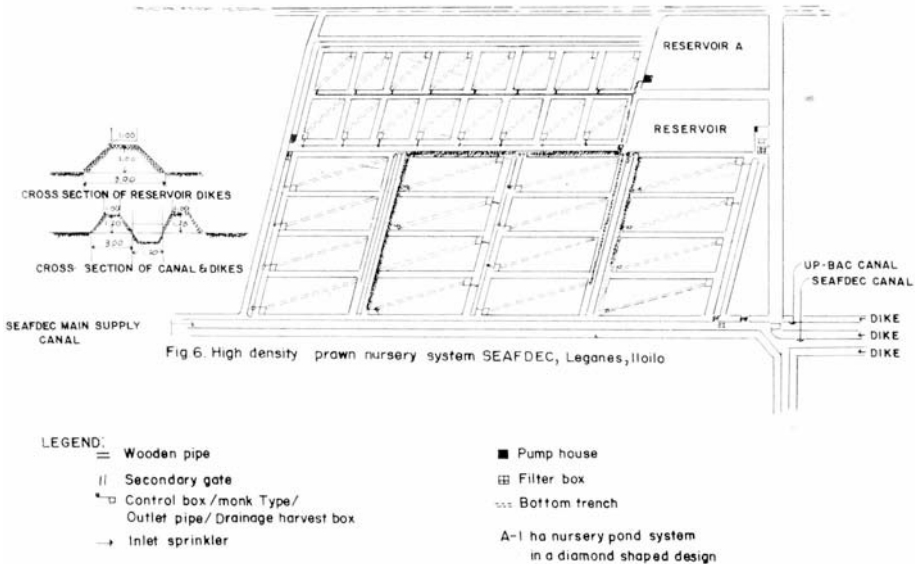

**Fig. 2. High density prawn nursery system SEAFDEC, Leganes, Iloilo.**

The nursery ponds may be stocked at densities of 50 to 100 per m<sup>2</sup> without supplementary feeding. With supplementary feeding (trash fish, mussel meat, or formulated feeds) the density can be as high as 150 to 200 P<sub>5</sub> per m<sup>2</sup>. Acclimation of prawn fry to pond water conditions is necessary during stocking. The proper time for stocking is early in the morning (before 9:00 A.M.) or late in the evening (after 9:00 P.M.). Juveniles at stages

P<sub>34</sub> - P<sub>35</sub> weighing about 0.4-1.5 g a piece are harvested after 30 days rearing period. The recommended time of the day for harvest is during the evening or early morning. Survival rates may range from 40 to 80% .

### (3) **Tanks or raceways**

Tanks or raceways are practicable in areas with available electric power to drive water pump and blower that provides aeration. The raceway system was tried by Platon (1978) in rearing P<sub>1</sub> - P<sub>2</sub> fry to P<sub>13</sub>. The raceway is a 1-2 ton oval tank with airlift aeration to circulate the water. Bamboo mattings to serve as shelter are also provided. At stocking density of 5,000/m<sup>3</sup>, an average survival rate of 50% is obtained. The fry is fully dependent on supplemental feed.

The use of nursery tanks integrated in hatchery system was initiated by Gabasa (1981). Tanks are usually of concrete and vary in size from 3 to 40 tons. Stocking densities vary from 2,500 to 3,000 per ton with culture period of 30 days from P<sub>1</sub> - P<sub>2</sub> or P<sub>4</sub> - P<sub>5</sub>. The tanks are provided with bamboo mattings as shelter. Fry survival has been very much improved (70-90%) with this system. The fry in tanks are highly dependent on supplementary feeding although growth of diatoms is also encouraged.

### (4) **Transport of juveniles**

Prawn juveniles harvested from any of the facilities mentioned above may be transported using a continuously aerated transport tank or oxygenated plastic bags. The aerated tank is made of a cylindrical fiber glass, plastic or canvass. The recommended capacity is 30 kg juveniles/ton of water (Mochizuki 1978). For better results, the temperature of transport water is reduced to 22-24 C and maintained at this temperature by adding ice from time to time.

For transport using oxygenated plastic bags, the juveniles are climated gradually to about 20 C using ice mixed with seawater. The temperature of sand-filtered seawater to be used for transport is also reduced to 20°C. The juveniles are packed in plastic bags containing 8-10 liters seawater inflated with oxygen at recommended densities of 1,000 to 2,000 P<sub>25</sub> - P<sub>35</sub> per plastic bag. The bags are placed singly or doubly in styrofoam boxes. To maintain temperature at the desired level, packed ice weighing 500 to 600 g is placed on top of each plastic bag.

Yap *et al* (1978) tried using different packing densities of juveniles transported in oxygenated plastic bags for a period of 15 hours. The density levels tested were 1,000; 2,000; 3,000; 4,000; and 5,000 P<sub>26</sub> per bag. A pack of 600 g ice was placed on top of each bag; 400 mg prawns could be packed and transported as much as 3,000/bag for 15 hours. The temperature of transport was maintained at 22-23 C and survival was 95-100% . Packing densities of .4,000 to 5,000 suffered higher mortalities (from 12.5 - 50%). The latter densities could be used only for shorter transport periods.

## b. **Culture in Growout Ponds**

The pond culture of *sugpo* in the Philippines has evolved slowly through years of experience by fishfarmers. For many years, *sugpo* was an incidental harvest from milkfish ponds. Because of the ever increasing demand, more efforts have been directed to develop *sugpo* as a major crop in brackishwater ponds. In the process of development, several factors that influence prawn production have been pointed out. These include site suitability, pond design and construction, seed supply, pest and predator control, stocking densities, food supply, diseases and parasites, water management, and harvesting.

### (1) Site Suitability

The major factors known to influence prawn production in certain areas include climatic condition, water supply, type of soil, topography, accessibility, availability of labor and material inputs, and support facilities. Better production has been observed in areas with a short and not-so-pronounced dry season with moderate rainfall distributed almost throughout the year. Suitable areas are those having sufficient supply of water that is free from pollutants and with a salinity of 10-20 ppt and those with soil pH between 7-8.5, of either the clay-loam type of soil, silty clay, silt loam that is good for dike construction, or sandy clay that suits the creeping and burrowing habit of *sugpo*. Pond elevations are within the reach of ordinary high tides where a water depth of 1 meter can be easily attained. Areas with high elevation require considerable expense for excavation or water pumpings. Accessible areas facilitate supervision and delivery of inputs and products. The presence of support facilities such as electric power plant and ice plant would be advantageous.

### (2) Design and Construction

The lack of basic knowledge in pond engineering among fishfarmers has impaired prawn production. Generally, farmers utilize fishponds designed for milkfish production which are often unsuitable for prawn production. Pond construction in the Philippines is normally carried out without an engineering plan. Prospected areas are merely cleared and enclosed with peripheral dikes. The division dikes, canal system, and gates are laid out according to the farmer's and his workers' convenience. Fishponds usually turn out to have big and irregular compartments with the canal and gate systems improperly located and constructed, and the desired depth never achieved. Even milkfish production fails due to problems brought about by poor design and construction.

The SEAFDEC Aquaculture Department has come up with a design and layout appropriate for semi-intensive culture of prawn (Fig. 3). Salient features of this design include:

- two canal and gate systems, (the drain canal and gate are from the supply canal and supply gate).

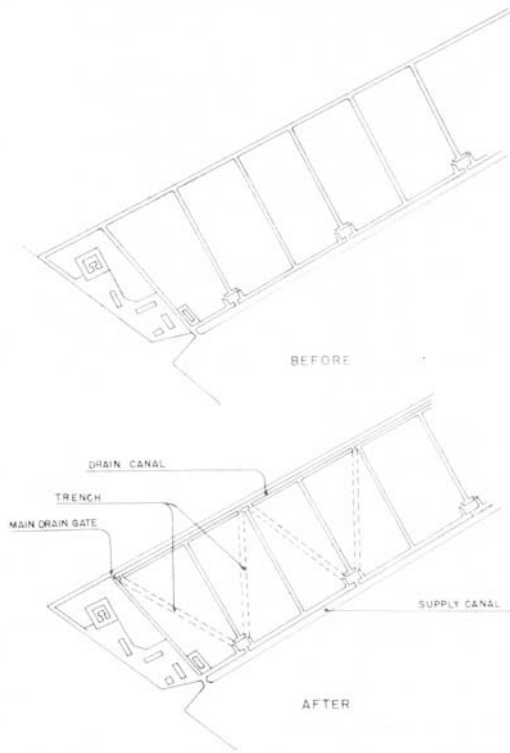

**Fig. 3. Milkfish ponds renovated into prawn semi-intensive culture ponds at LRS SEAFDEC AQD. (After Torres 1983)**

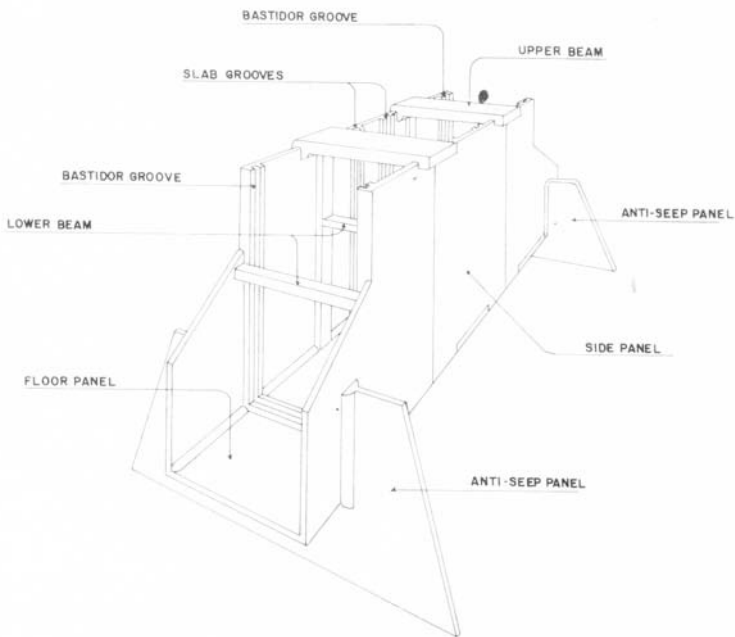

**Fig. 4. Ferrocement sluice gate at LRS SEAFDEC AQD. (After Torres 1983)**

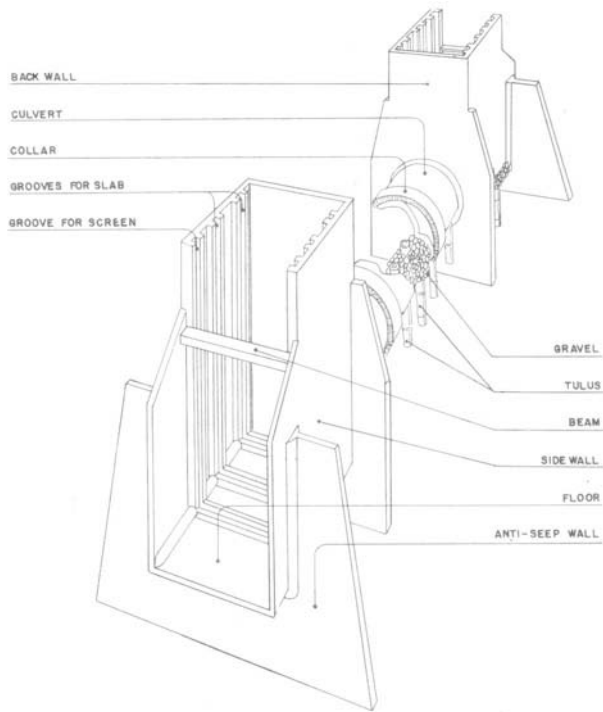

**Fig. S. Ferrocement culvert gate at LRS SEAFDEC AQD. (After Torres 1983)**

Various gate systems have been developed to suit the requirements of pond systems. The monk type culvert and open sluice gates made of ferrocement materials were introduced (Fig. 4 and 5). These gates are cheaper and more convenient to construct and install. They are normally pre-fabricated at a desired mold before transport to the site and installation. They are effective as tertiary and secondary gates. The use of PVC pipes or elbow standpipe gate systems has been also introduced and is effective in smaller ponds such as nursery ponds (Fig. 6).

In extensive culture method where ponds are dependent on tidal fluctuation and where prawns subsist mainly on natural food propagated by fertilization, it is appropriate to develop a progressive method of culture where stock can be transferred from one pond to another when they grow to a certain size. The layout of the ponds can be so arranged as to enable a series of transfers from nursery to transition to growout pond. The ponds should be adjacent to each other to facilitate transfer. Pond sizes should be progressively increased by 1:2:4 ratio to provide a bigger space for the growing prawns. This idea emanated from various research results at SEAFDEC Leganes Research Station where growth rates of *P. monodon* were observed to level off after two months of culture in the same pond. This observation has been confirmed by private operators especially those with stocks dependent on natural food.

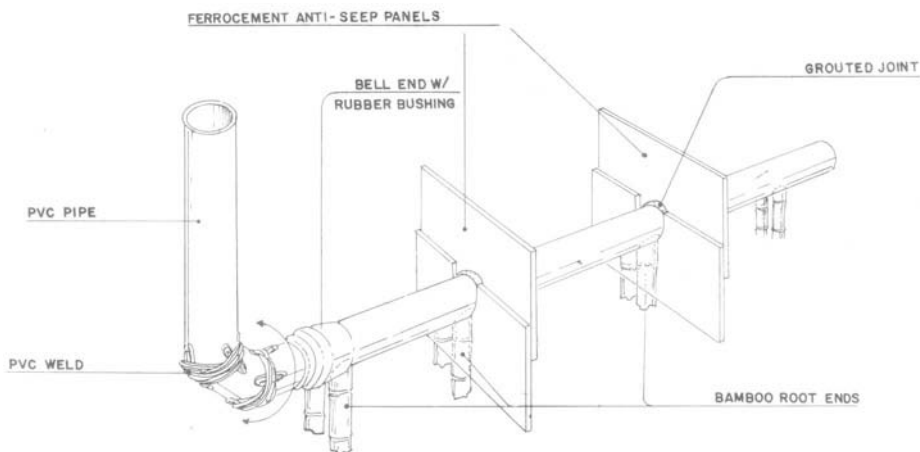

**Fig. 6. PVC stand pipe at LRS SEAFDEC AQD. (After Torres 1983)**

(3) Seed Supply

Seed supply, handling, storage and transport problems have also affected the development of the industry. Seed coming from the wild initially dominated supply for pond culture. The fry are either allowed to enter the pond during high tide or are collected from fry grounds along the shores and estuaries. Since the occurrence of wild fry is seasonal and the quantity is unreliable, cropping becomes irregular and unpredictable. In addition, identifying and separating the mixed collection of penaeid fry also discourage both collectors and farmers. This problem is aggravated by heavy mortalities, as high as 90%, encountered during handling, storage and transport due to lack of skill and technical knowhow.

The development of hatchery techniques gave an alternative and more reliable source of seed supply for pond culture. Despite uncertainties and failures encountered by hatchery operators and fishfarmers during the first few years, more and more hatcheries have been established and more fishfarmers have shifted to hatchery bred fry. The development of improved techniques in handling and transport of fry at SEAFDEC Aquaculture Department has considerably reduced mortalities.

(4) Pest and Predator Control

The entry of unwanted species is a common problem in pond culture. The damage wrought by pests and predators varies widely depend-

ing on the species present in the pond. *Lates calcarifer* (bulgan), *Megalops cyprinoides* (buan-buan), *Elops hawaiiensis* (bid-bid) are among the most harmful predators in ponds. Other pests and predators include tilapia, gobies, snails, small crabs, water snakes and birds. The modular pond method for milkfish culture has minimized this problem to some extent due to frequent transfer and cleaning of ponds (Abesamis 1980, pers. comm.).

Traditionally, pests and predators are eliminated during pond preparation by the use of inorganic pesticides or insecticides. Since most of these compounds are non-biodegradable, they are known to have a cumulative harmful effect to the pond and to the stock itself. Because of this, researchers have warned fishpond operators of the indiscriminate use of pesticides. Organic pesticides such as tobacco waste and derris root may be utilized instead.

Tobacco dust or waste at 280480 kg/ha or commercial nicotine at 12-15 kg/ha was found effective in eliminating snails (Primavera and Apud 1977). This material also keeps the soil soft and moist. Derris root or tubli, *Derris elliptica*, *D. heptaphylls*, and *D. philippinensis* can also be applied at 5-10 ppm in its dried powdered form or as juice extract from 2040 kg raw material per ha. Juice is extracted by pounding and soaking the plant overnight in water and then squeezing it to release the juice.

The bleaching compound sodium hypochlorite (under different brand names like clorox, purex or dulux), at a dose of 20 liters/ha with the water 2 cm deep, can effectively eradicate tilapia and other fin-fishes. Commercial lime mixed with ammonium sulphate is also effective in eliminating almost all kinds of unwanted species in ponds. The recommended ratio of application is 1:5 ammonium sulphate and lime applied at about 500-600 kg/ha. Pests and predators are readily killed as ammonia becomes toxic when water pH is raised by lime to a level above 9. The advantage of these materials is that after a few hours, toxicity subsides and stocking can be done the following day after admitting new tidal water. Lime also reduces acidity, hastens organic decomposition, and eliminates sulfides while ammonium sulphate is a nitrogenous fertilizer. In other countries the use of saponin from teaseed cake applied at the rate of 10-25 ppm (Cook 1976) and commercial rotenone powder extracted from derris root are reportedly effective in eliminating unwanted species. Extra care however is needed if these materials are applied in ponds with prawn stock. Thorough drying of pond during preparation also eliminates pests and predatory fishes.

Entry of unwanted species is prevented by the use of appropriate screen during water management. The traditional practice is to use bamboo screens (locally called *bastidor*) installed at the pond gate. However, this method is not so effective so that other methods have been tried. One of this is the use of window nylon screens on top of the bamboo screen or the *bastidor*. However, this requires continuous brushing during water management as it gets clogged easily. A modifica-

tion introduced at SEAFDEC is the use of the circular netting (*bulon*) in front of the gate or bagnet made of fine mesh nylon screen (0.2 mm) installed in place of the *bastidor* (Fig. 7).

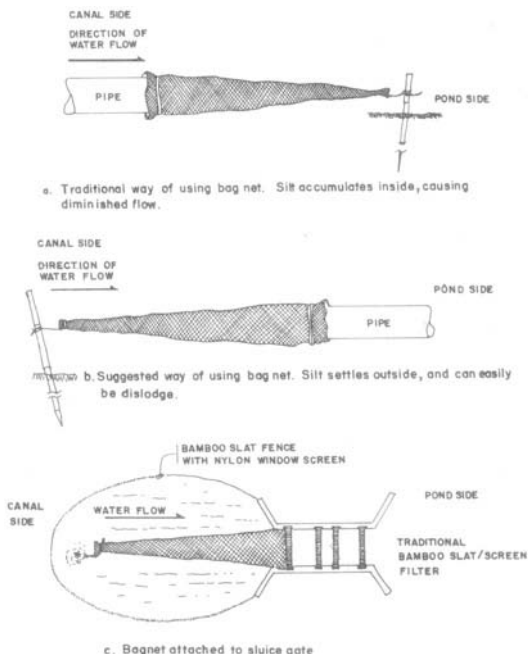

Fig. 7. Different ways of using filter screen and/or bagnet. (After Yap, era/1979)

### Stocking Densities

Stocking densities used by fishfarmers in extensive culture method vary from 2,000-6,000/ha with an average of 4,000 ha both in monoculture or in polyculture with milkfish. When natural food is abundant, about 500-2,000 milkfish is added per hectare. The presence of *sugpo* at the above density levels together with milkfish was found to be favorable for both species. This was confirmed by results obtained from various studies in a polyculture system of milkfish and *sugpo* at Leganes Research Station (Eldani and Primavera 1981; Pudadera 1980; Apud 1981). Eldani and Primavera (1981) pointed out that one of the important benefits of prawn in polyculture with, milkfish is that prawns control the population of chironomid larvae which compete with milkfish for *lablab*. As a result, growth and production of milkfish in ponds with prawns are higher than those without prawns. Gundermann and Pepper (1977) reported the disappearance of chironomous larvae in Fiji ponds several weeks after stocking with *P. monodon*, *P. merguensis* and *P. indicus*.

Stocking densities as high as 10,000-12,000/ha are also practiced by some fishfarmers. These levels require supplementary feeding either during the last two months or last month of culture.



For semi-intensive culture, stocking density may vary from 20,000 to 50,000 individual/ha. These levels were based on the results of various studies on the intensification of prawn grow-out at the SEAFDEC Leganes Research Station (Apud 1978; Destajo 1979; Mo-chizuki 1979; Norfolk *et al* 1980). Apud (1978) observed that survival rates were relatively higher (98.6% and 95.3%) and sizes bigger (23.4 and 18.2 g) in ponds stocked at 25,000 and 50,000/ha as compared with ponds stocked at 100,000 and 200,000/ha (86.4% and 87.6% survival rates and sizes of 11.2 g and 7.3 g, respectively.) The stock was provided with formulated diet in a flow-through system using a water pump within a culture period of 109 days.

#### (6) Food Supply

The natural food propagated in brackishwater fishponds varies from one pond to another depending upon the pond condition and location. In shallow and higher salinity areas (28 ppt and above) *lablab* is dominant over filamentous algae and other higher aquatic plants. In deeper ponds with lower salinity (10-25 ppt) *Chaetomorpha sp* (*lumot jusi*), *Enteromorpha intestinales* (*bitukang-manok*), *Rupia maritima* (*Kusay-kusay*), and *Najas graminea* (*digman*) are dominant. Diatoms, rotifers, nematodes, ostracod, copepods, and other planktonic organisms good for young *sugpo* exist in both environments.

*Lablab* is composed mainly of benthic blue green algae and diatoms. Many forms of animals and other plants are associated with *lablab*. *Lumot*, *kusay-kusay*, and *digman* are also associated with other organisms that contribute to their nutritive value. The yields of certain ponds dominant with *kusay-kusay* and *digman* are found to be relatively higher than in the *lablab* pond. It is believed that these plants and those organisms associated with them give the appropriate nutritional requirement for prawns. In addition to the shelter effect of these aquatic plants, the higher oxygen production, and the lower salinity for which these forms of plants usually exist also contribute to better prawn production.

*Lablab* is a natural food preferred by young *sugpo* (Villaluz 1953), but its excessive growth can be deleterious once the excess begins to decompose. This retards *sugpo* growth usually after the second month of culture.

Marte (1978) identified Crustacea (small crabs and shrimps) and mollusks making up 85% of the ingested food of *P. monodon* caught in the wild (Makato River, Aklan). The remaining 15% consisted of fish, polychaetes, ophiuroids, debris, sand, and silt. She noted that feeding activity was high during ebb tide when tidal current brought in a greater volume of food at estuaries and mouth of rivers.

Although the stock in an extensive culture method is mainly dependent on natural food grown in ponds, some farmers provide various kinds of supplementary feeds every now and then depending upon

their availability. The most common feeds given are rice bran, trash fish, chicken entrails, cattle hide, mussel meat, toads, and snails.

Studies relating to nutrition have been undertaken at SEAFDEC AQD to gather information regarding the nutritional requirements of *P. monodon*. Pond studies using SEAFDEC and commercial diets for semi-intensive culture method include those of Apud 1978; Destajo 1979; Mochizuki 1970; Norfolk 1980; Suemitsu 1981; Tabbu 1982. Despite some encouraging results of these studies the appropriate local commercial feed and feeding techniques are yet to be established. Both researchers and fishfarmers agree that one of the keys to the success of pond culture is food. The economics of feeding should also be looked into. A certain high grade formulated diet with some imported ingredients was found to be efficient with an FCR of 1.5 to 1.7 but costs more than twice that of other commercial products. Research aimed at finding local substitutes with comparable efficiency for less cost must be pursued.

#### (7) Water Management

Water management in the extensive method of prawn farming is an adaptation of that used in milkfish culture. It is totally dependent on tidal fluctuation. During spring tide, water is replenished by draining a portion of the pond water a few hours before the incoming high tide. At high tide, fresh tidal water is admitted. These activities of draining and flooding are done consecutively everyday during the entire spring tide period. Normally, the first 2 to 3 days are devoted to draining and flooding; in the succeeding days, draining is stopped but flooding is continued until water requirement is satisfied (Primavera and Apud 1977).

For semi-intensive culture water management is a combination of both tidal fluctuation and water pump support. During the first two months of culture, the pond water is replenished during spring tides. This is easily achieved in areas with lower elevations. However, pumping is necessary during neap tides particularly in areas with higher elevations to maintain desired water quality and depth. The accumulation of metabolites at the pond bottom lowers water quality. Organic decomposition depletes dissolved oxygen (to levels below 3 ppm) and prawns cease to eat. Feed thrown into the pond under this condition will only add to pollution.

#### (8) Diseases and Parasites

Only a few cases of disease problems in ponds have been reported with the extensive method of culture. Among those observed are the "black gill" disease which may be caused by fungus, bacteria or detritus. Necrosis of appendages, which at earlier stages results in browning of the exoskeleton, pleopods, periopods, telson/uropods, spreads towards the base of appendages and leads to erosion of infected areas. The etio-

logy of this disease in *P. monodon* has not yet been worked out according to Gacutan (1979). However, shell disease of this nature as in other penaeids can be caused by bacteria such as *Chitinoclastic*, *Benechea*, *Vibrio*, and *Pseudomonas* (Cook and Lofton 1973, as cited by Gacutan 1979). Progressive destruction of the exoskeleton provides places for the entry of secondary infections which may cause death.

Body cramp is another problem which can cause high mortality. This is usually encountered during handling, transfer or harvesting on hot days. The body of cramped shrimp curves and becomes rigid. The cause of this is unknown but according to Liao (1977) this can be avoided by handling shrimps during cool days. Fuzzy growth on the exoskeleton is another disease which can be caused by bacteria, protozoans, or algae. The first two are associated with poor water quality due to high organic matter content. Growth is retarded and molting is inhibited by this fuzzy growth.

The most common complaint of fishfarmers is the occurrence of soft-shelling. In this condition prawns are weak and molting is inhibited so that they stop growing. This disease may be attributed to poor nutrition and poor pond condition. Baticados (pers. comm.) attributed soft shelling to different factors such as microbial, environmental, and nutritional deficiency. She also believes this could be caused by trace amounts of insecticides coming from agricultural areas. This belief is supported by observations that soft shelled prawns are common in areas contaminated with runoffs from rice fields using insecticides. Investigation is being undertaken by SEAFDEC researchers to confirm the hypothesized causes.

#### (9) Harvesting

In the extensive culture method, harvest takes place after 4 to 6 months culture in ponds. The prawns may attain 20-60 g depending on the salinity, stocking density, feed and water management.

Harvest may be done through different methods depending on whether a partial or a total harvest is desired. Partial harvest may be done with the use of bamboo traps (*bakikong*), pound nets (for selective partial harvest Fig. 8) or cast nets. With traps or pound nets, it is advisable to partially drain water at daytime and re-admit water in the evening to make the prawns move around. This is most effective during spring tide of the new moon. Prawns can be lured into the traps by placing lights over them in the evening. Cast net operation can be efficiently done by placing feed in certain area to gather the prawns before casting the net.

Total harvest is commonly done with the use of a bagnet (*lumpot*) placed at the sluice gate. Just like *bakikong*, the pond water is partially drained at daytime and new water admitted to get the prawns moving around. In the evening, the bagnet is installed at the discharge portion of the gate after which the gate is opened. The bagnet must be long

enough (8-10m) to make emptying easy. The common practice is to accumulate a big volume in the bagnet before emptying if in big baskets or pails. This lowers the quality of the harvest as the prawns are subjected to too much pressure. A technique of emptying the catch every now and then at limited quantities of about 10 kg to appropriate net bags was introduced recently. The same net bag container is used in washing and immersing the catch in ice water.

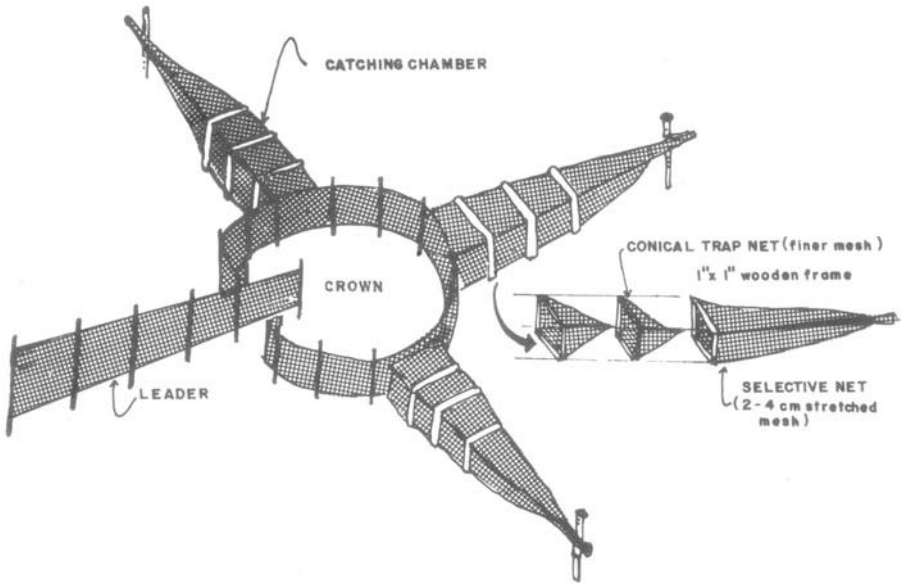

**Fig. 8. The selective harvesting net collects only large animals undersized prawns can return to the pond. (After Suemitsu, 1983 and Apud, *et al.* 1983)**

Another method applicable for total harvest after some partial harvesting is by the gradual draining of the pond to concentrate the prawns in the pond canals or catching pond. Once the prawns are impounded, a drag net is used to collect them. A bamboo screen can be pushed around the peripheral canal to gather the shrimp in a restricted area where they can be caught with a scoop net.

Some farmers build large bamboo traps in the outlet canal outside the drain gate. As the pond is drained and the gate opened, prawns are carried into the canal and down into the traps. Remaining prawns are picked up after all the water has been drained from the pond.

## REFERENCES

- Apud, F.D. 1979. Effects of water movement and aeration system on the survival and growth of hatchery-bred sugpo (*P. monodon*) fry reared in earthen nursery ponds. U.P. Visayas, Iloilo, Phils., M.S. thesis (unpublished).
- \_\_\_\_\_ 1982. Handling and rearing of hatchery produced shrimp postlarvae from small scale hatcheries. FAO/UNDP-SCS, WP/81/SPH/CP 12, 87-93.
- Apud, F.D., J.H. Primavera and P.L. Torres, Jr. 1983. Farming of prawns and shrimps. Aqua. Ext. Manual No. 5 Revised 1983. SEAFDEC Aquaculture Department.
- Apud, F.D., K. Gonzales and N. Deatras. 1981. Survival, growth and production of *Penaeus monodon* Fab. at different stocking densities in the earthen ponds with flow through system and supplemental feeding. Fish. Res. J. Phils. 6:1-9.
- Apud, F.D. and M. Sheik. 1978. Design and construction of prawn nursery pond system. Readings on Pond Management. SEAFDEC Aquaculture Dept.
- Apud, F.D., N. Deatras and K. Gonzales. 1981. Feeding behavior and food preference of *Penaeus monodon* Fab. with scrap *Tilapia mossambica*. Fish. Res. J. Phils. 6:27-31.
- Caces-Borja, P. and S.B. Rasalan. 1968. A review of the culture of sugpo, *Penaeus monodon* Fabricius in the Philippines. Rome FAO, 2:111-123.
- Cook, H.L. 1977. Some aspects of shrimp culture research with particular reference to Philippine species. Fish Res. J. Phils., 2:50-53.
- Delmendo, M.N. and N.R. Rabanal. 1955. Rate of growth of the sugpo (jumbo tiger shrimp) *Penaeus monodon* Fab. with notes on its culture in brackishwater ponds. Proc. 2nd Indo-Pacific Coun., 6:424-431.
- Delmendo, M.N. and H.R. Rabanal. 1956. Cultivation of "Sugpo" (Jumbo Tiger Shrimp), *Penaeus monodon* Fabricius in the Philippines. IPFC Proc. 6th Session Section 1:424-481.
- Eldani, A. and J.H. Primavera. 1981. Effects of different stocking combinations on growth, production and survival of milkfish (*Chanos chanos* Forskal) and prawn (*Penaeus monodon* Fab.) in polyculture in brackishwater ponds. Aquaculture, 417.
- Gabasa, P.G., Jr. 1982. Recent development in design and management of small-scale hatchery for *Penaeus monodon* in the Philippines. FAO/UNDP-SCS, UP/81/SPH/CP 11:77-85.

- Gacutan, R.Q. 1979. Diseases of prawns. Brief: Technical Consultation, SEAFDEC Aquaculture Dept. 13 pp.
- Liao, L.C. 1977. A culture study on grass prawn, *Penaeus monodon* in Taiwan-the pattern, the problems and the prospects. J. Fish. Soc. Taiwan, 5(2): 11.-29.
- Marte, C.L. 1978. The food and feeding habit of *Penaeus monodon* Fab. collected from Makato River, Aklan, Philippines. SEAFDEC Aquaculture Dept., Quarterly Res. Report Vol. 11, No. 1:9-17.
- Mochizuki, H. 1979. The present prawn culture in the Philippines. Terminal Report to Aquaculture Dept., SEAFDEC: 1-60 with 33 figs (mimeo).
- Norfolk, J.R.W. 1981. The use of ammonium sulfate as a pesticide during pond preparation. Asian Aquaculture, 4:7.
- Norfolk, J.R.W., J.N. Paul and D.S. Javellana. 1981. A preliminary report on intensification of prawn grow-out at SEAFDEC Leganes Research Station Perspectives, Problems and Prospects. Unpub. report., 10 pp with 4 figs and 7 tables.
- Platon, P.R. 1979. Present status of prawn farming in the Philippines. Brief: Technical consultation. SEAFDEC Aquaculture Dept. 22 pp.
- Primavera, J.H. 1976. Survival rates of different *P. monodon* postlarval stages reared in hapa nets in brackishwater ponds. Phil. Jour. Sci., 105 (3): 103-109.
- Primavera, J.H. and F.D. Apud. 1977. Manual of Operations: Sugpo pond culture. Extension Manual, SEAFDEC Aquaculture Dept., No. 2, 18 pp.
- Primavera, J.H., F.D. Apud and C. Usigan. 1976. Effects of different stocking densities on survival and growth of sugpo (*Penaeus monodon* Fab.) in a milkfish rearing pond. Phil Jour. Sci., 105 (3): 193-203.
- Pudadera, B., Jr. 1980. Evaluation of milkfish (*Chanos chanos* Fors.) and prawn (*Penaeus monodon* Fab.) in polyculture systems. U.P. Visayas, Iloilo, Phils. M.S. thesis.
- Tang, Y.A. 1961. The use of saponin to control predaceous fishes in shrimp ponds. The Prog. Fish Cult., 23(1): 43-65.
- Torres, P.L., Jr. 1983. Fishpond design and construction. SEAFDEC Aquaculture Dept. 17 pp + 14 figs and 1 table, (mimeo).
- Villadolid, V. and D.K. Villaluz. 1951. The cultivation of sugpo (*Penaeus monodon* Fab.) in the Phils. Phil Fish. J. 1:155-65.
- Villaluz, D.K. 1953. The cultivation of sugpo (*Penaeus monodon* Fab.) Fish Farming in the Philippines, Bookman, Inc., Manila, 137-148.

- Villaluz, D.K., A. Villaluz, B. Ladrera, N. Sheik and A. Gonzaga. 1969. Reproduction, larval development and cultivation of sugpo (*Penaeus monodon* fab.) Phil. Jour. Sci., 98(3 & 4): 205-236.
- Yap, W.G., H. Mochizuki and F.D. Apud. 1978. Mass transport of sugpo *Penaeus monodon* juveniles. Unpub. manuscript.
- Yap, W.G., F.D. Apud and J.H. Primavera. 1979. Manual on prawn farming. Aquaculture Extension Manual, SEAFDEC Aquaculture Dept. No. 5:46 pp.





# STATUS OF PRAWN (*Penaeus monodon*) FEED DEVELOPMENT IN THE PHILIPPINES

Felicitas Piedad-Pascual  
Researcher  
SEAFDEC Aquaculture Department

## INTRODUCTION

Approximately a decade ago the culture of sugpo or tiger prawn (*Penaeus monodon*) was in its infancy. Prawns were stocked alone or together with milkfish and fed mainly on natural food present in the ponds. High market prices, increased consumer demand, and availability of the seeds through artificial propagation in the last six years have brought about a shift towards more intensive culture of prawns. With the advent of monoculture and more intensive farming of sugpo has come a greater demand for an external source of food because natural food organisms in the ponds would no longer suffice to meet the dietary requirements of the prawns.

The intensive culture of prawns requires knowledge of their nutrient requirements in order to provide adequate food for growth and survival. Knowledge of their feeding habits is also important particularly in feed development. Prawn culturists and nutritionists are faced not only with problems of nutritional requirements but also practical considerations such as physical features of the diet, methods and frequency of feeding, feeding behavior and feed preferences at various stages of the life cycle, effects of the food on water quality, amount of feed and types of facilities appropriate for culture.

## NUTRIENT REQUIREMENTS

We have little information on the nutrient requirements of *P. monodon*. There is likewise scarce data on the availability of protein, fats and carbohydrates. Unlike terrestrial animals, there is little information on digestible nutrient, digestible energy, and metabolizable energy for available feed ingredients. Consequently, for practical purposes, prawn feed formulations are computed in the absence of hard data for *P. monodon* using the scanty information and values derived from other species.

Supplementary feeds in the form of chicken entrails, frog meat, mussel meat, trash fish, worms and snails are available but problems related to storage and unpredictable availability of these have led to the search for other feed.

### a. Protein and amino acids

We have been evaluating animal and plant protein sources. Squid meal, shrimp meal, mussel meat, fish meal, shrimp head meal and earthworm meal, have been found to be good animal protein sources (Lim et al 1979; Pascual unpub). Soybean meal and ipil-ipil (*Leucaena*) leaf meal of not more than

10% in the diet can substitute for part of the animal protein source. However, the presence of more than 0.1% mimosine in ipil-ipil leaves limits its use in prawn diets, although soaking the fresh leaves in water for 24 hours and air drying thereafter removes around 85% of the mimosine (Pascual and Penaflores 1979). Similarly, raw soybeans contain an anti-nutrient factor, trypsin inhibitor, which is rendered inactive by heating.

So far, optimum ratio inclusion of fish meal and shrimp head meal is two-thirds of the animal protein from fish meal and one-third from shrimp head meal (Pascual and Destajo 1979).

Alava and Lim (1983) used squid meal, fish meal and shrimp meal, casein and soybean meal as protein sources in diets with protein content ranging from 25 to 60% protein. Their results showed that 40% protein diet gave the best growth rate. However, comparable results were obtained with shrimps fed the 30, 35 and 45% protein diets. In another study by Pascual (manuscript), diets containing 40% protein from shrimp head meal, fish meal, earthworm meal or squid meal, and soybean meal gave survival rates almost twice that of a 32% protein diet that did not have earthworm meal or squid meal. At present, we suggest the use of 40% protein in the diet.

The amino acid pattern of the protein source is an important factor in the choice of protein sources. Furthermore, the amount of protein incorporated in a diet is partly determined by the ratio or balance of amino acids in the protein sources. Amino acids are building blocks for protein synthesis and unless they are available in the proper amounts in the diet, animal growth is retarded. Coloso and Cruz (1980) have shown that arginine, histidine, isoleucine, leucine, lysine, methionine, phenylalanine, threonine, tyrosine and valine and probably tryptophan are essential to *P. monodon*. Other shrimps have been found to need the same amino acids. Coloso *et al* (unpublished data) have determined the amino acid pattern of PL<sub>40</sub> while Catedral and Penaflores (1977) analyzed the amino acid pattern of the muscle of wild *P. monodon*. The amino acid profile in prawn tissue protein can be used as a guide in the search for natural protein sources or a combination of these sources such that an optimal amino acid pattern could be supplied in the diet assuming that all the foodstuffs are digestible. The amino acid requirement of *P. monodon* is not yet known although the literature provides for other species such as *P. japonicus* (Deshimaru 1981).

## b. **Lipid and Fatty Acids**

Lipids are necessary not only for their energy value but also for the presence of fatty acids and fat-soluble vitamins important to the growth and survival of the animals.

The effect of various oils like corn oil, soybean oil, beef tallow, pork lard and fish oil on the growth of *P. monodon* juveniles has been studied (Mangalik 1979). Fish oil is the best, followed by beef tallow, soybean oil, copra oil, corn oil and pork lard, in descending order. In a recent study by Mendoza (1982) the diet containing 11.7% lipid gave maximum growth, efficient feed conversion and protein efficiency ratio, and optimum survival rate.

She also reported that the total body fat increased with increasing levels of dietary lipid.

Fatty acid composition of postlarvae is generally related to the fatty acid pattern of the diets. Total body lipid was found to be higher than that of the pre-experimental animals (Yashiro 1982). The study concluded that cooked mussel meat is a good feed in place of *Artemia* as it is cheap and readily available.

Preliminary data gathered from an on-going study by Millamena (pers. comm.) on the fatty acid profile of the ovaries, hepatopancreas and tail muscle of wild *P. monodon* indicate that there is a predominance of higher long chain polyunsaturated fatty acids of arachidonic acid (20:4 $\omega$ 5), eicosapentaenoic acid (20:5 $\omega$ 3) and docosahexaenoic acid (20:6 $\omega$ 3) in prawn broodstock.

Results from a study by Nalzaró (1982) with a practical formulation indicate that a total cholesterol level of around 1% is required for maximum growth, high feed conversion, high protein efficiency and survival rate and maintenance of constant level of body cholesterol.

#### c. **Carbohydrates**

Carbohydrates in prawn diets are not only useful for their energy value but also for their binding properties. Carbohydrates and fats are known to be protein spacers and provide part, if not most, of the energy needed in the diet. Among the carbohydrates that have been studied are sucrose, dextrin, maltose, glucose, molasses, cassava starch, cornstarch and sago palm starch. Sucrose and sago palm starch 10% in the diet were found to give better survival rates than the other carbohydrates tested at the same level. However, changes in the hepatopancreatic cells were observed (Pascual *et al* 1983).

#### d. **Vitamins and Minerals**

We have not done work on vitamins and minerals. We rely on commercial poultry vitamin-mineral mixes or use those figures published in the literature such as those of Deshimaru (1981).

#### e. **Energy Requirement**

There are indications that prawn juveniles need between 3,100 to 3,300 kcal/kg of diet but this has not been confirmed (Bautista unpub.).

## **DIET DEVELOPMENT**

Aside from nutritional requirements, practical problems related to the physical features of the diet have to be solved. Water stability, attractability, size, shape, density and texture are some of these considerations.

The prawn is a slow eater and nibbles its food so that a water stable pellet is necessary. A 34 hour stability is preferred. Use of a finely ground feedstuff and a good binder gives water stable pellets. We have tried a number of binders: sweet

potato starch, cassava starch, extract of shark fins, *Gracilaria*, gum arabic, alginate, glutinous rice, carboxymethyl cellulose, carrageenan, corn starch (Pascual *et al* 1978; Pascual and Tabbu 1979; Murai *et al* 1981; Pascual and Sumalangcay in press), and sago palm starch (Lim and Destajo 1979). Sweet potato starch causes pellets to mold easily and has poor binding capacity. Other binders are either too expensive or not commercially available. We have found sago palm starch, cornstarch and alpha potato starch as acceptable for laboratory use at 5% level in the diet. Alginate and carboxymethyl cellulose are good but expensive binders. Carrageenan is a potential binder. Another procedure essential for making a water stable pellet is gelatinization of the starch before the addition of dry ingredients. Steaming the pellet during or after extrusion adds to stability.

Attractiveness of the diet to the prawn is also necessary. Several attractants have been tested by incorporating shrimp, mussel, squid, fish extract, mussel extract in purified diets (Pascual 1980). Murai *et al* (in press) used krill meal, earthworm meal, glycine, sucrose and mussel water as attractants in a practical diet. Addition of krill meal, earthworm meal and sucrose improved attractability to a certain extent. Glycine supplement and mussel significantly improved attractability. Furthermore, dietary groups supplemented with any type of attractant showed better average weight gain than those fed the diet without attractant. Prawns fed the diet with earthworm meal had the best growth rate. Best feed conversion was also achieved with the diet containing earthworm (Murai *et al* in press). Perhaps diet attractability, *per se*, may be a vital factor in determining the quality of compounded feed for prawn, and that earthworm meal as an attractant in prawn diets significantly improves growth, survival and feed efficiency of *P. monodon* juveniles.

## FOOD AND FEEDING HABITS

Much information on dietary requirements can be extracted from food intake studies in the natural habitat. Marte (1980) reported that around 85% of the ingested food of *P. monodon* caught from the wild in Makato, Aklan consisted of crustaceans (small crabs and shrimps) and molluscs. The remaining 15% was composed of fish, polychaetes, ophiuroids, debris, sand and silt. Furthermore, about 95% of food is transported from the foregut four hours after feeding. Results showed that *P. monodon* feeds on slow moving benthic organisms. Crustaceans appear to be the "staple" food while molluscs contributed the largest bulk; the undigestible shell fragments may have been retained longer in the gut. Wild prawns from Makato showed significant monthly variations in the feeding activity.

## DIET FORMULATIONS

There is one formulation that we have continued to improve as we get more information on the nutritional requirements. There are several commercial companies that are producing feeds while a few fishfarmers prefer to prepare their own feeds. All ingredients or feedstuffs should be finely ground (around 425 microns) and homogenous. The starch is first gelatinized before adding to the dry previously

mixed ingredients when feed is prepared under laboratory conditions. Unlike fish diets, prawn diets have to be conditioned with steam. All of these procedures are necessary for the production of compact, water stable pellets.

A formulation has been published and used as the basis for some of the commercial feeds in the market. It stands to be improved. Some fishfarmers have consulted us with regards to the diet formulation and have made their own feeds using our extension manual (1983) as a guide in feed preparation. The local commercial companies that manufacture prawn feeds, to my knowledge, are Robina, Vitarich, San Miguel, First Farmers and Techno Dynamics.

Four diets have been tried in ponds twice and results show that feeding does increase survival and provide for better growth (Tabbu *et al* unpublished) than without feeding. However, feed conversion ratios (FCR) were inconsistent in two runs. Our SEAFDEC formulation had an FCR of 1.8 in the first run and 6.1 in the second run. Although commercial feeds are now available and supplemental feeding has been found necessary in semi-intensive and intensive cultures there is no one ideal formula. All of these rations do provide for "better" growth and survival although we have not been able to determine a good growth rate. Feed is only one of the factors for increasing growth and survival rates. Proper water management and the use of healthy animals are just as necessary.

Cost of feedstuffs has escalated as with other items in the market. However, one would have to do his own feasibility study as to whether it is cheaper to make one's own feed or to buy them. Supplementary feeding is needed when stocking density is more than 1-2/sq m and the choice of feed as to whether it is moist or pelletized will also depend on the availability of fresh trash fish, chicken entrails, frog meat, etc, and proper storage facilities. There is more thiaminase, an enzyme that destroys the vitamin, thiamine and other nutrients are also destroyed in deteriorated fish. One advantage of dry pelletized over moist or wet feed is that its quality can be controlled. Furthermore, storage space with refrigeration is needed for keeping wet diets from deteriorating fast. Likewise, dry pelletized feed should also be stored properly to prevent the growth of fungi that produce toxins.

## LARVAL DIETS

Artificial feeds for larvae remains a puzzle. Natural food like phytoplankton and zooplankton - *Tetraselmis*, *Chaetoceros*, *Skeletonema*, *Brachionus* and *Artemia* - seem to be the choice although egg yolk, finely ground squid and mussel are now being used in prawn hatcheries. There are flaked as well as micro-encapsulated diets being tested in some laboratories here and abroad (Kanazawa *et al* 1982). One of the problems with artificial larval feeds is the need to always have feed in the water column but not to the extent of polluting the water. Thus a feed that can remain in the water for a certain period with minimal leaching out of nutrients has to be developed.

## BROODSTOCK DIETS

Knowledge of the characteristics of a good broodstock diet is scanty. Results

from the study of Marte (1982) indicate that there are certain nutrients in molluscs and fish which are required for gonad development because during the appearance of spawners, these feeds are found abundantly in the gut of the prawns.

Molluscs occur in the gut more frequently than crustaceans in August, December, March, April and June while fish remains appear in more prawns in August, January, and March. According to Motoh (pers. comm.) preliminary data indicate that peak season of *P. monodon* spawners in the same area occur around April, August and November. This suggests that prawns feed on food like molluscs and fish which they would need for gonad development (Marte 1982). The study of Millamena *et al* (in progress), as previously stated, showed higher polyunsaturated fatty acids in tissues of wild prawn broodstock which are also present in molluscs and fish liver oils. Primavera *et al* (1979) fed broodstock with mussel meat alone or in combination with pellets and got higher survival and better reproductive performance from those fed mussel meat alone or in a combination with pellets than those that were not offered any mussel meat.

## THE FUTURE

Many questions remain unresolved. Are we feeding the prawns or are we feeding the pond? What are the changes that occur in the food before it is eaten by the prawn? How much of the nutrients are lost? How sure are we that the feed is really available to the prawns? How do stocking density, oxygen concentration, temperature and salinity and exposure to disease relate to the quality and quantity of the feed being tested?

The researcher is often faced with the problem of quality control in feedstuffs. The lack of standardized quality local ingredients makes it difficult for the researcher to duplicate his study, and the need to analyze every batch of feed ingredients used in the study adds to the cost of research and development. Many of the locally available feedstuffs are not of high quality so that duplication of the same feed and of experimental results is difficult to obtain. One often resorts to the use of imported feedstuffs for reasons based on quality. However, due to lack of proper storage of imported feedstuffs, the researcher is also faced with the problem of poor quality by the time the feed reaches the laboratory. The presence of pesticide residues in some of the local feeds like rice bran or tikitiki has also to be resolved because this can cause mass mortality. Some pesticides used in plants and taken in by insects have been found to prevent chitin formation, one possible reason for soft shelling in prawns.

Perhaps some kind of legislation or assistance from the industry and fishfarmers' organizations is needed to hasten the solution of these problems..

We do not know the requirements for minerals and vitamins, specific fatty acids and amino acids. Larval feeds and broodstock diets have yet to be developed. Diets developed for grow-out in the laboratory have to be tried under various pond conditions, and this takes time. When fishpond owners agree to cooperate, certain inputs are necessary and should be met before or during the experimental runs, otherwise interpretation of data collected becomes very difficult.

The problems are tremendous but a collective and well directed effort may eventually lead to the solution of many of these problems.

## LITERATURE CITED

- Alava, V.R. and C. Lim. 1983. The quantitative dietary protein requirement of *Penaeus monodon* juveniles in a controlled environment. *Aquaculture*. 30 pp. 53-61.
- Catedral, F. and V. Peñaflores. 1977. Amino acid analysis of *P. monodon* muscle. SEAFDEC AQD Quart. Res. Rep. 4th Qtr. (Oct.-Dec.) Vol. I No. 4 p. 1.
- Coloso, R.M. and L.J. Cruz. 1980. Preliminary studies in some aspects of amino acid biosynthesis in juveniles of *Penaeus monodon* Fabricius Bull. Phil. Biochem. Soc. 3(1&2): 12-22.
- Deshimaru, O. 1981. Studies on nutrition and diet for prawns, *Penaeus japonicus*. Memoirs of Kagoshima Prefecture Fisheries Exptl. Station, No. 12. p. 7.
- Kanazawa, A.S. Teshima, H. Sasada and S. Abdel Rahman. 1982. Culture of the prawn larvae with micro-particulate diets. Bull. Jap. Soc. Fish. 48 (2): 195-199.
- Lim, C. and W.H. Destajo. 1979. Effects of crude semi-purified and purified starch of sago (*Metroxylon sagu Rotto*) on the water stability of pelleted shrimp diets. Fish. Res. J. Phil. Vol. IV No. 1 pp. 19-23.
- Lim, C., Suraniranat P. and Platon R.R. 1979. Evaluation of various protein sources for *P. monodon* postlarvae. *Kalikasan Phil. S. of Biology*. 8: 29-36.
- Mangalik, Arthur. 1979. Effects of various lipid sources on the growth and survival rates of *Penaeus monodon* Fabricius from postlarvae to juveniles in a controlled environment. M.S. Thesis. College of Fisheries Univ. of the Phil. 65 pp.
- Marte, C.L. 1980. The food and feeding habit of *Penaeus monodon* collected from Makato River, Aklan, Philippines. *Crustaceana*. 38 (3): 225-236.
- Marte, C.L. 1982. Seasonal variation in food and feeding of *Penaeus monodon* Fabricius (*Decapoda natantia*) *Crustaceana*. 42 (3) p. 250-255.
- Mendoza, E.C. 1982. Quantitative dietary lipid requirement of *P. monodon* juveniles in a controlled environment. M.S. Thesis. College of Fisheries, Univ. of the Phil, in the Visayas. 33 pp.
- Murai, T., A. Sumalangcay and F.P. Pascual. 1981. The water stability of shrimp diets with various polysaccharides as binding agents. Quart. Res. Rep. April-June, 1981. Vol. V, No. 2 pp. 18-22. SEAFDEC AQD Tigbauan, Phil.
- Murai, T., A. Sumalangcay and F.P. Pascual. Supplement of various attractants to a practical diet for juvenile *Penaeus monodon* Fabricius. In press.

- Nalzaró, G.G. 1982. Quantitative dietary cholesterol requirement of *Penaeus monodon* juveniles. M.S. Thesis College of Fisheries, Univ. of the Phil. in the Visayas. 47 pp.
- Pascual, F.P. 1980. Attractants in purified diets. SEAFDEC AQD Quart. Res. Rept. 2nd Quart. (April-June) Vol. IV, No. 1 p. 7.
- Pascual, F.P. 1983. Nutrition and feeding of *Penaeus monodon*. Extension Manual No. 2, 3rd ed. p. 5.
- Pascual, F.P., L. Bandonil and W.H. Destajo. 1978. The effect of different binders on the water stability of feeds for prawn. Quart. Res. Rep. 1st Quart. Jan.-Mar. Vol. pp. 31-35.
- Pascual, F.P., R. Coloso and C. Tamse. 1983. Survival and some histological changes in *P. monodon* Fabricius juveniles fed various carbohydrates. Aquaculture. 31 pp. 169-180.
- Pascual, F.P. and W. Destajo. 1979. Growth and survival of *Penaeus monodon* post-larvae fed shrimp head meal and fish meal as primary animal sources of protein. Fish Res. Journal of the Phil. Vol. IV No. 1. p. 29.
- Pascual, F.P. and V. Penaflores. 1979. The extraction of mimosine from ipil-ipil leaves (*Leuceana leucocephala*) by soaking in water. Quart. Res. Rept. 3rd Quart. (July-Sept.) Vol. III. p. 4.
- Pascual, F.P. and Sumalangcay, A. Jr. Gum arabic, carrageenan of various types and sago palm starch as binders in prawn diets. In press.
- Pascual, F.P. and M. Tabbu. 1979. Fishwater and agar as binders in a prawn diet. Quart. Res. Rept. 1st Quart. (Jan.-Mar.) Vol. 3 No. 1 p. 1.
- Primavera, J.H., C. Lim, C. and E. Borlongan. 1979. Feeding regimes in relation to reproduction and survival of ablated *Penaeus monodon* Fab. Kalikasan. Philipp. J. Biol. 8: 227-235.
- Yashiro, R.H. 1982. The effects of *Artemia* fed with different diets on the growth and survival of *Penaeus monodon* Fabricius postlarvae. M.S. Thesis. College of Fisheries, Univ. of the Phil, in the Visayas.



# THE PROCESSING AND EXPORTING OF PRAWNS IN THE PHILIPPINES

George Tan  
AA Export-Import Corporation

## INTRODUCTION

In this paper, processing and marketing of prawns in the Philippines, I shall refer solely to black tiger prawns, popularly known as *sugpo* or *lucon* and scientifically known as *Penaeus monodon*.

The Philippines abounds in rich tropical fishing waters, both coastal and offshore. The area has been greatly increased by the 200-mile economic zone and the archipelagic law. Prawns are caught in these waters and the catches are both for domestic consumption and export. In addition, prawns specifically the black tiger variety, have been produced from aquaculture for many years. We have large tracts of culture farms and many more are being developed each year. Total export production in 1983 was estimated at 4,450 MT, 2,000 MT from Philippine waters and 2,450 MT from culture farms all over the country. These were exported mainly to Japan and the United States in processed and quick-frozen form.

## PROCESSING

Processing starts with proper handling of the prawns caught from the seas or harvested from fishponds as they are transported to the processing plants. Usually, the newly caught or harvested prawns are temporarily refrigerated by packing them with crushed ice in insulated containers. These containers are transported from the fishpond by trucks or fishing vessel to the processing plant where processing is carried out in the following stages:

1. Washing in clean cold water
2. Classifying according to buyer's requirements and specifications either as:
  - A. Whole - the prawn is left with head and shell intact;
  - B. Headless - head is removed with shell intact, or
  - C. Peeled - the head and shell are removed
  - D. Peeled - head, shell and veins are removed
3. Sizing according to internationally accepted sizes ranging from under 8 pieces per pound to 90 pieces per pound;
4. Weighing the sized prawns according to buyer's requirement;
5. Rinsing again with clean cold water before positioning the sized prawns in tin containers;
6. Filling up the tin containers with clean fresh water;

7. Quick-freezing the processed prawns in the water-filled containers;
8. Removing the frozen blocks from the containers and wrapping the blocks successively in plastic bags, consumer packs and bulk packs;
9. Cold storing the fully wrapped prawns at low temperature ready for export.

To process one metric ton a day, a work force of about 30 persons is required. Significantly, all nine stages are completed without the aid of foreign manpower. Except for the imported freezing equipment, the technology is available locally.

Each stage of the processing can be mechanized. However, the machines have to be custom-built and are rather costly. For example, a shrimp peeling machine from Australia would cost at least US\$50,000.

A workable alternative is to mechanize the quick-freezing process and manually perform the other processes. As quality is essential, extreme care must be taken to ensure that the hands of the workers are clean at all times during the processing. Also, due to the perishable nature of the product, it is advisable to import efficient and durable quick-freezing equipment to ensure continuous operation and avoid huge losses due to machine breakdown. It is also important to maintain optimal operational efficiency of the equipment by hiring competent technical personnel.

Experience has shown that it does not pay to scrimp on capital expense by using substandard equipment. As freezing does not kill the bacteria but simply stops or slows down their growth, the faster the processed prawns are quick-frozen by the right equipment, the higher their quality. A shorter freezing time preserves the freshness of the prawns better. And it saves energy.

What happens if the exported prawns are found to be contaminated as a result of negligence during processing because of dirty hands, unsanitary conditions, poor equipment or some other causes? The consequence is damaging. The US, Western Europe and Australia will return the shipment with all extra expenses charged to the exporter. Japan will burn the entire shipment if the Japan Quarantine Department, which is very sensitive to cholera and other contamination, finds a contaminated block from a random sampling of the shipment. While the exporter may be covered by insurance against loss from rejection, his business will inevitably suffer. Either he is going to be charged with costlier insurance premiums or he loses his insurers, buyers, brand name, not to mention the bad reputation he has given to the Philippines. It takes only one contaminated shipment to condemn a brand name and the country of origin of the shipment.

## **EXPORTING**

Although proper processing of prawn is essential to successful operations, the more difficult aspect is marketing or exporting the product. This involves not only quality as in processing but also pricing, delivery, promotion and competition.

## **PRICING**

The pricing of prawns as with other products depends to a large extent on supply and demand. But just like other exports, pricing is critically affected by

other factors such as foreign exchange rates of trading countries, which for us is the US\$, Japanese yen and Phil. peso; labor and packaging costs; freight; taxes; and government policies and incentives.

In a recent statement, former BOI Minister Vicente Paterno commented that price control on agricultural products is a negative factor in the national effort to increase production and income. He said that "the best incentive to farmers and investors to venture into desired areas of production is to give them a favorable price for their efforts." We strongly agree with this observation and feel that the present 6% export tax for prawn, 1% producers tax and 1/2% Bureau of Fisheries Inspection Fee serve as disincentives to higher production.

## **DELIVERY**

Delivery of exported prawns has to be consistent and in quantities worthwhile to the importer. This will encourage importing countries to view the Philippines as a reliable source of continuous supply thereby putting us in a more favorable bargaining position for better export prices.

## **PROMOTION**

Constant promotion of the product and brand name is essential to creating a strong demand for the product and commanding a premium price for the brand name. For example, BT prawns were not popular in Japan before our company (AA Export & Import Corp.) pioneered in its export with an initial shipment of 400 kg in 1975. Today, the export of Philippine BT prawns is over 2,000 MT a year. This marketing success story is primarily attributable to the extensive information campaign through cooking demonstrations, brochures and other advertising and promotional activities conducted to educate the Japanese consumer. The consumers were made to realize that although our BT looks greenish black and unappealing when raw, it turns beautifully bright red when cooked. Not only does BT look good when cooked, it is excellent in taste and most suitable for popular Japanese dishes like tempura.

Attractive packaging helps a lot in increasing saleability and establishing a brand name. Once the product has been established as being of superior quality, the brand name becomes the guarantee of that quality. Once a brand name is accepted, it is important to improve and maintain its image. Various advertising and promotional programs have to be launched and sustained to increase sales. This requires mutual cooperation between the exporter or owner of the brand and the importer and its marketing outlets.

## **COMPETITION**

The major market for Philippine prawns is Japan, followed by the US. Competition for these markets is keen among countries in the Asia-Pacific region as well as some countries in Central and South America.

## 1. The Japanese Market

Japan's importation of frozen shrimps and prawns was 161,000 MT in 1981, 151,397 MT in 1982 and dipped below 150,000 MT in 1983.

BT prawns have become widely accepted in the Japanese market. It recently edged out the white shrimp variety as the most expensive prawn in Japan. Japan imports its BT prawns primarily from Taiwan, Philippines, Indonesia and India. While Indonesia and the Philippines traditionally commanded a higher price for its BT prawns, Taiwan has been able to sell its BT prawns at a better price lately. Some Japanese consumers claim that Taiwan's BT prawns taste better due to the quality feeds used in Taiwanese fishponds as opposed to the natural food used locally. If this is true, it behooves the Philippines to keep abreast with the latest aquaculture technology not just to increase volume but to improve the taste as well. In this connection, it is significant to note the pioneering efforts of San Miguel Corporation in this field.

How does the Philippines compare with other countries that are exporting shrimps and prawns to the Japanese market?

The Philippines exports monthly about 300-550 MT, 80% of which goes to Japan. While some may consider this plentiful, it accounts for only about 2% of the Japanese market.

Compared to other Asian countries, our total exports of shrimps and prawns to Japan ranked us among the top ten suppliers for the first time in 1982 with a total volume of 3,694 MT (valued at US\$37,521,000).

India and Indonesia have continuously occupied the top two positions both in the quantity and value of their exports, which together accounted for about 42% by quantity and 38% by value of Japanese importation of shrimps in 1982. Thailand has climbed to 4th while Taiwan to 5th in 1982. They expect to maintain if not improve their ranking. Others like China, Pakistan and even Bangladesh are continually trying to improve exports to Japan with strong government support. The Philippines cannot afford to simply watch or we will lose out to our very aggressive Asian neighbors in the Japanese market.

## 2. The US Market

The US market for prawns is big, being largely supplied by Mexico, Brazil and other Latin American countries. Only a few Philippine companies are shipping to the US partly because of relatively lower prices than that offered by the Japanese market and partly because of strict FDA regulations applied to Philippine shrimps as a result of previously contaminated exports. Ayala started to sell to the US two years ago, followed by SUGECO of Cebu. Their successful operations have helped boost the Philippine's prawn exporting image.

Recently, the prices of BT prawns in the US have become compe-

titive with Japan. Taiwan has moved in and is now engaged in a vast promotion campaign for its products. More Philippine exporters should penetrate the US market to capture a bigger share of the market for the country.

### 3. Other Markets

Besides Japan and the US other markets like the Middle East and Europe should likewise be tapped. Again, exporters should carefully study the buyer's needs and requirements as to variety, sizes, packaging, and price.

## CONCLUSION

There is, no doubt, a big potential for increased exports of our shrimps and prawns can be realized because of the:

1. strong demand for our product,
2. large tracts of natural fishponds and lands suitable for aquaculture development,
3. geographical proximity to Japan, the largest importer of BT prawns, which provides comparative advantage in freight costs.

The main concern of the prawn industry and government should be how to convert this tremendous potential into increased production and therefore more foreign exchange earnings for the country. Needless to say, increased exports would help alleviate the present economic difficulties the country is experiencing. However, we should not allow ourselves to think that the industry is already that big contrary to the rosy picture that mass media reports portray.

The prawn export industry is still in its infancy and it needs strong government support to be more price competitive in the world market. Hence, the recent imposition of the 6% export tax for shrimps and prawns is a hindrance to the industry's growth. While, the government needs revenues, it should not be at the expense of increased exports. None of the other major producing countries tax their shrimp exporters. On the contrary, governments like India, Taiwan and Indonesia provide tax incentives and soft loans to encourage producers to produce more and exporters to export more. Our government should do no less.

Finally, both government and private sector should actively engage in aquaculture research and development to ensure greater productivity through more efficient BT hatching and culturing techniques.

We have gone a long way in the last eight years of exporting BT. We can do much more. With strong government support and encouragement, we can work harder and more effectively to increase productivity at the fishponds, improve quality at the processing plants, cultivate better business relationship with our existing customers, and promote our products vigorously in existing as well as new markets.



# GOVERNMENT POLICIES ON AQUACULTURE

**Jesus D. Valerio**  
**Ministry of Natural Resources**

## INTRODUCTION

For the coming years, existing policies on aquaculture need not be drastically altered. Such move would be an affront to the wisdom and maturity of the political leadership that conceived them. As it is, the wellspring of this wisdom is impeccable: the basic longings of the Filipino people as expressed in our constitution and legal codes, as well as that which all mankind accept as fundamental tenets of equity.

However, altruistic policies are arrows that should end up precisely at their target. A policy passes through a series of transmutations: it must be interpreted by bureaucrats, refined by technocrats, and implemented by an organization or institution.

Thus, national policies are first translated into specific laws which in turn the Ministry of Natural Resources transforms into rules and regulations and then into operating procedures by the Bureau of Fisheries and Aquatic Resources, the Fishery Industry Development Council and the Philippine Fishery Development Authority. This circuitous path may lead to results not totally in agreement with the original intention of the policy.

To avert what may go wrong, an evaluation of the institution and men who allocate resources to carry out a policy is in order. By identifying their strengths and weaknesses, we may arrive at the right course towards the fulfillment of policy goals.

First, it is essential to assess the capability of an institution for policy study, formulation, and implementation so that we may understand better why policies succeed or fail. While policy formulation is a built-in item in the activities of all government ministries, it is often underplayed due to lack of funds and competent personnel. As a result, those given the titular job of policy planners must content themselves with inadequate, or at worst, hearsay data and information, in order to form semblances of policy studies.

A case in point is the dearth of production data on tiger prawn and other species. National statistics on brackishwater production does not qualify volume by species, making it difficult to ascertain actual performance of this commodity on a macro-level. Similarly, information on fry production both from the wild and hatcheries, as well as the number and distribution of production areas in the country is incomplete.

Hence, for policy studies to be based on rigid, qualitative analysis, and therefore be reliable, government must invest capital to get the right kind of data with the right precision and at the right time. It could entail great expenses in the case of studies on aquaculture.

To be sure, the MNR, would like to aspire for the acquisition of the logistics for real, authentic policy studies. This may be construed as an admission that the Ministry would like, but cannot at the moment, generate models as sophisticated as those turned out by institutions in affluent countries.

## **ECOSYSTEM MANAGEMENT**

The Ministry believes that a more prudent approach is ecosystem management which seeks a balance between immediate gains and long-range benefits in the exploitation of our natural resources. A key MNR policy is the promotion of ecological stability through conservation. But conservation should not be interpreted as keeping and preserving things from using them. Rather, conservation is viewed by the Ministry as "an investment process in which some things are preserved for future consumption - neither good nor bad in itself, but must be evaluated by the resulting shift in the time streams of benefits and costs."

This approach opposes the proposition that maximum production is the only criterion of economic growth. Neither does it undervalue the role of technology but equates the soundness and viability of a technology with the effectiveness with which it can satisfy human needs. Lives Mumford gave a famous definition for this. A viable technology, he said, is one "which provides the right quality at the right time in the right place and in the right order for the right purpose."

Thus, a vital fishery development project which benefits countless number of people should not be abandoned just because it intrudes into the habitat of some rare fish species. Nor should absolute zero effluence be required of industrial plants, knowing that the waterways near them can safely tolerate certain levels of pollution.

As it is, the ecosystem management approach is already operative in the program thrusts of the Ministry. These thrusts subscribe to the following considerations:

*First, that deliberate care should accompany the imposition of human technologies in natural systems. It does not de-emphasize the role of technology as a precursor of economic growth; but it equates the soundness and viability of a technology with the effectiveness with which it can satisfy human needs.*

*Second, human intervention in nature's processes cannot be avoided, but the risks from such intervention can be minimized. This consideration sustains the Ministry's contention that proper management of our natural resources depends on intelligent decisions formulated through conscientious choice of alternatives.*

The social costs in the exploitation of our fishery resources are often neglected by policy makers. These costs are most inequitable when passed on to and paid for by the poor.



In the same vein, one predilection is to base policy solely on economic feasibility in total disregard of ecological impacts which could have serious consequences on the long-term sustainability of the resource. An example of this was the old practice of converting mangrove swamps into commercial fishponds.

The apparent rationale of the policy that allowed it was the acceleration of food production through aquaculture. As a result, during the last ten years or so, our virgin mangrove swamps have been drastically reduced from 400,000 hectares to about only 150,000 hectares today. This was mainly due to the conversion of mangrove areas into fishponds, and in some cases, saltbeds and housing subdivisions.

The mangrove area is breeding ground for many species of fish including shrimps and prawns. Thus, the conversion of mangrove swamps into fishponds could increase fish production in the short-term but could trigger the collapse of nearshore fisheries and cause the decline of the overall fish harvest. The MNR, it must be said, takes cognizance of the mangrove dilemma. Through P.D. 950, the Ministry requires every fishpond lessee to replant or reforest at least a 20-meter strip from the edge of a river bank.

The President, through a directive, pushed for the acceleration of aquaculture development by converting a large percentage of existing fishponds into prawn ponds. Similarly another Presidential Directive issued in 1983 is the establishment of more prawn hatcheries to meet local fry requirements. The directive set a target of P1 B for the next five years.

From this directive the Ministry of Natural Resources initiated the formulation of the Aquaculture Industry Development Program which will chart the general policy directions, targets and strategies for the industry.

However, it has come to our attention that prawn hatcheries are operating at only 50% capacity. Hence, the Integrated Fisheries Development Plan which is now being reviewed aims to promote the operationalization of existing hatcheries to full capacity.

To conserve local stock of spawners which are vital to hatchery operations the government has issued Fisheries Administrative Order (FAO) 143 which calls for the total ban on the export of all live stages of tiger prawn. However, reports of its violation continue to be received by the MNR. It should be noted that other prawn species, particularly at the fry stage, very closely resemble *P. monodon*, providing a venue for exporters to continue illegal trading operations by passing off *P. monodon* as other prawn species not covered by the ban. Prawn species such as *P. indicus* and *P. merguensis* which are gaining wide popularity as alternate culture species have to be protected to avert a possible scarcity.

The policy on the protection and conservation of our shrimps and prawns can be made more viable if additional safeguards are incorporated into the implementation mechanism. However, this would include the provision of more personnel and funds for the enforcement of the ban.

It is also the policy of the Ministry of Natural Resources to improve the country's foreign exchange position through export expansion. As an instrument of this policy, FAO 117 was promulgated. It stipulates the rules and regulations governing the operation of processing plants for fish and fishery and aquatic products, and prescribing as well as requiring standards, quality control and inspection of pro-

cessed fish and fishery and aquatic products. Similarly, rules and regulations governing the issuance of permits for the exportation of fish and fishery and aquatic products has been issued through FAO No. 147.

Fishery statistics reveal that Japan ranks as the major importer of Philippine shrimps and prawns accounting for over 95 per cent of our total export volume. Far behind is the United States (1.8%), Guam and Singapore (4%). This shows that while Japan provides a ready outlet for local prawns, the trade situation has virtually become a "buyers market" with Japan controlling pricing decisions. Hence, the AIDP is considering promoting the industry in Western Europe and the USA.

In order to promote integrated, socially-oriented prawn development programs, Executive Order 609 reduces the tariff duty on imported prawn feeds from 50% to 5%, the lowest *ad valorem* rates imposed on essential consumer items and inputs. Likewise, P.D. 1159, or the Agricultural Investment Incentives Act as amended by P.D. 1789, authorizes additional incentives for agricultural and fisheries activities.

Here then are some policy statements and instruments that may guide the shrimp and prawn industry. Some good spin-offs will likely result from them, but again, it must be emphasized that a policy is only as good as its implementation.

## CREDIT AND FINANCING

### *Loan Exposure*

Among the major credit institutions that have been actively providing credit to aquaculture projects are the Development Bank of the Philippines (DBP) through its regular lending program and the World Bank-financed IBRD Credit Lines, the Central Bank (CB) and the Philippine National Bank (PNB). Aside from their regular lending programs, DBP, CB and PNB are involved in the Biyayang Dagat Supervised Credit Program. Since the late 1940s, DBP has been extending aquaculture credit supporting such projects as salt and fingerling production, mussel and seaweed culture, as well as fishpond development, improvement and operation. To date, P80.5 million has been granted to aquaculture projects under its regular program. Under the DBP-IBRD Credit Lines, an aggregate amount of P173.9 million was released to inland fisheries under the first two Credit Lines. The present Third Credit Line has, thus far released P159 million to the sector.

The Central Bank, on the other hand, has released a total of P183 million financing fishpond and fishpen projects under its four IBRD Credit Lines. It has also channelled around P47 million to fishpond projects under its supervised credit program. The CB is likewise involved in the Biyayang Dagat Program for which it has released P12 million to finance fishponds and other aquaculture activities.

The Philippine National Bank also finances aquaculture projects under its regular lending program where it has invested P92 million and the Biyayang Dagat through which P95,000 has so far been channelled to fund fishpond projects. The Land Bank, on one hand, has granted a total of P11.7

million to fishpond projects and oyster farming. The Aquaculture Credit Administration (ACA) was involved in aquaculture credit until 1975 when the program was suspended. A total of F3.3 million was released for municipal and inland fisheries.

A recent development in aquaculture credit is the active participation of foreign funding institutions such as the Asian Development Bank (ADB) and the International Finance Corporation (IFC). ADB specifically, is providing \$40 million to raise brackishwater fishpond production in selected regions of the country. This will entail provision of credit to operators for pond renovation/rehabilitation and operating expenditures to associations and private sector entities for construction of refrigerated fish carrier vessels. Establishment of fingerling banks and hatcheries are likewise covered by the loan. The project, which will be implemented over a six-year period has been set to be operationalized by this year, 1984. The IFC or the International Finance Corporation, a financing arm of the World Bank, is currently evaluating potential investment areas in Philippine aquaculture. Identified areas of major interest are prawn culture in fishponds and prawn hatcheries.

In terms of loan exposure by type of aquaculture project, fishpond construction and development received the highest share of financing. For DBP, this sub-sector accounted for 92% of total amount released compared to only 5% and 2% for bangus fingerling production and salt making. This situation is similarly reflected in the loan records of other credit channels where the fishpond sub-sector acquired the largest funding share.

There are no long-term lending programs specific to prawn farming. DBP solely finances the development/construction of project area regardless of the type of operation or the culture activity to be undertaken.

The Biyayang Dagat, until 1982, provided short-term financing for aquaculture projects specifically fishponds, fish cages, mussel and oyster farming. This was, however, temporarily suspended when the Program realigned its priorities and concentrated its credit assistance on small-scale capture fisheries. In contrast to other lending programs, Biyayang Dagat only provides production loans, i.e., for the purchase of fry, fertilizers, feeds, etc. Loan ceilings of P5,750 per hectare and P6,250.00 per hectare for bangus monoculture and bangus-sugpo polyculture respectively, were set by the program. Coverage of the loan, however, was for fishfarms not more than 10 hectares in size. A total of F9.7 million was released for fishpond projects benefiting some 577 borrowers throughout the country. On-going aquaculture projects are cage farming which has provided over P2 million to 512 borrowers throughout the country. On-going aquaculture projects are cage farming which has provided over F2 million to 512 borrowers, and oyster and mussel farming which have financed a total of 28 projects amounting to roughly P161,680.00.

A similar lending scheme that aims to upgrade the economic status of small fishermen and fishfarmers in the Kilusang Kabuhayan at Kaunlaran (KKK), a nationwide rural development program that provides financing to cottage and agricultural based industries. Covered under the Aquamarine component are fish culture, sea farming and fish capture. Fish culture in-

cludes the cultivation of *Tilapia* in floating fish cages in underutilized rivers, lakes, reservoirs, bays, or coves, and the polyculture of bangus, prawns and other species in brackishwater ponds along mangrove areas. Seafarming activities that could be financed are oyster and mussel culture as well as seaweed farming.

As of March 1983, *Tilapia* cage/communal hatcheries accounted for the biggest share (36%) in KKK credit for aquaculture. This is followed by mussel/oyster culture (28%), fishponds (23%) and fishpens (4%), respectively. Cognizant of the importance of seed production to sectoral expansion, KKK is actively involved in financing prawn and *Tilapia* hatcheries as well as milkfish nurseries. There is, likewise, a diversity of aquaculture activities, e.g., *Caulerpa*, carp, snail culture, being funded by KKK, consequently encouraging a more active participation of local entrepreneurs.

### ***Incentives and Subsidies for the Prawn Industry***

Agricultural and fisheries activities are two particular fields which the government backs up with the extension of additional incentives. The rationale behind this is their greater susceptibility to investment risks than any other business venture, such as the threats of weather and other environmental hazards.

Under PD 1159 otherwise known as the Agricultural Investments Incentives Act, the proposed fishery activities include:

- (1) Fish and Marine Products - covers all legitimate methods of catching fish in marine waters including processing of fish or marine products, provided it is integrated with fish-capture operations.
- (2) Aquaculture - refers to culturing of all culturable aquatic species in freshwater, brackishwater or marine waters.

Registration under PD 1159 offers more incentives and benefits to fisheries and agricultural enterprises than that under Investment Incentives Act of the Export Incentives Act. These incentives include: Accelerated depreciation of breeding stock; Additional production from taxable income of 25% of research and development expenses and 25% management training expenses of Philippine nationals, provided deduction shall not exceed 10% of taxable income within 7 years from date of registrations; Tax exemption on breeding stocks, fish plants and genetic materials imported within 7 years from date of registration; additional deduction from taxable income of 30% of freight and transportation expenses within 7 years from date of registration of enterprises established in a preferred geographical area for fishery/agricultural development where transport facilities are deficient and such freight and transportation expenses are incurred in the course of transporting registered products from the enterprises' project area to the nearest economic marketing center as determined by BOI.

The following are qualified to register under PD 1159:

- (a) Individuals, partnerships and domestic corporations whose out-

standing voting capital stock is 60% owned by Philippine nationals, cooperatives, and other entities organized and existing under Philippine laws.

- (b) Existing BOI-registered enterprises, NACIDA-registered firms, and cooperatives registered under PD 175, the last two being subject to BOI approval.
- (c) All domestic corporations and partnerships required under General Order No. 47 to undertake corporate farming.
- (d) Registered fishery and agricultural enterprises, individuals and non-fishery and non-agricultural enterprises are qualified to invest in other registered fishery/agricultural enterprises exempting them from the 15% of capital-investment limitation prescribed under the Corporation Law when such investments are made in other registered fishery/agricultural enterprises.

Additionally, the tariff duty imposed on imported prawn feeds was reduced from 50% to 5% per Executive Order No. 609 issued on August 30, 1980. The 5% duty is considered the lowest *ad valorem* rates imposed on essential consumer items and inputs. Although several local companies have ventured into the formulation and marketing of feed preparation (e.g. Vitarich Corporation, Robina Farms, SMC), feeds imported from Taiwan, Hongkong and the United States are still being utilized by local farmers who claim that these are more efficient and in the long run, more economical. The reduced duty also covers the importation of brine shrimp eggs (*Artemia salina*), a live feed integral to prawn hatchery operations.

Aquaculture equipment used for chemical and physical analysis, are charged 10% *ad valorem* rate of duty, the lowest imposed on finished equipment or machinery. Covered by the Tariff and Customs Code of 1978, these instruments such as refractometer, spectrometer, etc. are regularly imported from Japan and the United States.

The lifting of the 4% export duty on exported shrimps and prawns as implemented by Customs Tariff Circular No. 21-79 can be considered a significant assistance to the industry. This move is expected to make the prices of Philippine shrimp more competitive in the international market.

## DBP LOAN RELEASES BY TYPE OF PROJECTS, 1983

Fisheries Credit I		P119,736,400
Marine	49,656,700	
Inland	70,079,700	
Fisheries Credit II		176,223,400
Marine	62,395,700	
Inland	113,827,700	
Third Livestock Fisheries		181,306,200
Fishponds	159,298,600	
Deep-Sea	18,857,800	
Salt Bed	760,700	
Ice Plant	1,529,100	
Lambaklad	360,000	
Shipway	500,000	
<u>DBP Regular Financing Program</u> <sup>1/</sup>		310,419,031
Fishpond/salt bed	71,630,943.04	
Foreshore	184,703,494.03	
Seaweeds (Eucheuma culture)	45,183,389.47	
Other marine (mussel/oyster)	8,807,459.09	
Supervised Credit Program		2,760,200
Biyayang Dagat Program		
Medium term (Fish capture)	2,760,200.00	
	TOTAL	P790,445.231

<sup>1/</sup>1980 data

**LOAN EXPOSURES OF PNB, LB AND ACA \* BY  
TYPE OF FISHERY PROJECTS**

PNB			
	Fishponds	P	92,277,000.00
	Deep sea fishing		85,266,000.00
	Pearl fishing, etc.		11,622,000.00
	Supervised credit program		
	Biyayang Dagat		6,783,749.00
	Medium-term (fish capture)	6,688,749.00	
	Short-term (fishpond)	95,000.00	
		TOTAL	<u>195,948,749.00</u>
LB			
	Fishponds		11,615,118.70
	Oyster farming		<u>60,532.00</u>
		TOTAL	<u>11,675,650.70</u>
ACA			
	Municipal/inland		<u>3,305,404.41</u>
		TOTAL	<u>P 3,305,404.41</u>

\*PNB — Philippine National Bank  
 LB — Land Bank  
 ACA — Agricultural Credit Administration

**CENTRAL BANK LOAN RELEASES FOR FISHERIES  
BY TYPE OF PROJECT  
June 1981**

	Marine (Deep-Sea)	Aquaculture (Fishpond/Fishpens)	Total (P)
CB-IBRD CREDIT LINES			
CB-IBRD I <sup>1/</sup>	—	—	—
CB-IBRD II	1,844,478.78	7,287,416.05	9,131,894.83
CB-IBRD III	4,163,000.00	13,281,000.00	17,444,000.00
CB-IBRD IV	15,848,000.00	162,757,000.00	178,605,000.00
			<hr/> 205,180,894.83
SUPERVISED CREDIT PROGRAM			
CB-DRBSLA Under the IAF-PVTA (Fishpond)			12,413,689.00
CB-DRBSLA Under the IAF-NEDA (Fishpond)			31,325,710.00
CB-DRBSLA-SFSCF Fund-NFAC (Fishpond)			2,919,813.00
SFSCF DAP-FIRM (Fishing boat)			650,000.00
Biyayang Dagat Program			90,357,108.00
Medium-term (fish capture)	78,217,232.00		
Short-term (fishponds)	10,459,016.00		
Other (Aquaculture Activities)	1,680,860.00		
			<hr/> 137,666,320.50
		TOTAL	<hr/> 342,847,215.33

<sup>1/</sup> A total of P1.3 million was released under this credit line for poultry, livestock and fish culture.



**KKK LOAN RELEASES BY TYPE OF FISHERY PROJECT,  
March 1983**

I. AQUACULTURE		
Sugpo/Tilapia culture		40,000.00
Tilapia cage/fish cage/communal hatcheries		9,287,538.15
Fishpen (bangus)		981,094.60
Snail culture		100,000.00
Carp/tilapia culture		533,761.00
Mussel/oyster culture		7,154,812.00
Fishponds		5,903,861.08
Bangus fingerling production		18,000.00
Communal backyard fishpond		726,966.00
Seaweed culture		529,886.00
Lato (Caulerpa) culture		146,808.00
Shrimp culture		32,097.50
Prawn hatchery		100,000.00
	TOTAL	P25,554,824.33
II. CAPTURE		
Fishing gear		90,628,462.35
Seashell diving		79,000.00
Sea cucumber gathering		35,000.00
Bangus fry gathering		876,841.00
Net construction		10,000.00
Crab fry gathering		241,897.08
Boat making		798,430.00
	TOTAL	P92,669,630.43
III. PROCESSING/MARKETING (141,153,505.85)		
Fish processing		16,778,548.09
Bagoong making		774,818.00
Salt making		245,707.00
Ice plant/cold storage		905,950.00
Marketing		4,224,028.00
	TOTAL	P22,929,051.09

## **Additional Incentives to Agricultural Producers under PD No. 1789**

All registered enterprises engaged in agricultural production and related services, whether pioneer or non-pioneer shall be granted the following incentives in addition to those provided for registered enterprises.

<i>Incentive</i>	<i>Terms and Conditions of Availment</i>
1) Tax duty exemption on breeding stocks and genetic materials	<ul style="list-style-type: none"><li>• Within seven years from date of registration.</li></ul>
2) Deduction of research and development programs and management training expenses	<ul style="list-style-type: none"><li>• Should not exceed 25% of the research and development expenses and 25% of the management training expenses of Philippine nationals.</li><li>• Deduction on both programs should not exceed 10% of taxable income.</li><li>• Within a period of seven years from date of registration of the enterprise.</li></ul>
3) Deduction of freight and transportation expenses	<ul style="list-style-type: none"><li>• Should not exceed 30% of freight and transportation expenses.</li><li>• Within a period of five years from date of registration of commercial operation.</li><li>• Projects must be located in a preferred area for agricultural development and where transport facilities are deficient.</li></ul>





**AQUACULTURE DEPARTMENT**  
**SOUTHEAST ASIAN FISHERIES DEVELOPMENT CENTER**  
Tigbauan, Iloilo, Philippines