



Aquaculture Extension Manual No. 1
Revised July 1978

**Design, operation and economics
of a small-scale hatchery for the larval rearing
of sugpo, *Penaeus monodon* Fab.**

Rolando R. Platon



AQUACULTURE DEPARTMENT
SOUTHEAST ASIAN FISHERIES DEVELOPMENT CENTER
Tigbauan, Iloilo, Philippines

**Design, operation and economics
of a small-scale hatchery for the larval rearing
of sugpo, *Penaeus monodon* Fab.**

Aquaculture Extension Manual No. 1

Revised July 1978



AQUACULTURE DEPARTMENT
SOUTHEAST ASIAN FISHERIES DEVELOPMENT CENTER
Tigbauan, Iloilo, Philippines

Table of Contents

I	Introduction	1
II	Biology of <i>Penaeus monodon</i>	1
III	Site selection criteria for a hatchery	2
IV	Physical facilities required for a hatchery	5
V	Culture of natural feeds	9
VI	Disinfection of spawners	17
VII	Spawning and hatching	17
VIII	Rearing in larval culture tank	18
IX	Harvesting technique	19
X	Pre-treatment and transport	19
XI	Economics of small-scale hatchery	19

Design, operation and economics of a small-scale hatchery for the larval rearing of sugpo, *Penaeus monodon* Fab.

Rolando R. Platon

I. Introduction

The economic importance of *Penaeus monodon* Fabricius (sugpo, prawn) cannot be overemphasized. This is evidenced by the interest shown by aquaculturists in Southeast Asia in the mass culture of this species. One of the major problems in the mass production of sugpo is how to obtain a constant supply of fry. Since ultimately it is the private sector which should produce the sugpo fry to fill the needs of the industry, the Barangay Hatchery Project under the Prawn Program of the Aquaculture Department of SEAFDEC has scaled down the hatchery technology from large tanks to a level which can be adopted by the private sector, especially in the villages, with a minimum of financial and technical inputs.

This guide to small-scale hatchery operations is expected to generate more enthusiasm among fish farmers interested in venturing into sugpo culture.

II. Biology of *Penaeus monodon*

Wild, gravid *P. monodon* females spawn in the open sea. It takes about 2 weeks from hatching of the eggs through the planktonic larval stages until the postlarva. Benthic postlarvae are found along the coast or in mangrove swamps and other estuarine areas where they are collected by fry gatherers for rearing in brackishwater ponds up to marketable size of 16 to 30 pieces per kilogram. Wild fry become juveniles and adults in estuarine areas but return to the sea for spawning.

The degree of ovarian maturation in a sugpo female is determined by holding the spawner against a bright light and checking the outline of the ovaries located in the back of the prawn (Fig. 2). The five stages of development are Stage I (immature/undeveloped) — ovaries thin, translucent and hardly visible; Stage II (early maturing/developing) — ovaries yellow, increasing in size and visible through the exoskeleton with the anterior and middle lobes starting to develop; Stage III (late maturing/nearly ripe) — ovaries green, middle and anterior lobes fully developed; Stage IV (mature/ripe) ovaries dark green with the prawn ready to spawn; Stage V (spent) — ovaries similar to those of Stage I and II.

A spawner weighs from 90 to 200 grams, producing on the average 500,000 eggs per spawning. The maximum number of eggs recorded from one female is more than 1,000,000.

After spawning, it takes about 12 to 15 hr before *P. monodon* eggs hatch to the nauplius stage. There are six naupliar substages, labeled for short as N₁ to N₆. From N₁, a nauplius molts 5 times to N₆ within 48 to 56 hr. Nauplii at substage N₆ molt to the zoea stage. The zoea stage has three substages, Z₁, Z₂, and Z₃, all of which are completed within 5 to 6 days. The next and last larval stage is the mysis. This also has 3 substages (M₁, M₂, and M₃), which are completed in 4 to 5 days. The postlarva stage follows. P₄ to P₆ is the normal substage at which postlarvae are harvested for stocking in ponds. A subscript identifying a postlarva approximates the number of days from the start of the postlarval stage. The life cycle of *P. monodon* is shown in Fig. 1.

Postlarvae stocked in brackishwater ponds attain harvest size in 4 to 7 months.

Because of the severe conditions in the open sea, aquaculturists estimate that the survival rate from egg to postlarva is only a fraction of 1%.

A hatchery is an artificial environment which increases the survival rate for larval development — from the egg to nauplius, zoea, mysis and, finally, postlarva — using scientific techniques for feeding and environmental management.

III. Site selection criteria for a hatchery

Careful evaluation of various criteria should be conducted before deciding on the site of a hatchery. The principal criteria are the following:

1. Seawater quality and quantity. Seawater with minimum seasonal fluctuation in quality is most desirable. It should not be affected by inland discharges containing agricultural runoff or industrial wastes. Turbidity should be as low as possible. Adequate volume of seawater should be available when needed. The best method to determine the suitability of sea water for larval rearing is to conduct preliminary larval rearing experiments using pails or small tanks on the site. The production of postlarvae with reasonable survival rate from eggs in a series of at least three runs would indicate the likelihood of success in actual operations.

2. Source of spawners. Whether the spawners to be used in the hatchery are matured by means of eyestalk ablation in tanks, cages or pens, or caught from the wild, it is most desirable for a hatchery site to be near the source of spawners for a constant supply. Although there are existing techniques of transporting spawners over long distances, the quality of eggs may be greatly affected by the transport stress.

3. Road accessibility. The hatchery should be accessible by road for convenience in transporting supplies and other necessities for the hatchery operations. This can also minimize transport problems in the distribution of the postlarvae to be reared in ponds far from the hatchery.

4. Availability of electric power. Electrical power is necessary for the life support system in the hatchery. Although an independent generating unit is desirable as a standby, it is cumbersome for the hatchery staff to operate on a continuous basis.

5. Fresh water source. The need for fresh water is minimal but an adequate supply is essential for miscellaneous activities and personal needs of hatchery staff.

6. Availability of technical staff. The technical expertise necessary for hatchery management at this stage is still rare. More incentives should be provided for technical staff recruitment.

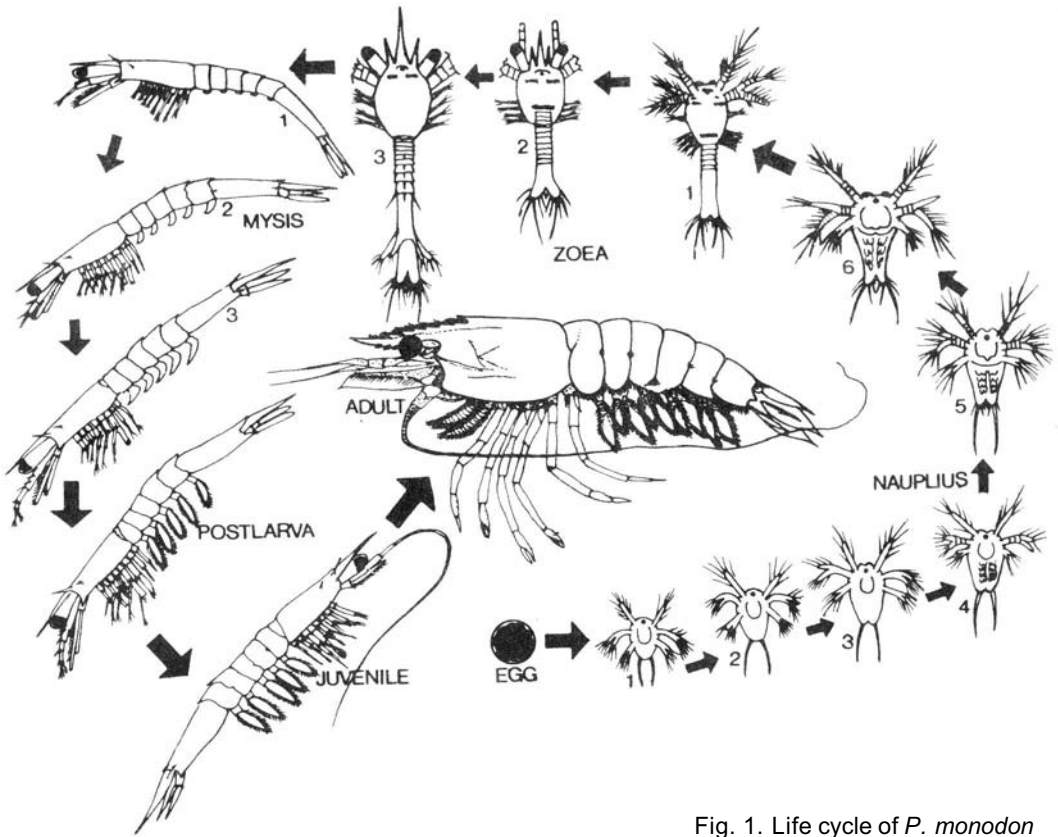

Fig. 1. Life cycle of *P. monodon*

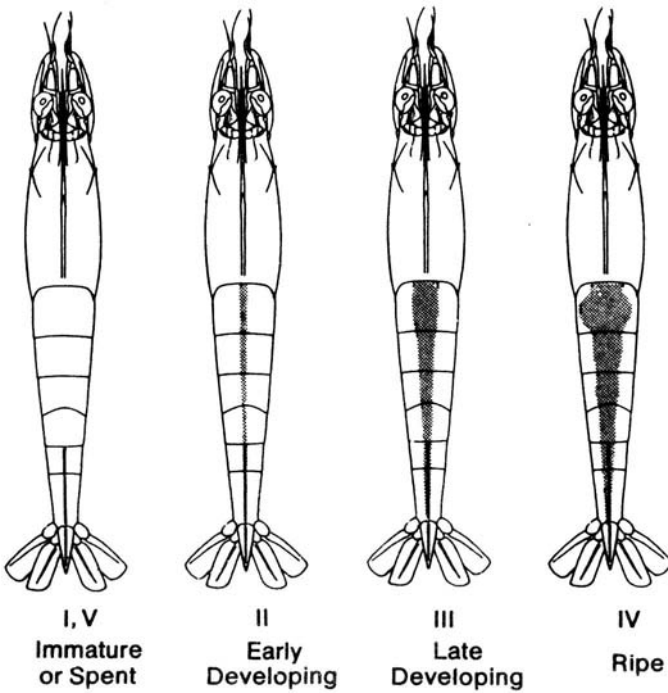

Fig. 2. The appearance of the ovarian mass at the different stages of maturity.

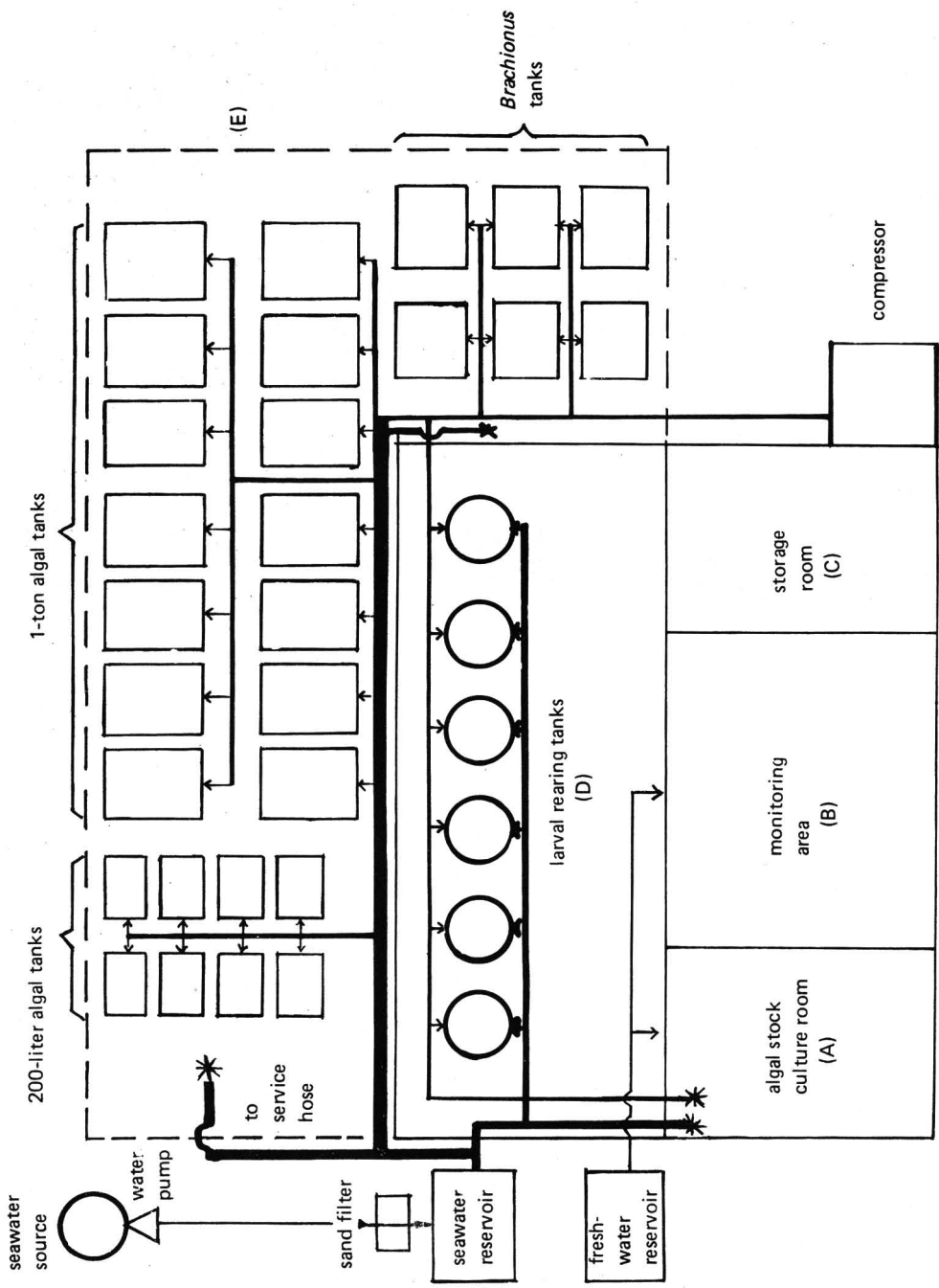

Fig. 3. Layout of a small-scale hatchery system.

IV. Physical facilities required for a hatchery

1. Seawater supply system. A good seawater source has a salinity range of 28 to 32 ppt and is free from pollution. The water intake may either be from an inshore well or right in the sea, but it is necessary to filter from the seawater larger organisms such as fish and jellyfish, as well as silt and mud during heavy runoff. This is done by employing a sand filter. The pipes are preferably made of PVC and should be fully exposed for easier maintenance (Fig. 3).

Table 1. Seawater and pump requirements for different hatchery capacities.

Hatchery capacity	Maximum total consumption (L/day)	Recommended reservoir volume (L)	Total water consumption per run (including 15% of actual for washing), (L)	Theoretical pump hp requirement with 6 m head (kW)	Recommended pump hp (kW)
1 tank	3,000	1,500	36,900	0.025 (0.018)	0.1 (0.0746)
5 tanks	12,000	6,000	149,000	0.075 (0.056)	0.3 (0.224)
10 tanks	25,000	12,500	296,000	0.150 (0.112)	0.6 (0.448)
15 tanks	37,000	18,500	433,000	0.200 (0.149)	0.8 (0.597)

2. Air supply system. Aeration can be provided by a compressor or blower capable of delivering air at an effective pressure of 1.5 meters column of water. In addition to providing the oxygen requirement to the culture water, the air supply also induces circulation and agitation to enable the cultured organisms to remain suspended at a uniform distribution. PVC pipes are also preferred for air distribution lines.

3. Larval culture tanks. A 2-ton larval rearing tank may be made of marine plywood shaped into a cylinder with octagonal cross-section and conical bottom (Fig. 5). Epoxy paint is recommended for the inside coating. Aeration in these tanks is by means of airstones attached to plastic tubings. The volume of air is controlled by air cocks firmly attached to the air supply line.

4. Algal rearing tanks. Wooden tanks 60 cm deep and of 1-ton capacity are used for algal culture. These tanks are provided with aeration for efficient circulation and suspension of the culture. Shallow tanks like these are recommended to allow light penetration through the culture medium (Fig. 7).

5. *Brachionus* culture tanks. One-ton cubic wooden tanks provided with proper aeration can serve as culture containers for *Brachionus* (Fig. 8).

6. Building. A roofed structure with walls is necessary to house the larval rearing tanks, the algal starters, and a monitoring area (Table 4).

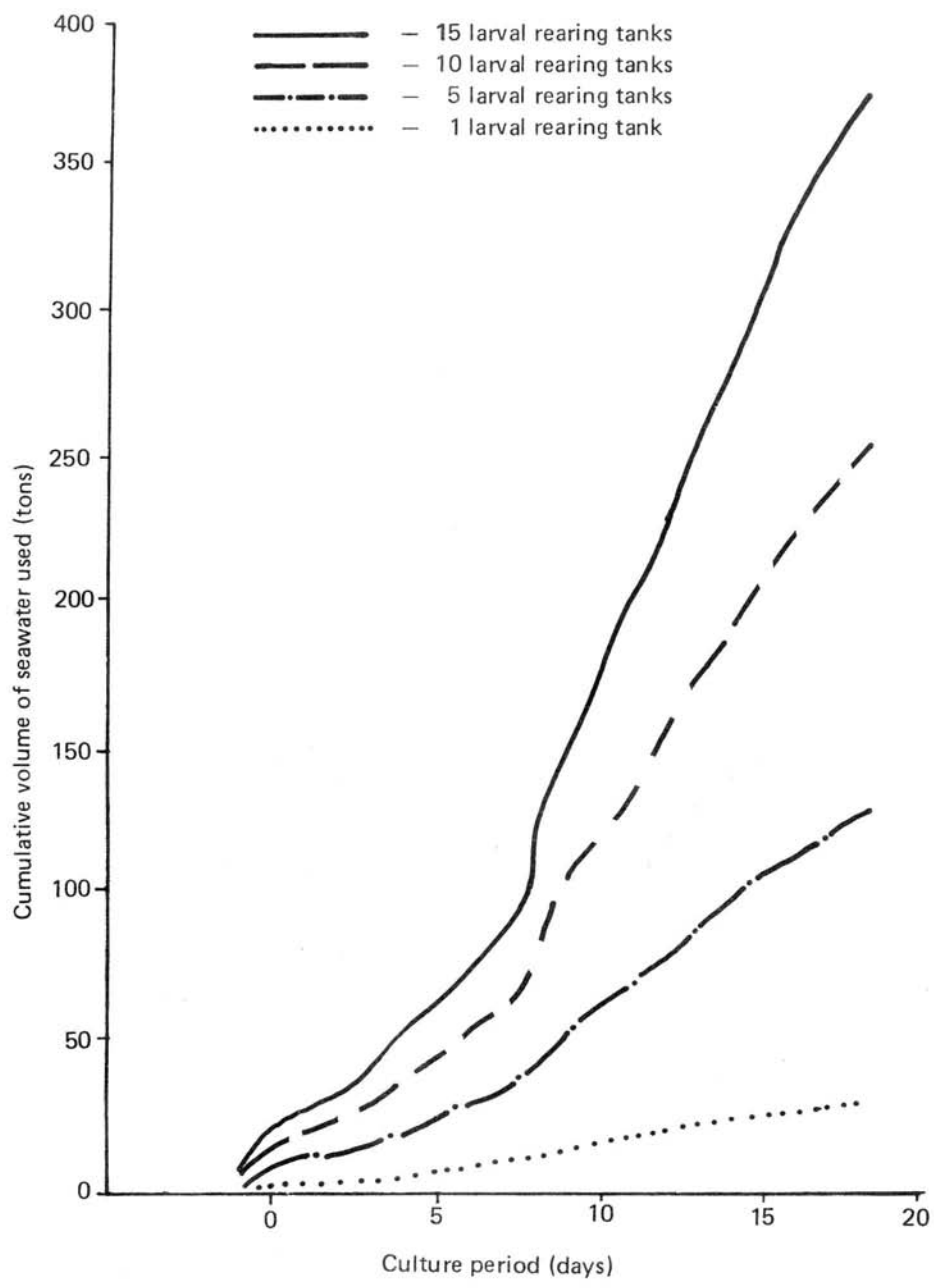

Fig. 4. Cumulative water consumption for different hatchery capacities.

Table 2. Compressed air requirements for different hatchery capacities.

Hatchery capacity	Theoretical hp requirement (kW)	Recommended actual hp (kW) at 0.2 kg/cm ²	Total air volumetric requirement, (L/min)
1 tank	0.16 (0.12)	0.64 (0.48)	430
5 tanks	0.305 (0.228)	1.22 (0.91)	820
10 tanks	0.533 (0.398)	2.13 (1.59)	1430
15 tanks	0.71 (0.53)	2.84 (2.12)	1910

Table 3. Algal and *Brachionus* tank requirements for different hatchery capacities.

Hatchery capacity	<i>Chaetoceros</i> culture tanks (1-ton)	<i>Tetraselmis</i> culture tanks (1-ton)	<i>Brachionus</i> culture tanks (1-ton)	<i>Chlorella</i> culture tanks (1-ton)	200-L algal tanks
1 tank	3	-	1	2	5
5 tanks	6	3	3	2	5
10 tanks	9	6	6	2	7
15 tanks	12	6	8	3	7

Table 4. Area requirements of a hatchery installation for different capacities, in square meters.

Hatchery capacity	A	B	C	D	E	F	Total
1 tank	6	8	4	10	45	7	80
5 tanks	6	12	6	30	60	16	130
10 tanks	9	12	9	50	90	23	193
15 tanks	9	12	12	70	120	25	248

- A = Algal culture room, inside building
- B = Monitoring area, inside building
- C = Storage compartment, inside building
- D = Larval rearing area, inside building
- E = Outdoor algal and *Brachionus* production area
- F = Combined area for compressor, reservoir, and sand filter

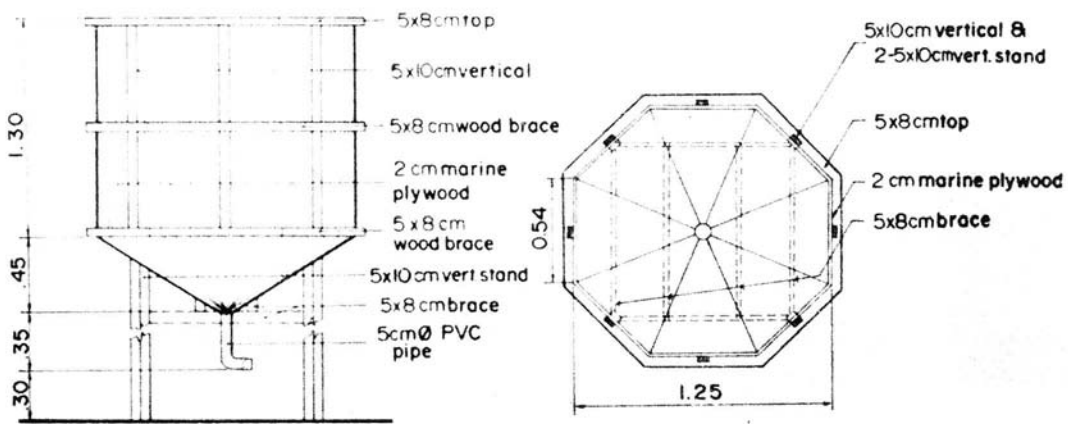

Fig. 5. Specifications of a 2-ton conical-bottom wooden larval rearing tank.

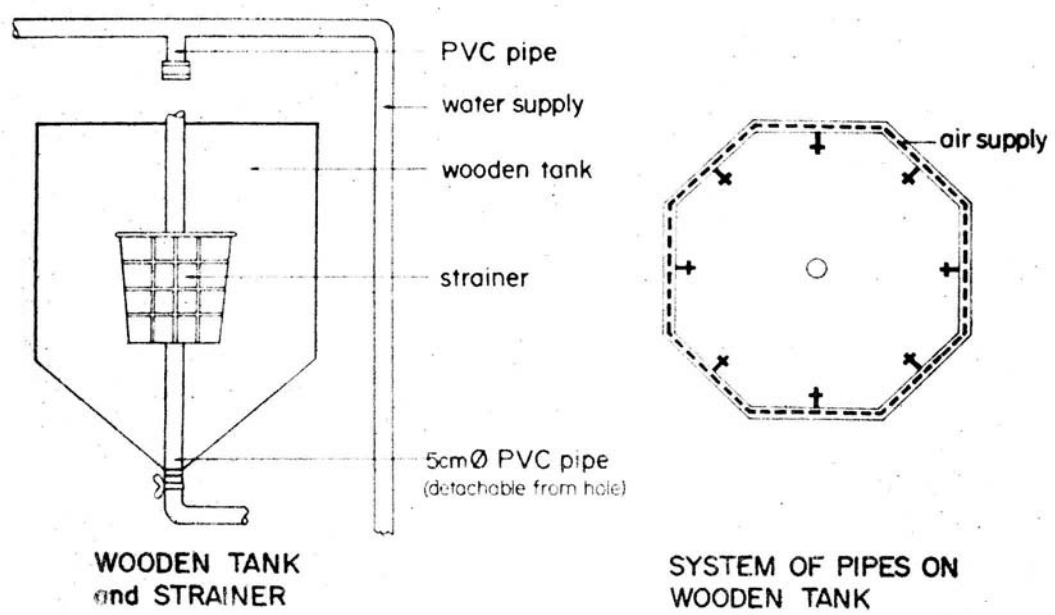

Fig. 6. Details of the larval rearing tank showing the strainer and the supply lines for water and air.

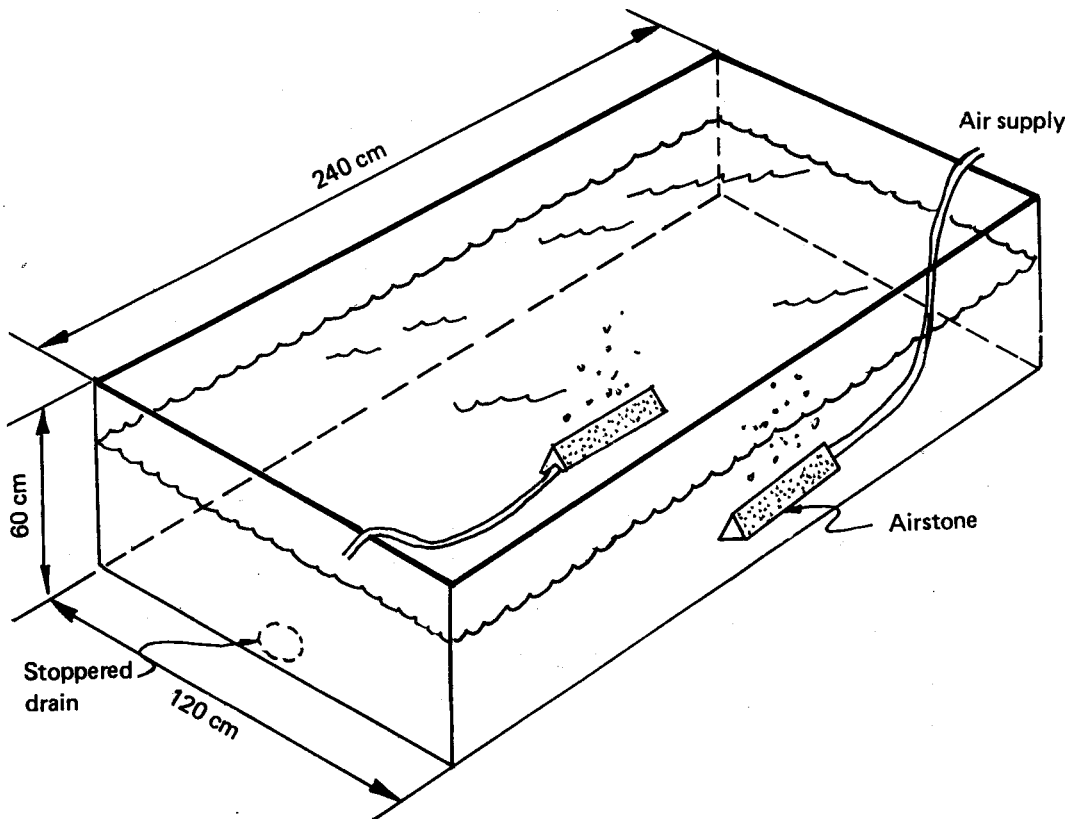

Fig. 7. One-ton wooden algal culture tank.

V. Culture of natural feeds.

1. Diatom production. Diatoms are effective feeds for the *P. monodon* larvae. A convenient species is *Chaetoceros calcitrans*. Isolation of the desired species is done by the microcapillary technique.* Then, unialgal cultures are inoculated into dextrose bottles containing the needed nutrients (Table 5).

*Stock cultures may be provided by the Aquaculture Department, SEAFDEC, Tigbauan, Iloilo, upon request.

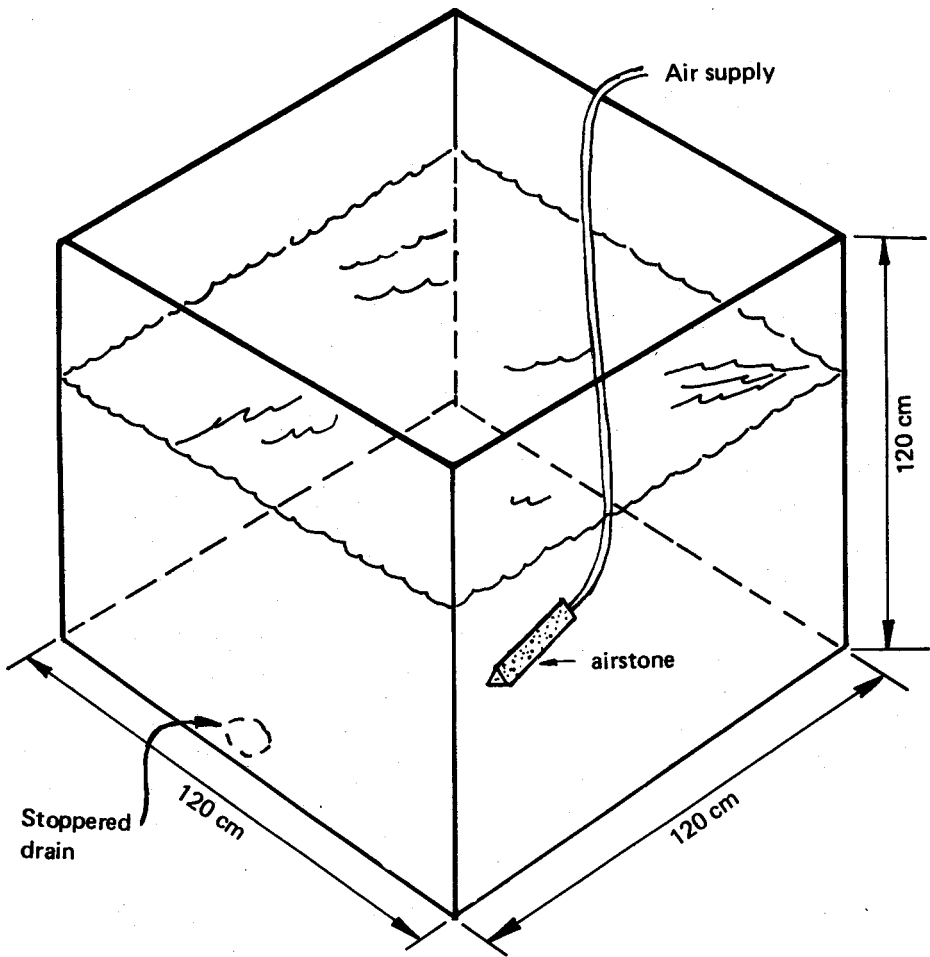

Fig. 8. One-ton wooden *Brachionus* culture tank.

Table 5. Nutrients for 1-liter stock culture of *Chaetoceros calcitrans*.

Nutrients	Concentration
Sodium nitrate	84.0 mg/L
Any one of the following:	
Monobasic sodium phosphate	10.0 mg/l
Tribasic sodium phosphate	27.6 mg/L
Calcium phosphate	11.2 mg/L
Sodium silicate	50.0 mg/L
Ferric chloride	2.9 mg/L
EDTA	10.0 mg/L
Thiamin HCl (B ₁)	0.2 mg/L
Biotin	1.0ug/L
Vitamin B ₁₂	1.0ug/L
CuSO ₄ . 5 H ₂ O	0.0196 mg/L
ZnSO ₄ . 7 H ₂ O	0.044 mg/L
NaMoO ₄ . 2H ₂ O	0.020 mg/L
MnCl ₂ . 4H ₂ O	0.0126 mg/L
CoCl ₂ . 6H ₂ O	3.6 mg/L

The volume of media is gradually increased to 3 liters with 100 mL inoculum obtained from the first stage in adequately aerated gallon jars. The nutrients used are given in Table 6.

Table 6. Nutrients for 3-liter culture of *Chaetoceros calcitrans*.

Nutrients	Concentration
Urea 46	100 mg/L
K ₂ HPO ₄	10 mg/L
Na ₂ SiO ₃	2 mg/L
FeCl ₃	2 mg/L
Agrimin	1 mg/L
EDTA	2 mg/L
Vitamin B ₁	0.005 mg/L
Vitamin B ₁₂	0.005 mg/L

Algal cultures up to this stage (gallon jars) are maintained in the algal culture room and are continuously exposed to light provided by ordinary fluorescent lamps. After 2 days, cultures from this stage with densities of 4-6 x 10⁶ cells/mL can supply the starters for the next stage.

200-L wooden tanks are used for the next stage of production. Seawater in each 200-L tank is inoculated with 3 gallon-bottles of starter obtained from the previous stage and propagated under the sun. No light is provided at night. Densities of $2-4 \times 10^6$ cells/mL can be obtained in 2 days. The nutrients added are shown in Table 7.

Table 7. Nutrients for 200-L and 1-ton cultures of *Chaetoceros calcitrans*.

Nutrients	Concentration
Urea 46	100 mg/L
Agrimin	1 mg/L
FeCl ₃	2 mg/L
16-20-0	5 mg/L
Na ₂ SiO ₃	2 mg/L
K ₂ HPO ₄ or KH ₂ PO ₄	5 mg/L

The last stage in algal production involves the use of 1-ton wooden algal tanks. An inoculum of 100 L is used in each tank. The nutrients added are the same as those used in 200-L cultures.

After 3 days of culture with light provided by the sun, the diatoms may be harvested at densities of $2-3 \times 10^6$ cells/mL.

The diatoms are first concentrated and washed in a fine sand filter before feeding into the larval rearing tanks.

The sand filter used to concentrate the diatoms consists of an 80-L plastic pail with a perforated 5-cm diameter PVC pipe as an underdrainage (Fig. 9). The pail is filled with graded gravel at the bottom and fine sand on top. The sand occupies at least four-fifths of the total volume of sand and gravel. The sand has an effective size of 0.2 mm and uniformity coefficient of 1.80. An overflow hole is provided about 8 cm from the upper surface of the sand.

Diatoms are concentrated by pumping the algal cultures evenly on top of the sand. The diatoms accumulate at the top layer of the filter. After an adequate amount has accumulated in the sand, pumping of the algal culture is stopped and clean seawater is introduced from the top to wash off the remaining nutrients. The concentrated diatoms are then flushed out and collected through the overflow hole by introducing clean seawater from the underdrain (Fig. 9).

2. *Tetraselmis* production. Another effective algal feed for *P. monodon* is *Tetraselmis chui*. The culture technique and nutrients used are similar to those used for the production of the diatom *Chaetoceros*, except that there is no need to add silicates to the culture medium.

Unlike *Chaetoceros*, *Tetraselmis* cannot be concentrated by sand filtration. Appropriate amounts of the *Tetraselmis* culture are added directly to the larval rearing tank.

3. *Chlorella* production. Pure cultures of marine *Chlorella* at a density of 1×10^7 cells/mL from 5 one-gallon bottles are inoculated into a sufficiently aerated one-ton tank filled up to one-third of its capacity with fresh seawater, and with nutrients shown in Table 10.

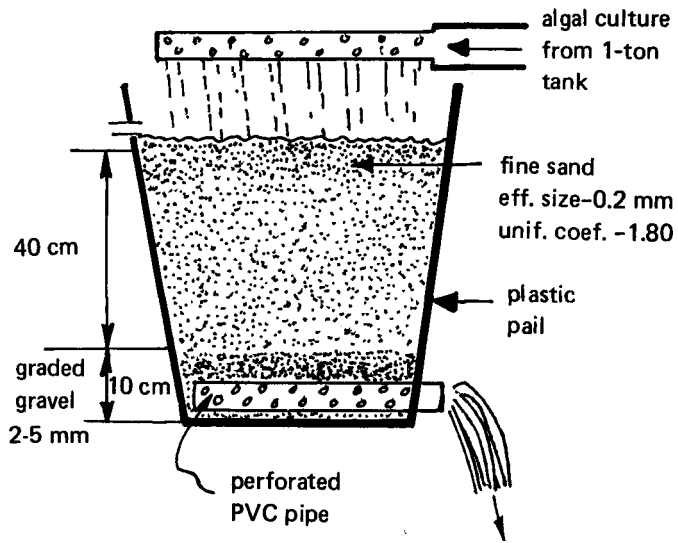

Diatom Concentration

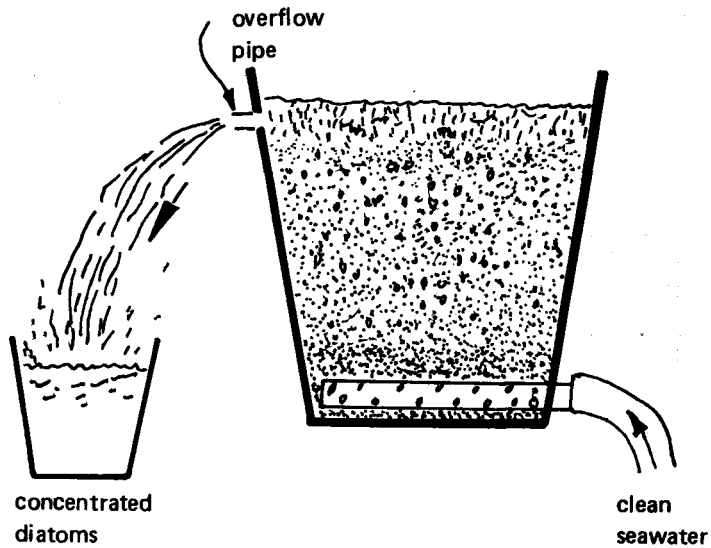

Backwashing

Fig. 9. Sand filter for concentration of diatoms.

Table 8. Program for *Chaetoceros* production.

Days of larval culture	-2	-1	0	1	2	3	4	5	6	7	8	9	10	11	12	13	14	15	16	17	18	
	Eggs hatch		N_3 to N_4	N_5 to N_6	Z_1	Z_2	Z_3	M_1 to M_5					P_1 to P_5									
Hatchery capacity																						
1 tank																						
5 tanks																						
10 tanks																						
15 tanks																						
	100	150	240	240	240	240	240	240	240	240	240	240	240	240	240	240	240	240	240	240	240	240
Number of liters of <i>Chaetoceros</i> required from 1-ton tanks per day (culture density 2×10^6 cells/mL).	500	750	1,200	1,200	1,200	1,200	1,200	1,200	1,200	1,200	1,200	1,200	1,200	1,200	1,200	1,200	1,200	1,200	1,200	1,200	1,200	1,200
	1,000	1,500	2,400	2,400	2,400	2,400	2,400	2,400	2,400	2,400	2,400	2,400	2,400	2,400	2,400	2,400	2,400	2,400	2,400	2,400	2,400	2,400
	1,500	2,250	3,600	3,600	3,600	3,600	3,600	3,600	3,600	3,600	3,600	3,600	3,600	3,600	3,600	3,600	3,600	3,600	3,600	3,600	3,600	3,600
	<p>Program of <i>Chaetoceros</i> culture in 200-L and 1-ton algal tanks:</p> <p>o-----o = 200-L tanks o-----o = 1-ton tank</p>																					
	<p>Total number of tank cultures used</p>																					
1 tank	1	2	2	2	2	2	2	2	2	2	2	2	2	2	2	2	2	2	2	2	2	2
5 tanks	1	2	2	2	2	2	2	2	2	2	2	2	2	2	2	2	2	2	2	2	2	2
10 tanks	1	2	2	3	4	4	4	4	4	4	4	4	4	4	4	4	4	4	4	4	4	4
15 tanks	1	2	3	4	4	4	4	4	4	4	4	4	4	4	4	4	4	4	4	4	4	4
1 tank	1	2	3	3	3	3	3	3	3	3	3	3	3	3	3	3	3	3	3	3	3	3
5 tanks	1	2	3	4	5	6	6	6	6	6	6	6	6	6	6	6	6	6	6	6	6	6
10 tanks	1	2	4	5	7	8	9	9	9	9	9	9	9	9	9	9	9	9	9	9	9	9
15 tanks	2	4	7	8	10	11	12	12	12	12	12	12	12	12	12	12	12	12	12	12	12	12
Daily utilization of 200-L algal tanks	10	10	10	10	10	10	10	10	10	10	10	10	10	10	10	10	10	10	10	10	10	10
Daily utilization of 1-ton algal tanks	10	16	18	18	18	18	18	18	18	18	18	18	18	18	18	18	18	18	18	18	18	18

Table 9. Program for *Tetrase/mis* production.

Days of larval culture	-1	0	1	2	3	4	5	6	7	8	9	10	11	12	13	14	15	16	17	18	
Larval stage	Eggs hatch.	N_3 to N_4	N_5 to N_6	Z_1	Z_2	Z_3	M_1 to M_3			P_1 to P_5											
Hatchery capacity				67	134	67	134	67	134	67	134	67	134	67	134	67	134	67	134	67	
1 tank				335	670	335	670	335	670	335	670	335	670	335	670	335	670	335	670	335	670
5 tanks				670	1,340	670	1,340	670	1,340	670	1,340	670	1,340	670	1,340	670	1,340	670	1,340	670	1,340
10 tanks				1,005	2,010	1,005	2,010	1,005	2,010	1,005	2,010	1,005	2,010	1,005	2,010	1,005	2,010	1,005	2,010	1,005	2,010
15 tanks																					
				<p>Number of liters of <i>Tetrase/mis</i> culture required for the larval rearing tank per day (culture density 4×10^5 cells/mL).</p> <p>Program for <i>Tetrase/mis</i> culture in 200-L and 1-ton algal tanks: 0----- = 200-L tank 0----- = 1-ton tank</p>																	
				<p>Total number of tank cultures used</p>																	
1 tank				1	2	3	3	3	3	3	3	3	3	3	3	3	3	3	2	1	14
5 tanks				2	3	3	3	3	3	3	3	3	3	3	3	3	3	3	2	1	14
10 tanks				1	2	3	3	3	3	3	3	3	3	3	3	3	3	3	2	1	14
15 tanks				1	2	3	3	3	3	3	3	3	3	3	3	3	3	3	2	1	14
1 tank				none																	
5 tanks				1	2	3	3	3	3	3	3	3	3	3	3	3	3	3	2	1	14
10 tanks				1	2	4	5	6	6	6	6	6	6	5	4	3	3	3	2	1	21
15 tanks				1	2	4	5	6	6	6	6	6	5	4	4	4	4	3	2	1	21

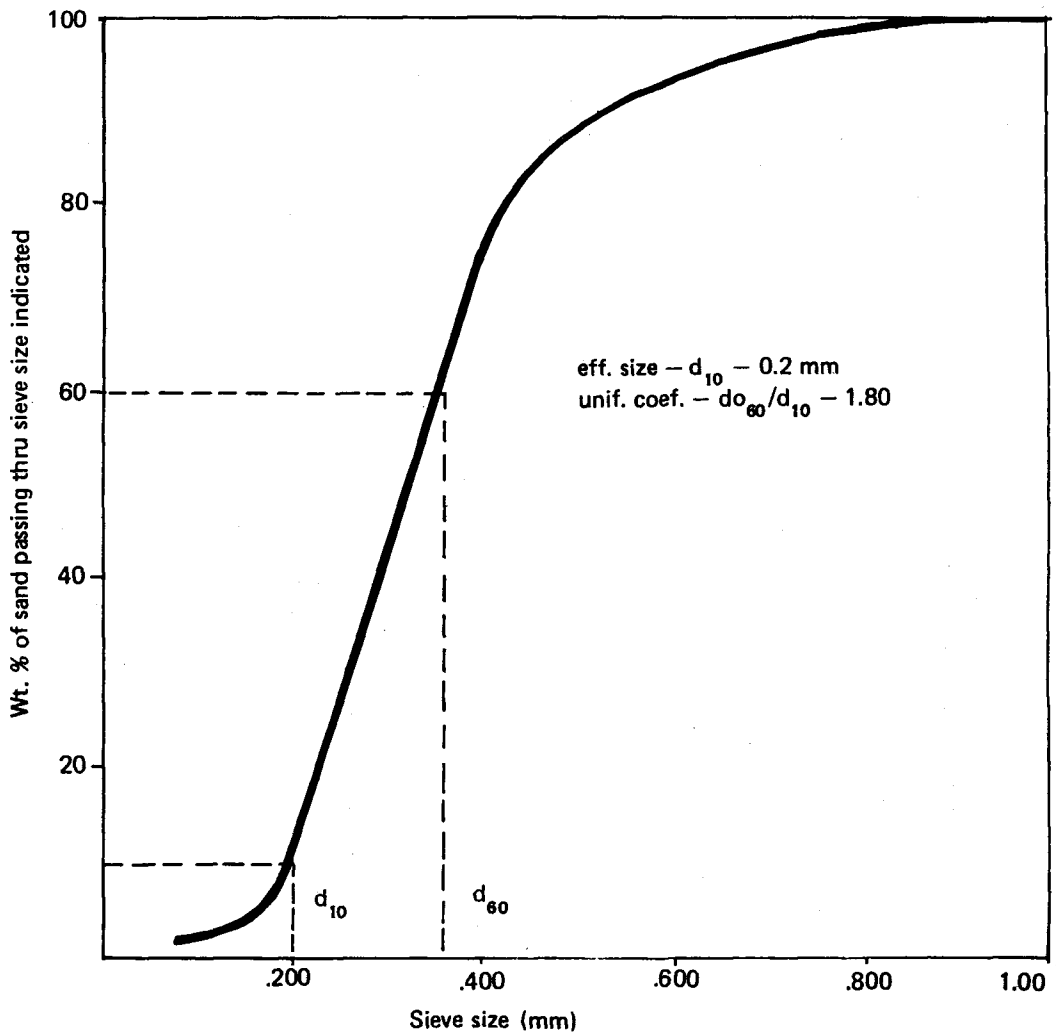

Fig. 10. Mechanical analysis of sand used as diatom filter

Table 10. Nutrients for *Chlorella* culture.

Nutrients	Concentration
21-0-0	100 mg/L
Urea 46	10-15 mg/L
16-20-0	10-15 mg/L

As the *Chlorella* cells increase in number, water is gradually added and appropriate amounts of fertilizers are applied. After 5 days a portion of the stock can be harvested to be fed to the *Brachionus* culture. An equal volume of fresh seawater is added to the remaining stock and appropriate amounts of fertilizers are also supplied. A stock of *Chlorella* can last for a considerable period if there is good water management and contamination is minimized.

4. Algal density. The density of the algae is determined by the use of a hemacytometer.

5. *Brachionus* production. *Chlorella* is first cultured until a density of 5×10^6 cells/mL is attained. Starter culture of *Brachionus plicatilis* is added at a density of 10/mL. A *Brachionus* density of 100/mL is reached in 5 to 7 days. To maintain the culture of this rotifer, pure culture of *Chlorella* is added from time to time to maintain the *Chlorella* density at 5×10^6 cells/mL. *Brachionus* is harvested by draining through a nylon net (Mesh No. 200) leaving one-third of the original volume to serve as starter for the next batch.

Brachionus density is determined by the use of a Sedgwick-Rafter counting cell or any grid plate counter.

VI. Disinfection of spawners

Spawners may carry infective agents which affect the eggs and the subsequent larval stages in the culture tanks. It is advisable to disinfect the spawners before they spawn.

Disinfection may be done by means of agents like formalin or furanace. Effective doses are 50 ppm formalin and 3 ppm furanace. The spawners are left in the disinfecting solution for 15 to 20 min when using formalin and for about 1 hr when using furanace. A maximum of 5 spawners may be disinfected in a 20-L volume.

Aeration is provided during disinfection.

The spawners are rinsed thoroughly with clean seawater before placing them in the spawning tanks.

VII. Spawning and hatching

After disinfection, the spawners are placed in spawning tanks which may range from 100 to 300 L in volume. The water used for spawning should be clean to avoid infection of eggs. It is recommended that only one spawner be placed in each spawning tank. Thus, the fecundity and hatching rate of eggs per spawner can be determined.

The hatching rate is a gross measure of the quality of the eggs. Eggs with hatching rates lower than 30% are not ideal for rearing.

Gravid *P. monodon* normally spawn at night. The spawning tanks should be shielded from light by means of black cloth or some other material that can provide the same effect. Aeration should be moderate. Water temperature should be about 28°C.

A common evidence of spawning is the appearance of yellow-orange scum on the water surface or attached to the walls of the tank. However, some spawners do not exude this yellow-orange substance so that it is necessary to sample a portion of the water in transparent beakers or cups and to look for the eggs. The morning or the day after spawning has taken place, the spawner is removed and the spawning debris scooped from the water with a coarse net; the eggs are left in the tank. The eggs are thoroughly washed by continuously running about 100L of water into the tank while also siphoning

out about the same amount. A strainer is used to prevent the eggs from being drained out. Cleaning may also be done by carefully concentrating the eggs with the use of fine mesh net and placing them in another tank with fresh clean seawater. Aeration should be moderate. Egg count in a sample volume should be made.

The eggs hatch to nauplii 12 to 15 hr after spawning. However, not all eggs hatch at the same time. To determine the hatching rate, the count of the nauplii may be made in the morning of the following day. Normally, the hatching rates of eggs from good spawners range from 60 to 98%.

VIII. Rearing in larval culture tank

It is convenient and less stressful to the larvae to transfer them into the larval culture tank (2-ton conical bottom tank) while still in the N₁ substage. Stopping aeration in the tank will allow the nauplii to concentrate on the surface. These are then scooped by pail and carefully transferred into the larval culture tank previously stocked with 1 ton clean seawater. The larval culture tank may be stocked at initial densities ranging from 50,000 to 100,000 nauplii per ton. Higher stocking densities require more careful water management and a more intensive diatom feeding.

The volume of water in the tank is gradually increased by adding about 200 L of clean seawater daily.

About 2 days after hatching, the nauplii metamorphose into zoeae. This is the stage when the larvae start to feed. Initial feeding should be programmed so that there is available food shortly before the nauplii metamorphose to zoeae.

Suggested feeding levels are shown in Table 11. The desirable water temperature is about 28°C throughout the culture period. Much lower temperatures delay molting from one stage to the next.

Table 11. Feeding schedule for *P. monodon* larvae.

Culture Period (days)	0	1	2	3	4	5	6	7	8	9	10	11	12	13	14	15	16	17	18
Larval stage	Nauplius		Zoea			Mysis			Postlarva										
			Z ₁	Z ₂	Z ₃	M ₁	M ₂	M ₃	P ₁ to P ₅										
<i>Chaetoceros</i> , cells/mL			30,000	50,000	80,000	80,000	80,000	80,000											
<i>Tetraselmis</i> , cells/mL				5,000	10,000	20,000	20,000	20,000											
Rotifer (<i>Brachionus</i>)/mL							5	8	10										
Brine shrimp/mL																5			

Water management in larval culture tanks depends on several factors such as concentration of metabolites, diatom density, occurrence of infection and amount of particulates. Changing of water is done by using a strainer.

After molting from the nauplii the zoeae take about 5 to 6 days before molting to the mysis stage.

Once the zoeae metamorphose into mysids, one-half to two-thirds of the water should be changed daily. The three mysis substages require about 4 to 5 days, after which the larvae become postlarvae.

Hatched brine shrimp or finely ground fish meat provide the major diet of *P. monodon* in the early postlarval stages (P₁ to P₅). Algae are also supplied to help enhance water quality.

The fry at P₅ may already be harvested for stocking in nursery ponds.

IX. Harvesting technique

Harvesting is done by first draining out three-fourths of the volume of water in the tank. A strainer is used to prevent the fry from being drained out. The drain valve is then opened slowly and the contents discharged into a 150-L harvesting box. The upper one-fourth portion of the walls of the harvesting box is fitted with plastic screen to allow the water to overflow while retaining the fry inside.

X. Pre-treatment and transport

Before transport, the fry are first held at a temperature 5°C lower than the water temperature in the tank. This is done by introducing previously frozen seawater. The fry are held at this temperature for 30 to 60 min. The temperature is further decreased to about 20°C before the fry are packed in 50 x 90 cm plastic bags. An estimated 20,000 fry can be packed in one plastic bag containing 16 L of chilled seawater.

The plastic bag containing the fry is pumped with oxygen and the mouth is firmly tied with rubber bands. The fry contained in bags are shipped in styrofoam boxes for stocking in the ponds.

XI. Economics of a small-scale hatchery

Assumptions:

1. All tanks (for rearing of larvae, algae, and *Brachionus*) and reservoirs are made of marine plywood.
2. Electrical power is available.
3. Seawater salinity is within the desirable range of 28 to 32 ppt
4. Pumping of seawater through the filter into the reservoir is done only once a day for a period of 4 hr.
5. Blower or compressor is operating 24 hr a day.
6. there are 14 runs per year, one run lasting for 16 to 18 days.
7. One spawner costs P100.

8. One spawner produces 300,000 eggs, of which 200,000 will hatch to nauplii.

9. Stocking density is 100,000 nauplii per larval rearing tank.

10. A survival rate of 30% from nauplius to postlarva, or a production of 30,000 postlarvae per tank.

11. The postlarvae sell at P80 per thousand.

12. A loan equivalent to the initial investment, plus 50% of the annual operating and maintenance cost, is subjected to 14% interest rate.

13. 5% of the net income is paid as tax.

14. The economic life of all physical facilities and equipment is 3 years.

Table 12. Cost of physical facilities and equipment for different hatchery capacities.

Hatchery capacity	1 tank	5 tanks	10 tanks	15 tanks
1. Larval rearing tanks (2-ton) at P2,000.00	2,000	10,000	20,000	30,000
2. Support tanks				
a) <i>Chaetoceros</i> culture tanks (1-ton) at P1,100	3,300	6,600	9,900	13,200
b) <i>Tetraselmis</i> culture tanks (1-ton) at P1,100		3,300	6,600	6,600
c) <i>Brachionus</i> tanks at P1,000	1,000	3,000	6,000	8,000
d) <i>Chlorella</i> culture tanks at P1,100	2,200	2,200	2,200	3,300
e) 200-liter tanks at P400	2,000	2,000	2,800	2,800
3. Air blower/compressor, 2 units	10,000	15,000	20,000	26,000
4. Water pump, 3 units	3,000	6,000	7,500	9,000
5. Diatom pump, 1 unit	1,000	1,000	1,000	1,000
6. Building (including concrete, open, algal culture area)	17,800	26,000	39,950	52,000
7. Well point/water intake structure	500	1,000	2,000	3,000
8. Air and water distribution lines, lighting	6,000	15,000	23,000	28,000
9. Sand filter (for seawater supply)	500	650	1,000	2,800
10. Reservoirs				
a) Seawater	1,500	4,000	8,000	12,000
b) Fresh water	500	1,000	1,600	2,000
11. Microscope	4,000	4,000	4,000	4,000
12. Refractometer	3,000	3,000	3,000	3,000
Total	58,300	103,750	158,550	206,700

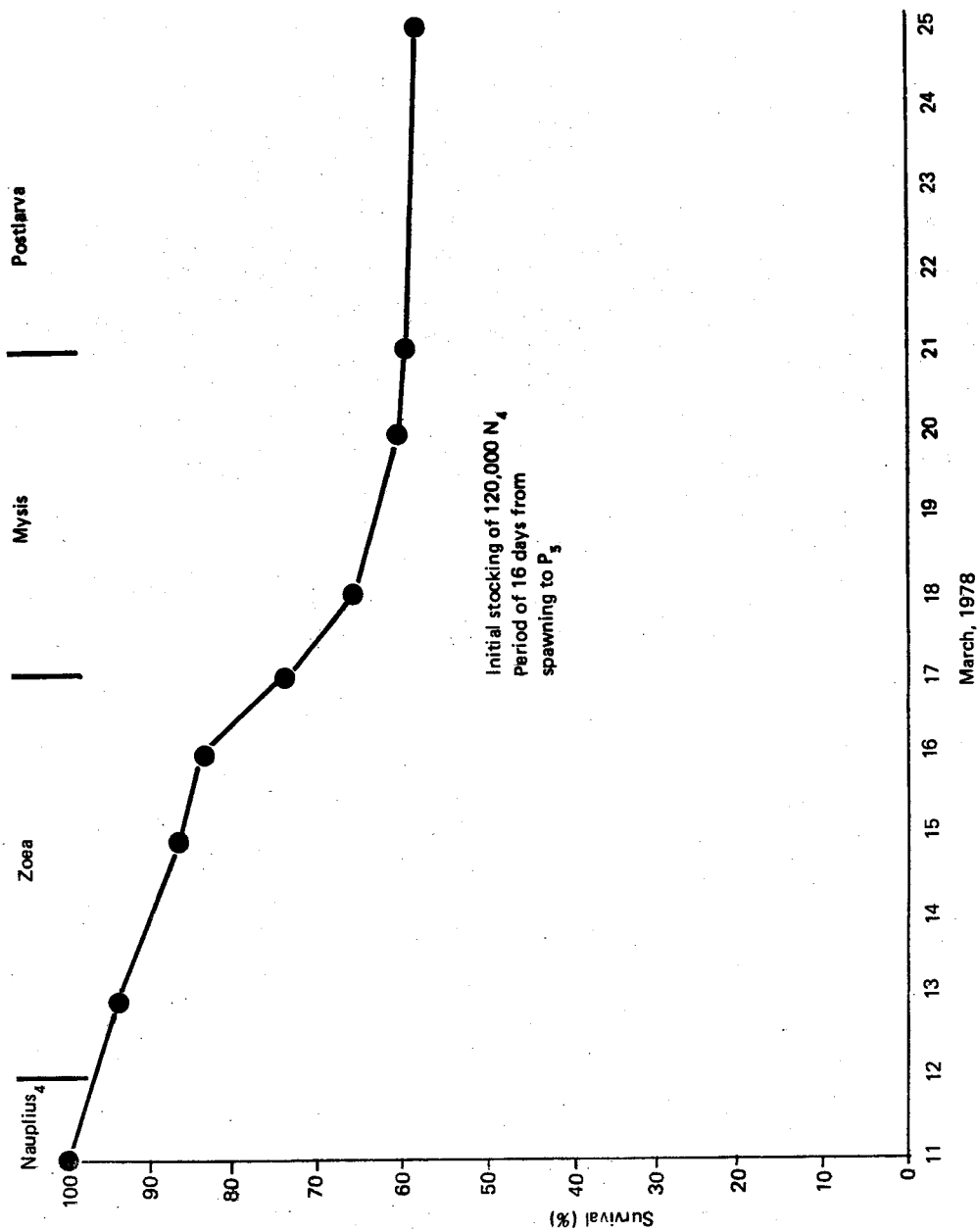

Fig. 11. Survival rate curve for *P. monodon* in an experimental run using 2-ton conical bottom wooden tank.

Table 13. Operating and maintenance expenses for different hatchery capacities
(in pesos per annum).

Hatchery capacity	1 tank	5 tanks	10 tanks	15 tanks
1. Salaries				
a) Fishery Technician at P800 month	9,600	9,600	19,200	19,200
b) Aides at P400/month	4,800	14,400	19,200	24,000
2. Supplies and materials				
a) fertilizers	475	555	665	925
b) brine shrimp	882	4,410	8,820	13,230
c) other materials (nets, tubings, hose, glasswares)	3,725	6,750	12,475	18,200
3. Power and electricity				
a) water pump (4-hr operation per day)	53	158	316	421
b) air blower/compressor	2,943	5,580	9,750	13,000
c) lighting	2,943	3,066	4,415	4,905
4. Spawners at P100 each	1,400	4,200	7,000	11,200
5. Maintenance and repair of physical facilities and equipment (5% of initial investment)	2,915	5,187	7,928	10,335
Total	29,736	53,906	89,769	115,416

Table 14. Production cost and income^a for different hatchery capacities
(in pesos per annum).

Hatchery capacity	1 tank	5 tanks	10 tanks	15 tanks
I — Initial capital investment	58,300	103,750	158,550	206,700
II — Operating and maintenance expenses	29,736	53,906	89,769	115,416
III — Fixed costs				
a) depreciation (33.3% of initial investment)	19,414	34,549	52,797	68,831
b) taxes (5% of net income)		2,931	7,878	13,500
c) 14% interest on loan (amount of loan is initial investment and 50% annual operating and maintenance expenses)	10,146	18,004	27,991	36,233
IV — Total production cost	59,296	109,390	178,435	233,980
V — (Annual postlarvae production)	(420,000)	(2,100,000)	(4,200,000)	(6,300,000)
VI - Production cost per postlarva	0.14	0.052	0.042	0.037
VII — Gross income (from sale of postlarvae at P80 per thousand)	33,600	168,000	336,000	504,000
VIII — Net income	-	58,610	157,565	270,020
IX — Return on investment	-	56.5%	99.4%	130%

^a For a production of 30,000 postlarvae from one larval rearing tank per run and a total of 14 runs in one year.

Table 15. Itemized unit requirement for different hatchery capacities.

	1 tank	5 tanks	10 tanks	15 tanks
1. Larval rearing tanks (2-ton capacity)	1 tank	5 tanks	10 tanks	15 tanks
2. Support tanks				
a) <i>Chaetoceros</i> culture tanks (1-ton)	3	6	9	12
b) <i>Tetraselmis</i> culture tanks (1-ton)	—	3	6	6
c) <i>Brachionus</i> culture tanks (1 ton) for 3 culture periods per run	1	3	6	8
d) <i>Chlorella</i> tank (1 ton)	2	2	2	3
e) 200-L tanks (<i>Chaetoceros</i>)	2	2	4	4
f) 200-L tanks (<i>Tetraselmis</i>)	3	3	3	3
g) Gallon bottles (<i>Chaetoceros</i>)	6	6	12	12
h) Gallon bottles (<i>Tetraselmis</i>)	6	6	6	6
i) Dextrose bottles	6	6	9	9
3. Air blower or compressor (kW)	2 (0.48)	2 (0.91)	2 (1.59)	2 (2.12)
4. Water pump (kW)	3 (0.0746)	3 (0.224)	3 (0.448)	3 (0.597)
5. Water pump for diatoms (0.0746 kW)	1	1	1	1
6. Reservoir	1 (1.5 tons)	1 (6 tons)	2 (6.25 tons)	2 (9.25 tons)
7. Filter (surface area, sq m)	1 (0.3 sq m)	1 (1 sq m)	1 (1.7 sq m)	1 (2.5 sq m)
8. Microscope	1	1	1	1
9. Refractometer	1	1	1	1

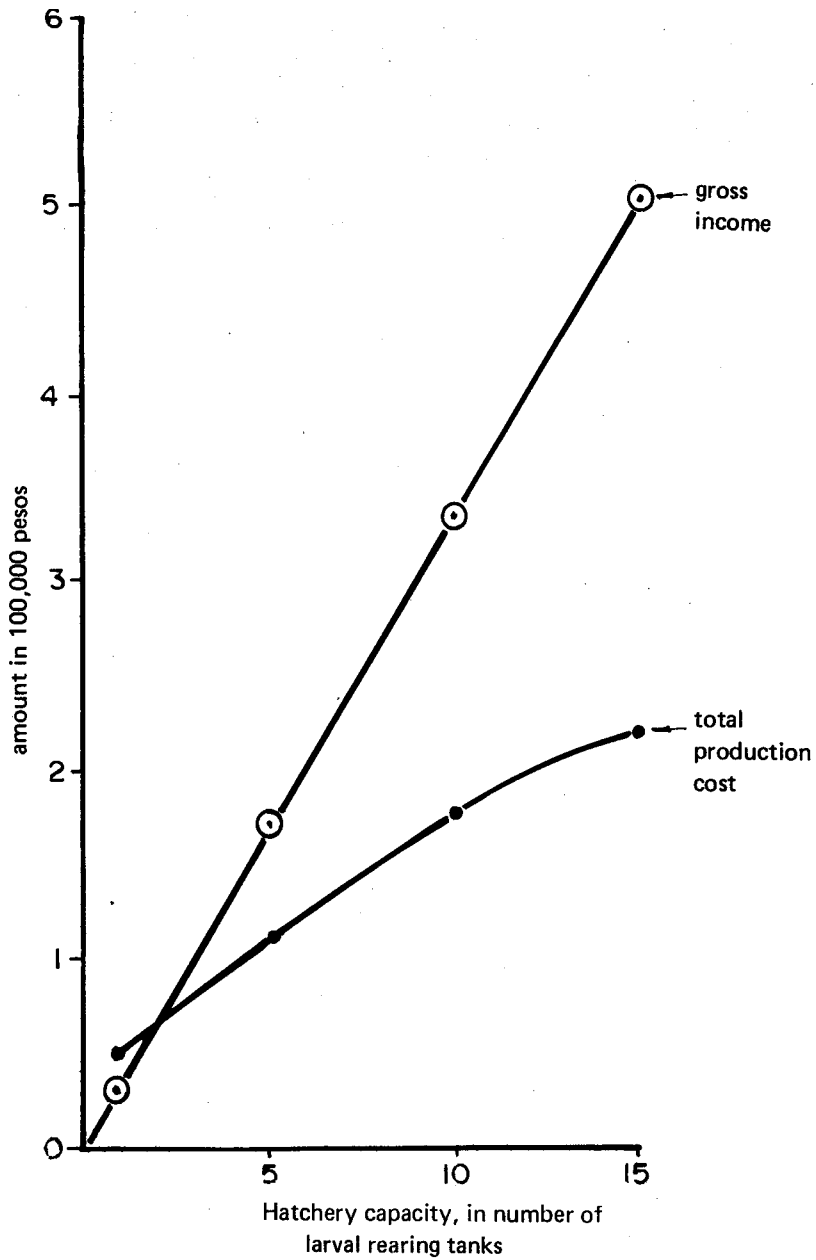

Fig. 12. Relationship of production cost and gross income to hatchery capacity.

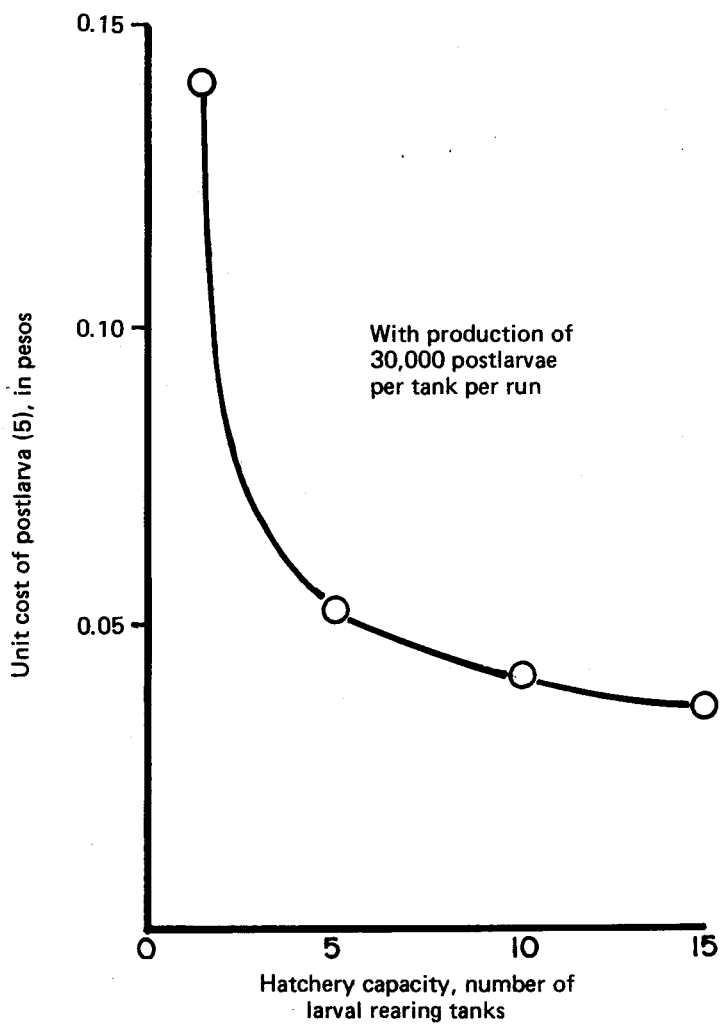

Fig. 13. Relationship of unit cost of postlarva to hatchery capacity.

Suggested Further Readings

1. Aquacop, 1977. Elevage larvaire de peneides en milieu tropical. Groupe de travail aquaculture, ICES, 10-13 mai Brest, France, 11 pp.
2. Cook, H. L. 1976. Problems in shrimp culture in the South China Sea region. Manila, South China Sea Fisheries Development and Coordinating Programme.
3. Fair, G., J. Geyer, and D. Okun. 1966. Water and wastewater engineering, vol. 2. John Wiley and Sons, Inc. New York.
4. Gloyna E. and W. Eckenfelder Jr. (editors). 1968. Advances in water quality improvement. University of Texas Press.
5. Mock, C. R. and M. Murphy. 1971. Techniques for raising eggs to postlarvae. Proceedings, First Annual Workshop, World Mariculture Society.
6. Mock, C. R. and R. A. Neal. 1974. Penaeid shrimp hatchery systems. FAO/CARPAS Symposium on Aquaculture in Latin America, Montevideo, Uruguay.
7. Motoh, H. 1978. The larval stages of the giant tiger prawn, *Penaeus monodon*, reared in the laboratory. Unpublished manuscript.
8. Neal, R. A. 1976. Penaeid shrimp culture research at the National Marine Fisheries Service, Galveston Laboratory. FAO Technical Conference on Aquaculture, Kyoto, Japan.
9. Primavera, J. H., E. Borlongan, and R. A. Posadas. 1978. Mass production in concrete tanks of sugpo, *Penaeus monodon* Fabricius spawners by eyestalk ablation. Fish. Res. J. Phil., 3:____(in press).
10. Salser, B. R. (n. d.) Equipment used for the culture of larval penaeid shrimp at the National Marine Fisheries Service, Galveston Laboratory, Galveston, Texas.
11. Scheel, L. F. 1961. Gas and air compression machinery. McGraw-Hill Book Company, New York.
12. Suñaz, F. P. 1978. *Chaetoceros calcitrans* as larval food for cultured marine organisms - a culture method. Unpublished manuscript, 14p.
13. Villaluz, D. K., A. C. Villaluz, B. Ladrera, M. Sheik and M. Gonzaga. 1972. Reproduction, larval development, and cultivation of sugpo (*Penaeus monodon* Fabricius). Phil. J. Sci.,98 (3-4): 205-233.
14. Yang, W. T. 1975. A manual for large-tank culture of penaeid shrimp to the postlarval stages. Coral Gables, University of Miami, Sea Grant Program.
15. Yap, W. G. 1977. Cultivation of live feed for the rearing of sugpo (*Penaeus monodon*) larvae. Paper presented at the Conference on Aquaculture on the Cultivation of Fish Fry and its Live Food, Szymbark, Poland, Sept. 23-28.

List of Figures

- Fig. 1 Life cycle of *P. monodon*
- Fig. 2 Appearance of the ovarian mass at different stages of maturity
- Fig. 3 Layout of a small-scale hatchery system
- Fig. 4 Cumulative water consumption for different hatchery capacities
- Fig. 5 Specifications of a 2-ton conical-bottom wooden larval rearing tank
- Fig. 6 Details of the larval rearing tank showing the strainer and the supply lines for water and air
- Fig. 7 One-ton wooden tank for algal culture
- Fig. 8 One-ton wooden tank for *Brachionus* culture
- Fig. 9 Sand filter for concentration of diatoms
- Fig. 10 Mechanical analysis of sand used as diatom filter
- Fig. 11 Survival rate curve for *P. monodon* in an experimental run using 2-ton conical-bottom wooden tank
- Fig. 12 Relationship of production cost and gross income to hatchery capacity
- Fig. 13 Relationship of unit cost of postlarva to hatchery capacity

List of Tables

- Table 1 Seawater and pump requirements for different hatchery capacities
- Table 2 Compressed air requirements for different hatchery capacities
- Table 3 Algal and *Brachionus* tank requirements for different hatchery capacities
- Table 4 Area requirements of a hatchery installation for different capacities
- Table 5 Nutrients for 1-liter stock culture of *Chaetoceros calcitrans*
- Table 6 Nutrients for 3-liter culture of *Chaetoceros calcitrans*
- Table 7 Nutrients for 200-liter and 1-ton cultures of *Chaetoceros calcitrans*
- Table 8 Program for *Chaetoceros* production
- Table 9 Program for *Tetraselmis* production
- Table 10 Nutrients for *Chlorella* culture
- Table 11 Feeding schedule for *P. monodon* larvae
- Table 12 Cost of physical facilities and equipment for different hatchery capacities
- Table 13 Operating and maintenance expenses for different hatchery capacities
- Table 14 Production cost and income for different hatchery capacities
- Table 15 Itemized unit requirements for different hatchery capacities

A C K N O W L E D G M E N T

The author wishes to express his gratitude to Dean D. K. Villaluz, Department Chief, Dr. Q. F. Miravite, Executive Director, Dr. J. A. Eusebio, Research Director, Atty. J. M. Garay, Director for Development and Administrative Services, Mr. Wilfredo Yap, Prawn Program Leader, and Atty. J. A. Agbayani, Jr., Head, Training and Extension Division, for their encouragement and support, and to Mrs. Jurgenne H. Primavera and Mr. H. Motoh for their helpful comments and suggestions. Thanks are also due to Mr. G. Loable for editing the manuscript; Mr. H. Juntaria for the drawing of text figures; and Miss A. Loresto for typing the drafts.

The Barangay Hatchery Team

Rolando R. Platon - Project Leader
Hideo Mochizuki — Expert

Technology Transfer Group

1. Bernardo Padayao
2. Lolito Dullin
3. Guillermo Semorlan
4. Genaro Insoy
5. Edmundo Perando
6. Erlito Langam

Technology Development Group

1. Joy Lao
2. Eduardo Buenavides
3. Romeo Caturao
4. Edgardo Samane
5. Fred Torrento
6. Eutiquio Maloloy-on

The Southeast Asian Fisheries Development Center (SEAFDEC) is an international treaty organization devoted to the development of aquaculture in the region — under an agreement among Japan, Malaysia, the Philippines, Singapore, Thailand and Vietnam. SEAFDEC has three departments, namely, the Training Department in Thailand, the Marine Fisheries Research Department in Singapore, and the Aquaculture Department in Iloilo, Philippines.



AQUACULTURE DEPARTMENT
SOUTHEAST ASIAN FISHERIES DEVELOPMENT CENTER

Tigbauan, Iloilo, Philippines