

Southeast Asian Fisheries Development Center

Aquaculture Department

SEAFDEC/AQD Institutional Repository

<http://repository.seafdec.org.ph>

Journals/Magazines

Aqua Farm News

1990

Aqua Farm News Volume 08(03) May - June 1990

Aquaculture Department, Southeast Asian Fisheries Development Center

<http://hdl.handle.net/10862/75>

Downloaded from <http://repository.seafdec.org.ph>, SEAFDEC/AQD's Institutional Repository

AQUA



ISSN 0116-6573

FARM NEWS

Produced by Audiovisual-Print Section
Training & Information Division
SEAFDEC Aquaculture Department

Vol. VIII No. 3
May-June 1990

IN THIS ISSUE:

HATCHERY SYSTEMS, p. 1

OPERATING A MILKFISH HATCHERY, p. 3

- Tanks and Equipment, p. 3
- Packing and Transporting Milkfish Eggs, p. 5
- Preparing Hatching and Larval Rearing Tanks, p. 6
- Hatching Milkfish Eggs, p. 7
- Food Organisms for Milkfish Larvae, p. 7
- Larval Rearing, p. 7
- Harvesting Milkfish Larvae, p. 9

ECONOMICALLY IMPORTANT SEAWEEDS OF PANAY ISLAND, p. 10

REDUCING AQUACULTURE FEED COSTS IN THE TROPICS, p. 11

THIRTEEN GRADUATE FROM AQUAMANAGEMENT, p. 11



“Better life through aquaculture”

Aqua Farm News is published bimonthly by
Audiovisual-Print Section, Training and Information Division
Aquaculture Department
Southeast Asian Fisheries Development Center
P.O. Box 256, Iloilo City, Philippines

ISSN 0116-6573

In citing information from **AFN**, please cite the institutional source which, in some articles, is not necessarily SEAFDEC Aquaculture Department. Mention of trade names in this publication is not necessarily an endorsement.

Subscription rates:

Local - ₱40.00 per year

Foreign - US\$26.00 per year (including air mail postage)

Please make remittances in Postal Money Order/Bank Draft/Demand Draft payable to **SEAFDEC Aquaculture Department**

Editor: **J. Lagoc**
Associate Editor: **M. Castaños**
Production: **R. Tenedero**
A. Surtida
L. Plondaya
R. Buendia
D. Badilles
J. Requintina
E. Ledesma
Circulation: **E. Aldon**
L. Tabigo-on, Jr.
Consultant: **I.J. Dogma, Jr.**

HATCHERY SYSTEMS

The mortality rate during the larval phase is significantly higher compared to the other phases of culture operations. The survival rate of eggs and larvae is particularly important where fecundity of fish is low. For these reasons, the development of indoor hatchery systems - where female broodstocks spawn, the eggs fertilized and hatched, and the fry grow until strong enough for stocking - is highly desirable. In such systems, the early stages of the life cycle are carried out in a controlled environment where the quality and temperature of the water, the amount of light and other factors including disease and feeding are closely monitored to ensure optimal living conditions.

The rapid growth of the aquaculture industry, concurrent with new technological endeavors and scientific breakthroughs inbreeding, has led to an increasing but still insufficient and inconsistent fry supply. The development of good hatchery systems to cope with the rising demand for fry is, thus, indispensable.

Site selection. When establishing a hatchery, particularly a large-scale modern hatchery, the criteria for site selection must be rigidly followed considering the high financial input. Some of the more important criteria include:

- *Quality and source of water.* The water to be used in hatcheries should be clean, pollution-free and of good and stable quality throughout the year.

In the case of water supply for a tropical freshwater fish/shrimp hatchery, the following are considered ideal: an average temperature of 24 - 31°C; pH, 7 - 8.5; dissolved oxygen (DO), >5 ppm; hardness, >20 ppm; turbidity, <50 FTU; BOD, <1 ppm; ammonia, <0.1 ppm; nitrite, 0.02 ppm; and trace amounts of heavy metals and no pesticides. For marine fish and brackishwater shrimp, besides these prerequisites, a salinity range of 28 - 33 ppt is also recommended.

- *Climatic conditions.* Hatcheries should be established in areas where temperature/humidity do not fluctuate excessively. In addition, the land elevation should be high enough to prevent flooding.

- *Facilities.* Electricity is essential to life-supporting systems and other hatchery equipment. Pumps and aerators can be driven by generators in areas without electricity although it is more economical to operate hatcheries in areas with a reliable source of electricity. The installation of an on-site standby generator is, nevertheless, absolutely necessary.

Easy accessibility should also be ensured all year-round to facilitate communication and transportation of equipment, supplies and fingerlings.

Finally, the presence of spawners at the vicinity of the proposed site to ensure a consistent supply especially for those species of which full artificial reproduction cycle has not been mastered is advantageous.

Design and Construction. For economic reasons, hatchery design should be simple, compact, and easy to operate with maximum efficiency. Principles of sanitation and hygiene should be followed in the design and construction since fish/shrimp larvae are usually very susceptible to disease.

There is no standard format for the layout of a hatchery. Similarly, there is no limitation on the size of a hatchery. For optimal health conditions and control reasons, the hatchery layout

2 *Aqua Farm News VIII (3)May-June 1990*

should be "compartmentalized". The different sections should have separate water supplies, and cleaning material; and care should be taken to disinfect all equipment before reuse.

It is desirable that all materials used in the construction of hatcheries be locally available, low-priced, and durable. Examples: wood, concrete, reinforced concrete, ferro-concrete, fiberglass, and wood with plastic lining.

Management and operation. The management and operation of hatcheries usually follow similar lines, although there are slight variations depending on species cultured and scale of operation.

- *Broodstock development and spawning.* Fish/shrimp selected for broodstock should be fast-growing, active, healthy and among the largest and strongest individuals of their age group.

Broodstock are usually kept in maturation tanks until spawning time. There are various ways in which spawners are induced to spawn, from semi-natural methods involving, for example, raising the water level in tanks, photoperiodic induction and eyestalk ablation as practiced for shrimp, to completely artificially induced breeding by injecting spawners with hormones. Egg collection can then take place by natural means or by stripping. In the latter technique, the female is held by the operator out of the water and the ripe eggs carefully stripped off. The eggs are then gently mixed with previously collected male sperms. The addition of a small amount of water will trigger the fertilization process.

- *Incubation.* After fertilization, the eggs of the different species are put in incubators. Eggs require a constant supply of consistently good quality water, if optimum hatch rates and survival of fry are to be attained. The ideal incubator design is a water flowthrough system - in one end and out the other. The outflow can either be recirculated through a biological filter or be discharged. Flow rates vary, depending on the buoyancy of the eggs and/or their susceptibility to mechanical stress.

- *Hatching.* Hatching normally takes place in the incubator. Depending on the species, it can take from a few hours to a few days until all the eggs of one batch have hatched. After hatching, the hatchlings have to be separated from the egg shells to prevent occurrence of disease. The hatchlings which are still attached to their egg yolk sac from birth are then placed in a small tank or container. When the egg yolk sac is almost empty, the swim bladder becomes operational and the larvae go to the surface for air. Fins and tail are moving, the mouth and anus have been formed and from now on the larvae have to be fed.

- *Larval rearing.* The tanks used for the primary phases of larval rearing could be built from concrete, reinforced polyester or fiberglass. Smooth flow of water in the tank must be ensured to facilitate ample oxygen availability for the larvae. The types of tanks used will depend on the species to be farmed. Two examples of differently designed larval rearing tanks are: a rectangular tank with a sloping bottom and a circular tank in which the water flows as a spiral from the outer edge to the center. The system is "self cleaning", the dirt being sucked into a drainage point in the center. This system is used, for example, for salmonids which prefer to swim against the current.

- *Water management and monitoring.* Clear water is generally used for rearing of larvae. Except in recirculation systems, about 20-60 percent of the rearing water is usually changed daily, with concomitant siphoning of bottom wastes. Maintenance of salinity is very important for marine species particularly shrimp. Care should also be taken to avoid temperature fluctuations, and regular monitoring of larvae health is imperative.

- *Feeds and feeding.* Availability of good quality feed and proper feeding technology are crucial for the success of a hatchery. Feeds may contribute up to 60 percent of the operational costs of a hatchery. Characteristics of feeds suitable for fish larvae are: acceptability to fish, proper size, high dietary value especially highly unsaturated fatty acids, and easy to mass produce. Live food is usually preferred to commercially available feed in the initial stages of larval development.

Mollusc larvae is the primary starter feed for fish larvae. In addition, selected phytoplankton

such as *Chlorella*, *Tetraselmis* and *Isochrysis* as well as rotifers are also suitable.

For shrimp larvae, diatoms and *Tetraselmis* are particularly suitable for feeding of zoea followed by *Artemia* for mysis. In the later stages, *Artemia* and/or pellets are used.

- *Diseases and their control.* Disease outbreaks could be controlled through proper cleaning and adoption of good sanitation and hygiene practices throughout hatchery operations. Various drugs are available in the market for controlling disease outbreaks including malachite green or treflan, chloramphenicol, oxytetracycline (OTC), and formalin. Proper nutrition and water quality maintenance to prevent disease are, however, more important than control itself.

- *Harvesting.* Harvesting of fish/shrimp larvae should be carefully done using a scoop net or bag net.

- *Transportation.* The mode of transport varies slightly with species and distance involved. Various containers could be used, such as polyethylene bags and bamboo baskets. The use of clean water, and the incorporation of antimetabolites and other suitable chemicals are considerations for reducing mortality.

Source: Gerald L. Roessink, **INFOFISH International**, September-October 1989.

OPERATING A MILKFISH HATCHERY

Mass production of milkfish fry is now possible!

The technology for operating a milkfish hatchery has come of age after over a decade of research work on milkfish at SEAFDEC/AQD: from the development of broodstock technology; to induction of spawning and larval rearing since 1977; to regular spontaneous spawning of broodstock in captivity during the breeding season since 1980; to completion of the life cycle in 1983; to development of techniques for collection of spawned eggs in 1986.

The supply of wild milkfish fry is often unpredictable and the catch in recent years has apparently diminished. Moreover, the recent trend toward semi-intensive culture is expected to create a heavier demand for fry which may not be met by the supply from traditional sources. Hatchery production of fry can stabilize the supply of seeds and eventually promote increased production of milkfish, an important food fish in the Philippines.

Naturally spawned milkfish eggs may be secured from the SEAFDEC Aquaculture Department and from the National Bangus Breeding Program (NBBP) project sites of BFAR in Alaminos, Pangasinan; Calape, Bohol; and Sta. Cruz, Davao del Sur.

Item One: Tanks and Equipment

A milkfish hatchery needs larval rearing tanks, culture tanks for rotifer (*Brachionus*) and green algae (*Chlorella*), and hatching tanks for the brine shrimp (*Artemia*). A volume ratio of 1 ton larval rearing tank to 3 tons algal and rotifer tank is recommended. Tanks should be easily drained through a harvesting canal. A layout of a typical milkfish hatchery is shown in Figure 1.

Larval Rearing Tank. Circular canvas or concrete tanks with an airstone at the center may be used. Larger tanks may be used; however, tanks of smaller volumes are preferred for easy management. Larval rearing tanks should be placed under a shade to protect the larvae from the glare and heat of direct sunlight and to deter growth of diatoms that contribute to poor water quality.

Algal/Rotifer Tank. Square, rectangular or circular canvas or concrete tanks may be used for mass production of *Chlorella* and *Brachionus*. To maximize tank usage, tanks for algae are also used to culture rotifer.

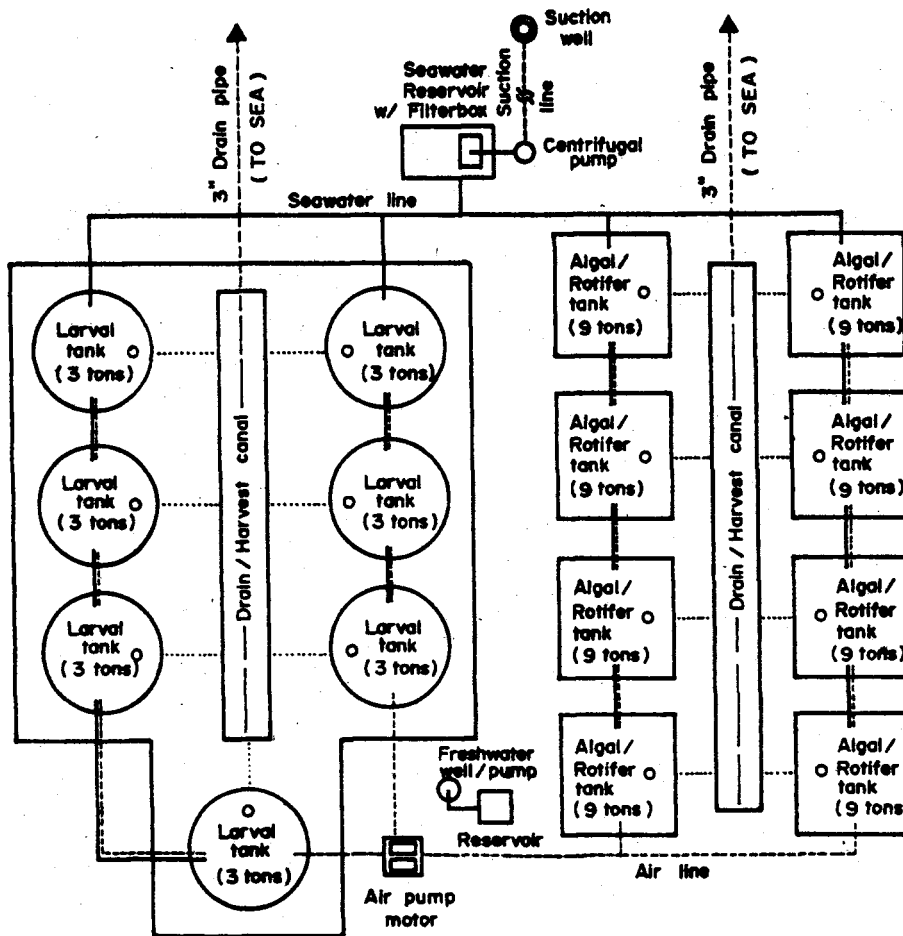

Fig. 1. Layout of a typical small-scale milkfish hatchery.

Brine Shrimp Hatching Tank. A cylindro-conical plexiglass, transparent conical fiberglass, or plastic carbuoy may be used in hatching *Artemia* cysts. The capacity of the hatching container varies depending on the amount of *Artemia* to be hatched.

Seawater Storage Tank A seawater tank with a capacity of at least 50% of the total volume of culture tanks is recommended. Storage tank should be elevated so that filtered seawater can be distributed to all tanks by gravity flow (Fig. 2).

A milkfish hatchery should have the following equipment:

Seawater centrifugal pump (2 HP) for pumping prefiltered seawater from the suction well to filter tank and reservoir.

Air blower (1.5 HP) provides aeration to all tanks.

Submersible pump (1/3 HP) for mass transfer of algae to rotifer tanks.

Freshwater pump (1/3 HP) draws freshwater from a shallow well for hatchery use.

Standby generator (5 KVA) should be available in case of power failure.

Stereomicroscope for estimating density of rotifer, egg, and larval samples.

Weighing scales : (i) 1-kilogram capacity for weighing *Artemia* cysts and (ii) 10-kilogram capacity for weighing fertilizers.

Spare pumps should be provided in case of breakdown.

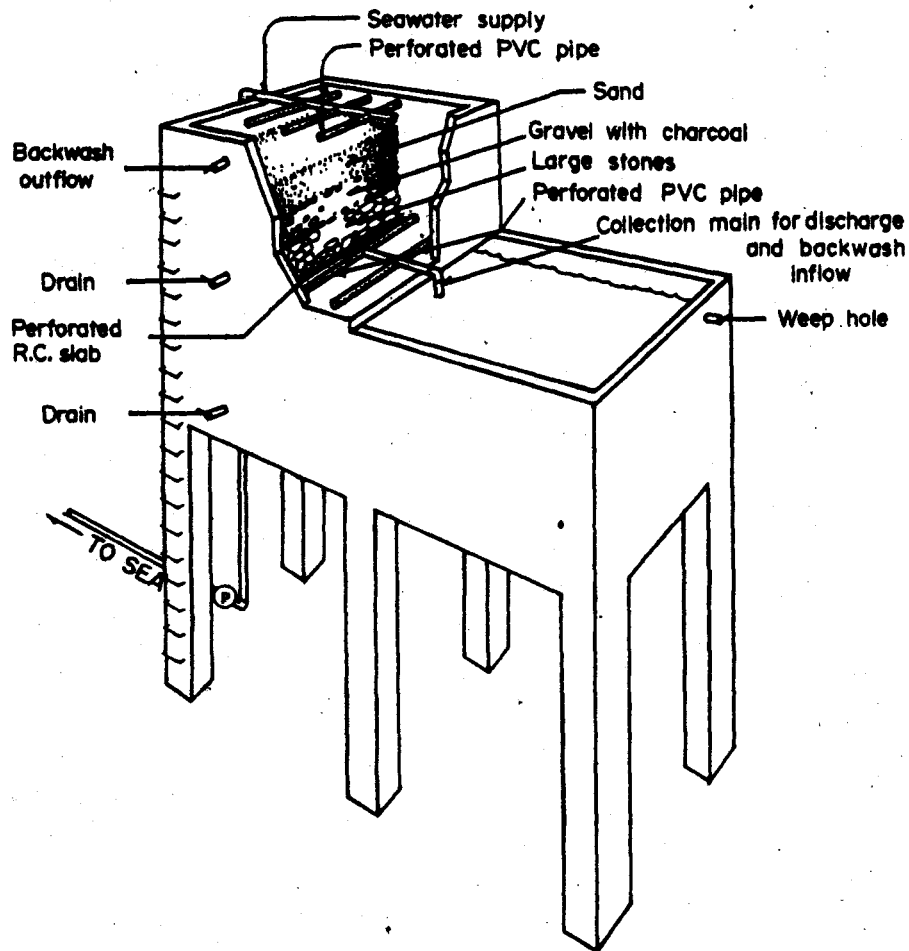

Fig. 2. Elevated seawater reservoir with cut-out diagram of its sand filter.

Item Two: Packing and Transporting Milkfish Eggs

Eggs should be handled carefully and transferred as soon as possible to the hatching tanks. When transport to the hatchery site takes more than one hour, it is advisable to pack and transport 6 hours after spawning, that is, when eggs are already at a more advanced stage of embryonic development. About one hour before transport, eggs are packed following these steps:

- 1) Turn off aeration and gently swirl the water once or twice in order to concentrate dead eggs to the bottom of the container. Quickly siphon out these dead eggs by using a rubber or plastic tubing.

- 2) Slowly drain to one-half the volume of water suspending the collected eggs. This is done by siphoning out the water with the nozzle of the tube wrapped with screen net or filter so that live eggs are excluded.

- 3) Layer *pandan* bags (*bayong*) with 2-3 inches of rice hull, 2 liters of crushed ice, and another layer of rice hull in that order (Fig. 3).

- 4) Into each prepared *bayong*, set a double-layered plastic bag containing 15 liters of seawater with a salinity of 20-35 ppt. Note that milkfish eggs tend to sink in seawater with salinities of 25 ppt or less; these eggs are not dead and will float when transferred to higher salinities.

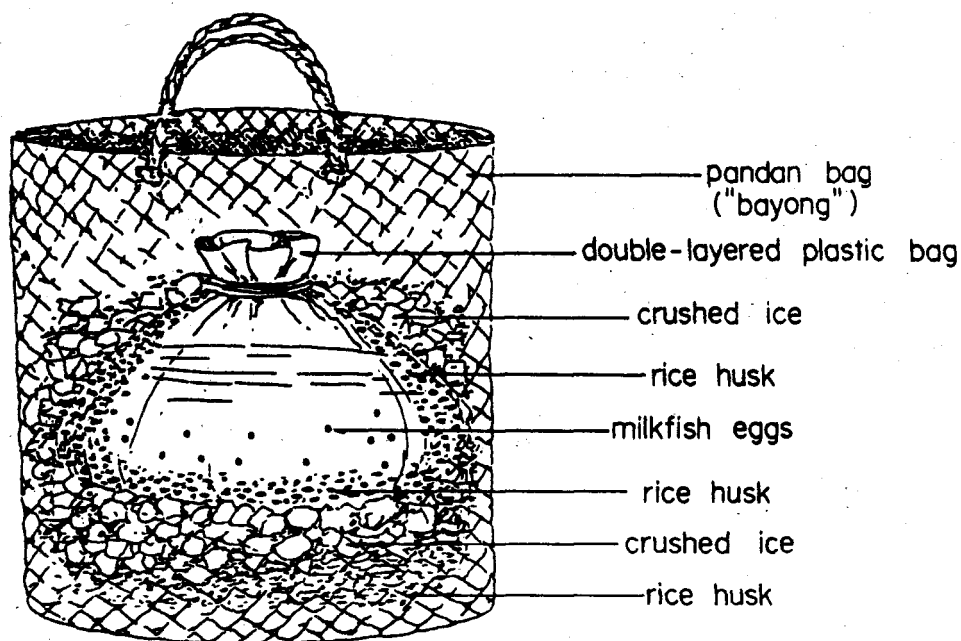

Fig. 3. *Bayong* bag for transporting milkfish eggs.

- 5) Using a fine scoop net (pore size, 0.6-0.8 millimeter), gently concentrate a scoopful of eggs.
- 6) Gently scoop out with a beaker 150 milliliters of eggs from the net and quickly transfer into the bag of water in the *bayong*. About 100 milliliters has approximately 60,000 eggs. Never place more than 150 milliliters of eggs into each bag of 15 liters seawater in the *bayong*.
- 7) Fill to inflate each plastic bag with oxygen and seal tightly with rubber bands.
- 8) Place half a liter of crushed ice and some rice hull on top of each plastic bag of eggs.
- 9) *Bayong* bags must be kept under shade during transport, but make sure water temperature in the bags does not go down to 20°C or lower throughout the trip. The ideal water temperature in the *bayong* is 28°C for at least 2 hours.

Item Three: Preparing Hatching and Larval Rearing Tanks

Hatching occurs in 14 to 16 hours after collection. Hatchery and larval rearing tanks therefore have to be prepared at least one day before eggs are obtained.

Preparation of Hatching and Larval Rearing Tanks. (1) Thoroughly scrub with scrubbing pad or nylon brush and detergent the 500-liter fiberglass hatching tanks and 3-ton larval rearing tanks. Rinse well with seawater or freshwater. (2) Fill up the tanks, preferably with freshwater, and disinfect by chlorination

Chlorination Procedure for Disinfection:

(1) Determine capacity (water volume) of tank to be disinfected. (2) To obtain a 200 ppm solution, calculate the amount of chlorine powder or granules to be used from the following information:

- 1 gram/1000 liters of water = 1 ppm
- 1 milligram/liter of water = 1 ppm

Example:

For a 3.0-ton (3000-liter) capacity tank, determine the amount of chlorine granules to obtain

a 200 ppm solution.

If 1 gram/1000 liters = 1 ppm, then 200 gram/1000 liters
= 200 ppm

Therefore:

$$\frac{200 \text{ grams}}{x} = \frac{1000 \text{ liters}}{3000 \text{ liters}}$$

x = 600 grams of chlorine granules to be dissolved
in 3000 liters of water to make 200 ppm solution

(3) After computing for the amount of chlorine granules needed, weigh out the desired amount. Dissolve this in a small amount of freshwater before adding to the tank to be disinfected. Mix well. (4) Let stand overnight. Drain water the following day. Clean the tank by scrubbing with sponge and detergent. Rinse thoroughly and let dry.

Item Four: Hatching Milkfish Eggs

Procedures for hatching milkfish eggs are as follows:

- 1) Fill up hatching tank with filtered seawater. To estimate the number of hatching tanks needed, allow a density of 300 eggs/liter for optimum hatching. Eggs are packed in double-layered oxygenated plastic bags usually at a density of 8,000 eggs/liter of transport water.
- 2) Upon arrival of eggs at the hatchery, let the plastic bag float in the hatching tank for 15 minutes to allow temperature in the bag to equilibrate with the temperature in the hatching tank. Allow small amounts of water in the hatching tank to intermix slowly with water in the transport bag before gently pouring the content of the bag into the hatching tank.
- 3) Stock not more than 300 eggs/liter. Aerate moderately to prevent aggregation of eggs.
- 4) Wait for about 15-30 minutes, then stop aeration. Gently swirl the water and wait until water motion stops. Siphon out unfertilized and dead eggs at the bottom of the tank.
- 5) Flow-through filtered seawater into the hatching tank for 1-2 hours.
- 6) Milkfish eggs at 28-29°C usually hatch within 24-26 hours after spawning or 14-16 hours after collection. When hatching is completed, siphon out egg cases, dead eggs and other debris.

Item Five: Food Organisms for Milkfish Larvae

The food organisms used for rearing milkfish larvae are the unicellular green alga *Chlorella*, the rotifer *Brachionus*, and the brine shrimp *Artemia*. Green algae aid in maintaining good water quality in the larval rearing tank and serve as food for *Brachionus*. Milkfish larvae are fed with rotifers throughout the whole rearing period. Brine shrimp nauplii are fed on the 15th day to the 21st day when larvae are usually harvested.

Mass culture of food organisms has to be started at least one month before larval rearing commences. Small-scale indoor culture of these food organisms in fiberglass tanks precedes large-scale culture in canvas or concrete tanks.

The procedure for culturing starters of *Chlorella* and *Brachionus* in indoor facilities and then in outdoor tanks follows. Figure 4 illustrates programming of both culture operations.

Chlorella and *Brachionus* starters may be obtained from research institutions or from other hatcheries. *Artemia* cysts, on the other hand, are available from aquaculture supply stores. Quality *Artemia* strains with high hatching efficiency are preferred.

Item Six: Larval Rearing

Water management and feeding (Fig. 5) during the larval stage are as follows:

- 1) Maintain mild aeration during the first week of rearing. Should water in rearing tanks turns

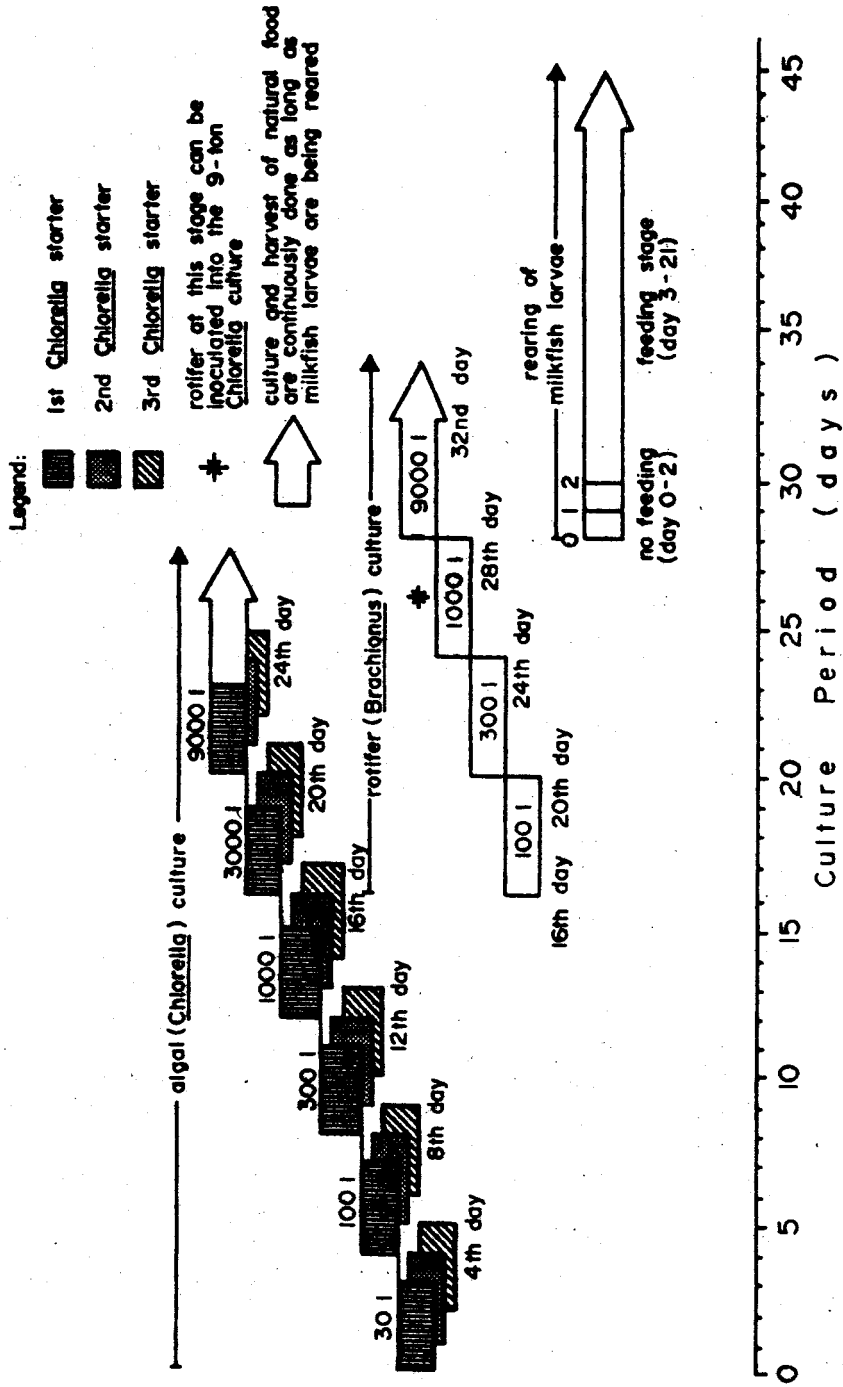

Fig. 4. Programming of natural food culture for milkfish hatchery operations.

pale, add enough *Chlorella* to restore the green-to-light-green color. *Chlorella* should be added preferably in the morning before feeding the larvae.

2) Starting on day 2 until day 14, add *Brachionus* at 10-15 individuals/milliliter.

3) *Artemia* nauplii at 0.5 individual/milliliter are fed from day 15 to day 17. Increase feeding level to 1 individual/milliliter from day 18 until harvest (day 21).

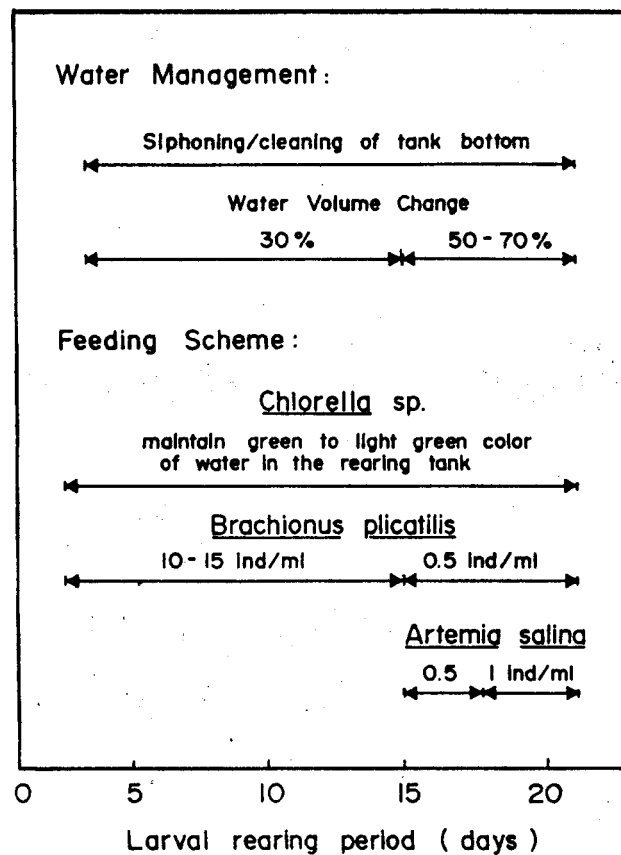

Fig. 5. Water management and feeding scheme for rearing milkfish larvae.

4) Siphon out wastes and uneaten food in the tank bottom every morning from day 2 until day 21

5) Change 30% of the water volume every morning from day 2 until day 14. Change 50-70% of the water from day 15 to day 21.

Item Seven: Harvesting Milkfish Larvae

Milkfish larvae on day 21 are at about the same developmental stage as wild-caught fry and are ready to be harvested. The procedures for harvesting, estimating and packing larvae to be sold or transported for stocking in nursery ponds or tanks follow those practiced by prawn hatchery operators and fry gatherers and dealers.

1) Drain water in the rearing tank to about one foot deep.

- 2) Using a small basin, scoop larvae and transfer into a big plastic basin.
- 3) To estimate the number of harvestable larvae, count the larvae in a basin of known water volume. This serves as a standard on which all estimates are based. Distribute larvae evenly in other basins containing the same volume of seawater as the standard basin. Compare visually whether the other basins contain more or less the same number of larvae as for the standard basin.
- 4) Pack larvae in double-layered oxygenated plastic bags containing 8-15 liters of seawater at a loading rate of 300 larvae/liter.

Source: **Milkfish Hatchery Operations** by R.S.J. Gapasin and C.L. Marte. Aquaculture Extension Manual No. 17, SEAFDEC Aquaculture Department, Tigbauan, Iloilo, Philippines, May 1990.

ECONOMICALLY IMPORTANT SEaweEDS OF PANAY ISLAND

Scientific name	Local name	Uses
<i>Acanthophora spicifera</i>		Human food, growth regulator
<i>Chondria armata</i>		Medicine (vermifuge and antibacterial)
<i>Euचेuma arnoldii</i>	guso	Source of carrageenan
<i>E. cottonii</i>	guso	Human food, source of carrageenan
<i>E. denticulatum</i>	guso	Human food, source of carrageenan
<i>E. striatum</i>	guso	Human food, source of carrageenan
<i>Galaxaura oblongata</i>		Source of sulfated sugar
<i>Gelidiella acerosa</i>		Human food, source of agar
<i>Gelidiopsis intricata</i>		Human food
<i>Gracilaria arcuata</i>	gulaman	Human food, source of carrageenan
<i>G. blodgettii</i>	gulaman	Human food, source of agar
<i>G. coronopifolia</i>	gulaman	Human food, source of carrageenan
<i>G. euचेumoides</i>	cawat-cawat	Human food, source of carrageenan
<i>G. salicornia</i>	lagot	Human food, source of carrageenan
<i>Gracilaria</i> sp.	gulaman	Human food, source of agar
<i>Halymenia durvillaei</i>		Human food, source of carrageenan
<i>Hypnea cervicornis</i>	sumon-sumon	Human food, source of carrageenan
<i>H. esperi</i>		Human food, source of carrageenan
<i>H. pannosa</i>		Human food, source of carrageenan
<i>H. valentiae</i>		Human food, source of carrageenan
<i>Laurencia cartilaginea</i>	lagot-laki	
<i>L. flexilis</i>		Source of agar
<i>L. obtusa</i>		Human food, medicine (vermifuge and antibacterial), source of amino acids
<i>L. papillosa</i>		Human food, medicine (vermifuge and antibacterial), source of agar
<i>Scinaia moniliformis</i>		Human food

Source: List of Panay Seaweeds, Seaweeds Project. SEAFDEC Aquaculture Department, Tigbauan, Iloilo, Philippines.

REDUCING AQUACULTURE FEED COSTS IN THE TROPICS

In aquaculture, feed is often the largest operating cost item. As culture intensifies, or relies more and more on external inputs, feeding costs go up because of the large percentage of animal protein that must be added to the diets.

Fish culture in the tropics is mostly extensive, that is, no feed, nor fertilizer inputs, and semi-intensive which uses some feed or fertilizer inputs. Conflicting demands for space and water resources have led to an increasing trend toward intensification. As aquaculture relies more and more on feed and fertilizer inputs, research is needed to develop low-cost feeds.

While most studies explore the use of readily available agricultural by-products, two unusual, but promising, methods to reduce feed costs in semi-intensive aquaculture systems have received little attention. Dr. Sena S. de Silva, in a press release of ICLARM (the International Center for Living Aquatic Resources Management) describes both methods. One involves the use of less protein in practical diets; the other uses different feeding strategies.

Economical dietary protein level.

De Silva explains that the optimal dietary protein level is that which gives the fastest growth. Among fish, this level varies, depending on such factors as age, size and environmental conditions. From a commercial point of view, however, the best dietary protein level is that which gives the highest economic return.

Studies reveal that the level which generates the most profit may be lower than the level which produces fastest growth. Tests on four tilapia species show that the best protein level, in terms of economics, is around 25% compared to 34% for the protein level giving fastest growth. The result is a 10% saving on feed costs although it involves a slightly longer grow-out time.

This shows that, especially in developing countries where labor costs are comparatively low, farmers can save on costs by feeding diets with a protein content lower than optimal for growth, without significant loss in growth or yield.

Mixed feeding.

In the tropics, direct and indirect natural 'feed inputs' from the environment can also be considerable, making it possible to further lower the dietary protein content for most cultured species.

The use of mixed feeding schedules is another method with many possibilities for reducing feed costs without lowering growth and yield. In experiments with tilapia and carp, alternating a high protein diet with a low protein diet produced growth rates comparable to those for fish continuously fed a high protein diet. This strategy represents a challenging area for simple, but useful, research in aquaculture in the tropics.

The concepts presented here may well provoke 'traditional fish nutritionists.' But De Silva asserts that, "in tropical aquaculture, which is mostly extensive to semi-intensive, formulation of the 'balanced diet' is not the priority; it is exploring means to reduce operating costs and making equally effective diets which are well within the economic reach of the small-scale farmer. This is not to say that in the tropics, fish do not require balanced diets. What is often forgotten is that in tropical systems, fish have access to nutrients from natural sources."

Source: ICLARM Press Release, April 1990.

13 GRADUATE FROM AQUAMANAGEMENT

Thirteen participants from Malaysia, Thailand, Sri Lanka, and the Philippines graduated from SEAFDEC/AQD's first *International Training Course In Aquamanagement*, May 18, at the Tigbauan Main Station.

The graduates were: Henry O. Luhat and Abdul Rahman bin Kassim - Malaysia; Weerapong Mekmallika and Maneerat Tangkhum - Thailand; Dinesh de Silva - Sri Lanka; Maura G. Ocampo, Kiese T. Usman, Adan S. Diamante, Nenita C. Alura, Prescilla V. Leviste, Ariel L. Verino, Mario S. Bechayda, and Leonora A. Tuazon - Philippines. Nine of the participants (two from Malaysia, two from Thailand, and five from the Philippines) were supported by the SEAFDEC Fellowship Fund contributed by the Government of Japan.

The four-week course was aimed at developing the skills of project managers in aquaculture planning and implementation, monitoring and evaluation. The course also covered topics on managerial tools and new developments in aquaculture.

The training course which opened April 18 was the second course offered by AQD this year. The first was the ***Fish Health Management Training Course***. Other training courses for 1990 are: ***Hatchery/Nursery of Marine Finfishes***, June 13-August 1; ***Prawn Hatchery & Nursery Operations***, August 29-October 18; and ***Fish Nutrition***, October 3-November 13. Applicants may contact: **Training and Information Division, SEAFDEC Aquaculture Department, P.O. Box 256, Iloilo City, Philippines; Telex 29078 SEAFDC PH; Iloilo Fax: 63-33-76642.**

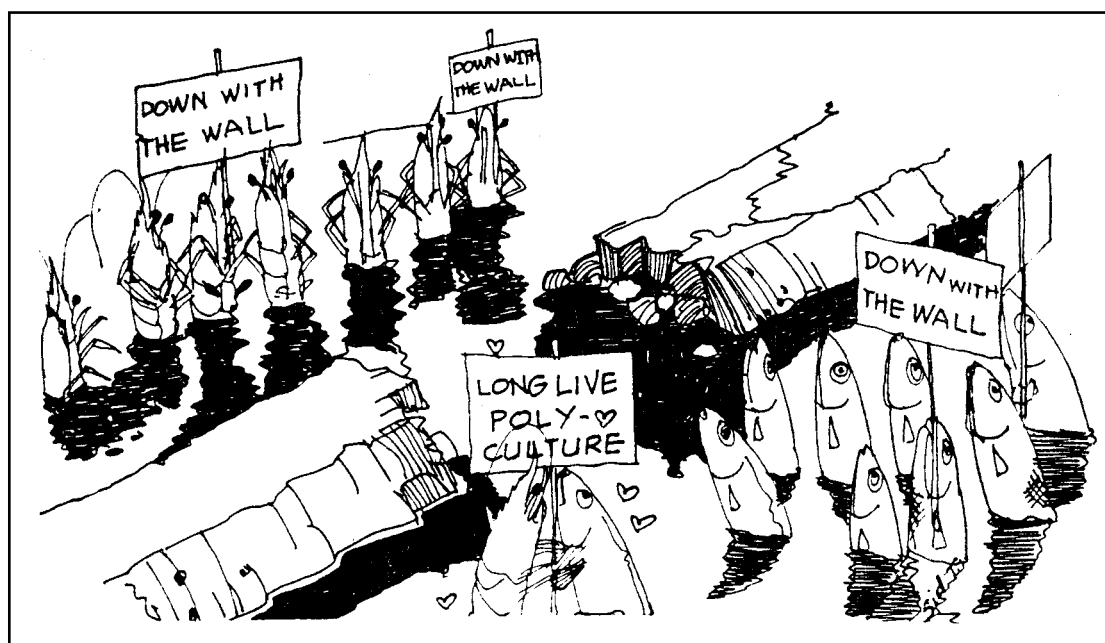

AQUA FARM NEWS is produced bimonthly by the Audiovisual-Print Section, Training & Information Division of the Aquaculture Department, Southeast Asian Fisheries Development Center, P.O. Box 256, Iloilo City, Philippines.

